

# CHAMPION

Hoist and Equipment

Dunn, North Carolina, U.S.A.

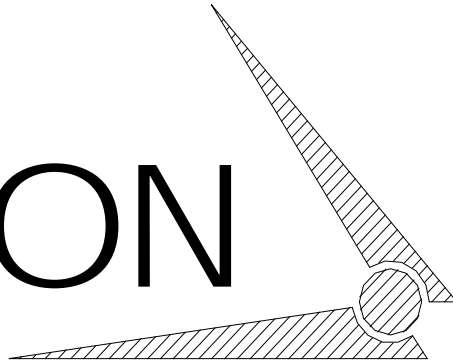

AN AFFILIATE OF

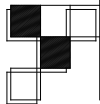
The **Godwin**  
 **Group**

200 CHAMPION DRIVE  
DUNN, N.C. 28334  
(910) 897-4995 FAX: (910) 897-7306

## TRADITIONAL CONVERSION HOIST

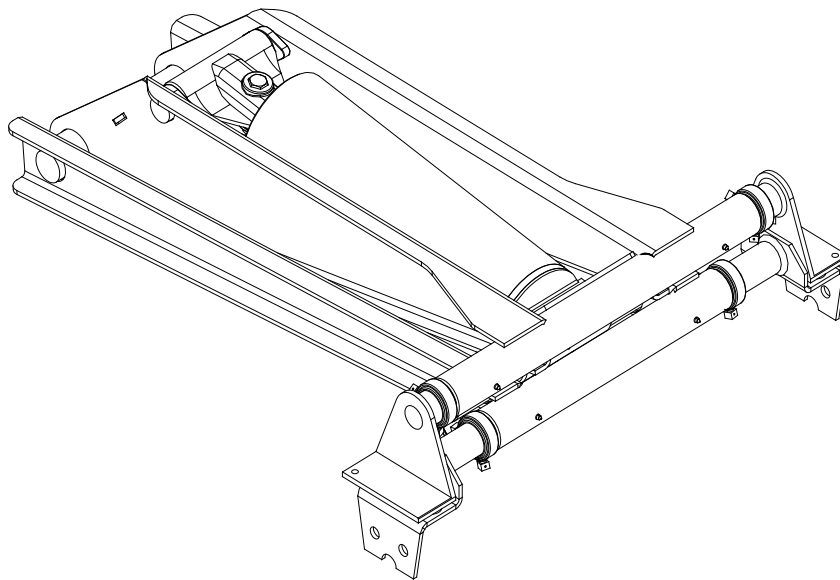

Operation & Installation Manual

## Notes

It is recommended that the Owner/Operator record the following information immediately after purchasing. So that when calling for Parts or Service, the information will be readily on hand.

### Dump Trailer Body

Model Number \_\_\_\_\_

Serial Number \_\_\_\_\_

### Subframe Assembly

Model Number \_\_\_\_\_

Serial Number \_\_\_\_\_

### Hoist Assembly

Model Number \_\_\_\_\_

Serial Number \_\_\_\_\_

### Truck

Year \_\_\_\_\_

Make \_\_\_\_\_

Model \_\_\_\_\_

Truck Number \_\_\_\_\_

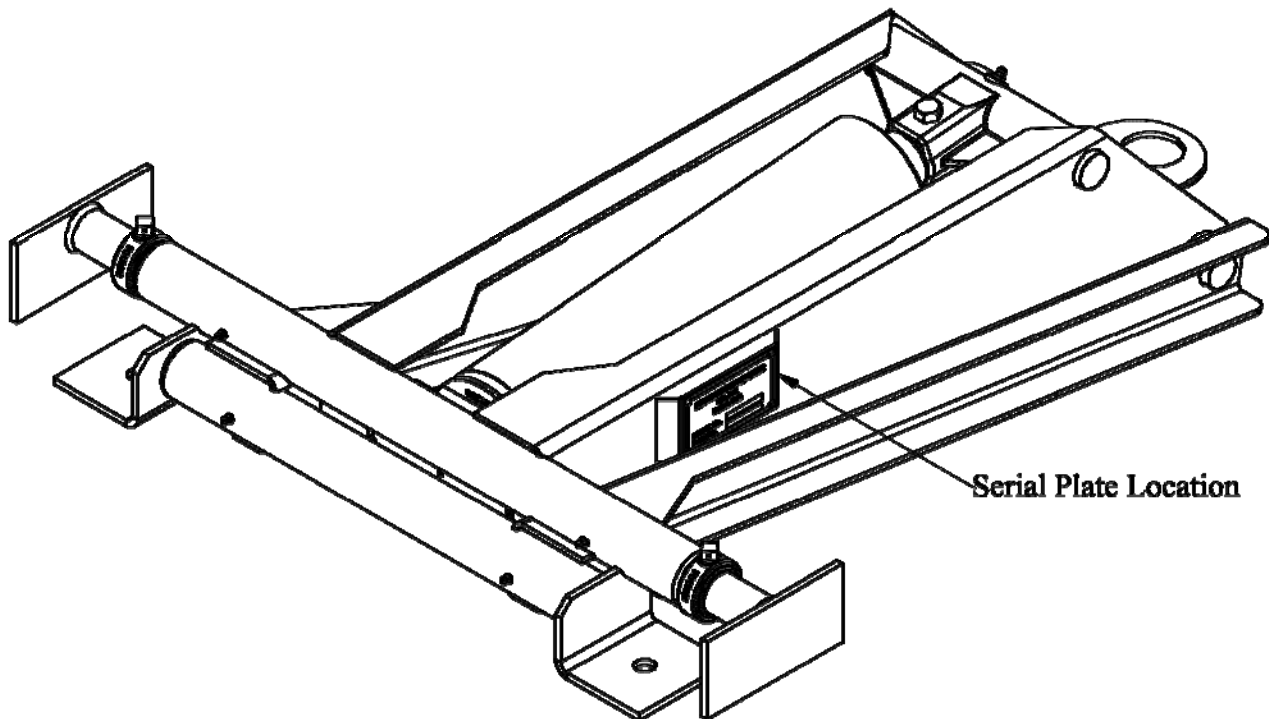

June/2017

# TABLE OF CONTENTS

	<b>Page</b>
Safety Alert Symbols .....	4
Safety Checklist .....	5
Periodic Inspections .....	6
Hydraulic Plumbing Diagram, Single Acting Electric Pump (PD40048) .....	7
Hydraulic Plumbing Diagram, Double Acting Electric Pump (PD40045) .....	8
Hydraulic Plumbing Diagram, Double Acting Electric Pump (PD40079) .....	9
Electric Pump Priming Procedure .....	10
Electric Pump Troubleshooting Procedure .....	11
Trailer Hoist Safety Prop and Hinge Hardware (K12424) .....	12
Safety Prop Installation .....	13-14
Hoist Location on Trailer & “G” Dimension Measurements .....	15
Removing Slack from Hoist & Rear Hinge .....	16
Hoist and Dump Body Installation Procedure for Trailers .....	17
CS412T Hoist Capacities, Dimensions, & Parts .....	18-20
CS412T Rear Hinge Assembly .....	21
CS415T Hoist Capacities, Dimensions, & Parts .....	22-24
CS515T Hoist Capacities, Dimensions, & Parts .....	25-27
CS615T Hoist Capacities, Dimensions, & Parts .....	28-30
CS415T/CS515T/CS615T Rear Hinge Assembly .....	31
CS520T Hoist Capacities, Dimensions, & Parts .....	32-34
CS620T Hoist Capacities, Dimensions, & Parts .....	35-37
CS520T/CS620T Rear Hinge Assembly .....	38
CS5520T Hoist Capacities, Dimensions, & Parts .....	39-41
CS6620T Hoist Capacities, Dimensions, & Parts .....	42-44
CS5520T/CS6620T Rear Hinge Assembly .....	45
CS628T Hoist Capacities, Dimensions, & Parts .....	46-48
CS628T Rear Hinge Assembly .....	49
Warranty .....	50

**Notice:** Before Operating, Maintaining, or Repairing the Hoist read this manual completely and refer to it continuously.

## Safety Alert Symbols

The terms Danger, Warning, and Caution are used to indicate different levels of potential hazard to equipment and personnel.

**⚠ DANGER** Indicates a hazardous situation which, if not avoided, will result in death or serious injury. This signal word is to be limited to the most extreme situations.

**⚠ WARNING** Indicates a hazardous situation which, if not avoided, could result in death or serious injury.

**⚠ CAUTION** Indicates a hazardous situation which, if not avoided, could result in minor injury.

**NOTICE** Used to warn of a potential hazard to the equipment.



Safety Decal Locations



## Safety Checklists



To prevent possible death or injury to personnel and damage to the equipment, the following checklist is to be performed prior to operating and while operating the Trailer and Hoist.

### Pre-Operation Checklist

- Prior to initial operation of Trailer and Hoist read this manual completely and refer to it continuously.
- Prior to operation of Hoist read and understand all the Safety Symbols, (Cautions, Warnings, and Dangers) in this manual, identify them on the Trailer and Hoist, and follow their instructions carefully. If any Safety Symbols are missing or incomplete on the Hoist order them from Godwin Manufacturing.
- Do not allow unauthorized personnel to operate this equipment.
- Do not allow personnel to ride in or on the trailer body.
- Do not operate a loaded trailer on unlevel or soft surfaces.
- Prior to operation of Hoist inspect to ensure that the safety props, pump/valve guard are in place and in good working order.

### Operational Checklist

- Before loading the Trailer make sure that the load does not exceed the Gross Vehicle Weight (GVW) rating of vehicle or the Hoist's rated lifting capacity.
- Always load the Dump Body evenly from side-to-side and from front-to-rear.
- Prior to operating the hoist ensure the area is clear of personnel and equipment.
- Do not allow hoist controls and the area around them to become cluttered with tools, cans, etc.
- Do not operate the hoist under Power Lines.
- Do not raise the hoist when trailer is in motion.
- Do not move the trailer with the hoist raised.
- Always release tailgate latching controls prior to lifting the dump body.
- Always operate the hoist controls from inside the truck cab.
- Do not go underneath a loaded and raised trailer body under ANY circumstances.

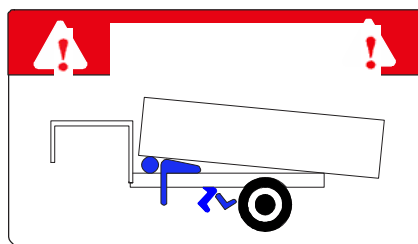

- Do not go underneath a truck with the engine running.
- Do not go underneath an unloaded raised trailer body unless the safety props are properly installed.
- Do not leave trailer unattended with trailer body raised.

### Post Operation Checklist

- Do not use hands or other body parts to check for hydraulic leaks.
- Follow all Federal, State, and local regulation pertaining to this equipment.
- Keep all equipment properly maintained and serviced.

## **Periodic Inspections**

The following checklist is to be followed prior to operating and while operating the Trailer and Hoist.

### **Daily Inspection (Before Operating)**

- Check hydraulic oil level and add more to the reservoir as needed.  
For PTO driven pumps use HD 32 hydraulic oil.  
For electric driven pumps use ATF, automatic transmission fluid.
- Check for any fluid leaks under truck and hoist.
- Make sure all components are securely fastened, such as frame/pump guard, tool box is closed, hydraulic hoses for spreader/plow properly stowed, etc.
- Check all lighting to be sure it is functioning properly.
- Check lighting on any towed equipment.
- Inspect hitch if towed equipment is attached and be sure safety chains are fastened.
- Test hydraulic functions and observe for proper operations.
- Check tire pressure per markings on the tires.

### **Weekly Inspection**

- Perform all of the above checks.
- Inspect all mechanical functions, i.e., hoist pivots, rear hinge pivots, single hitch, etc. Be sure they have been properly lubricated and show no signs of stress.
- Test Low Oil Shutdown system to be sure it is operating properly.

### **Bi-Monthly Inspection**

- Lubricate all hoist pivot points and rear hinge assemblies with chassis grease.
- Lubricate pintle hitch with chassis grease.
- 

### **Six Months to One Year (Depending upon usage)**

- Change hydraulic oil filter. (1st change after 50 hours of operation.)
- Inspect suction strainer in oil tank.
- Check hydraulic oil for contamination, discoloration, signs of wear, etc.

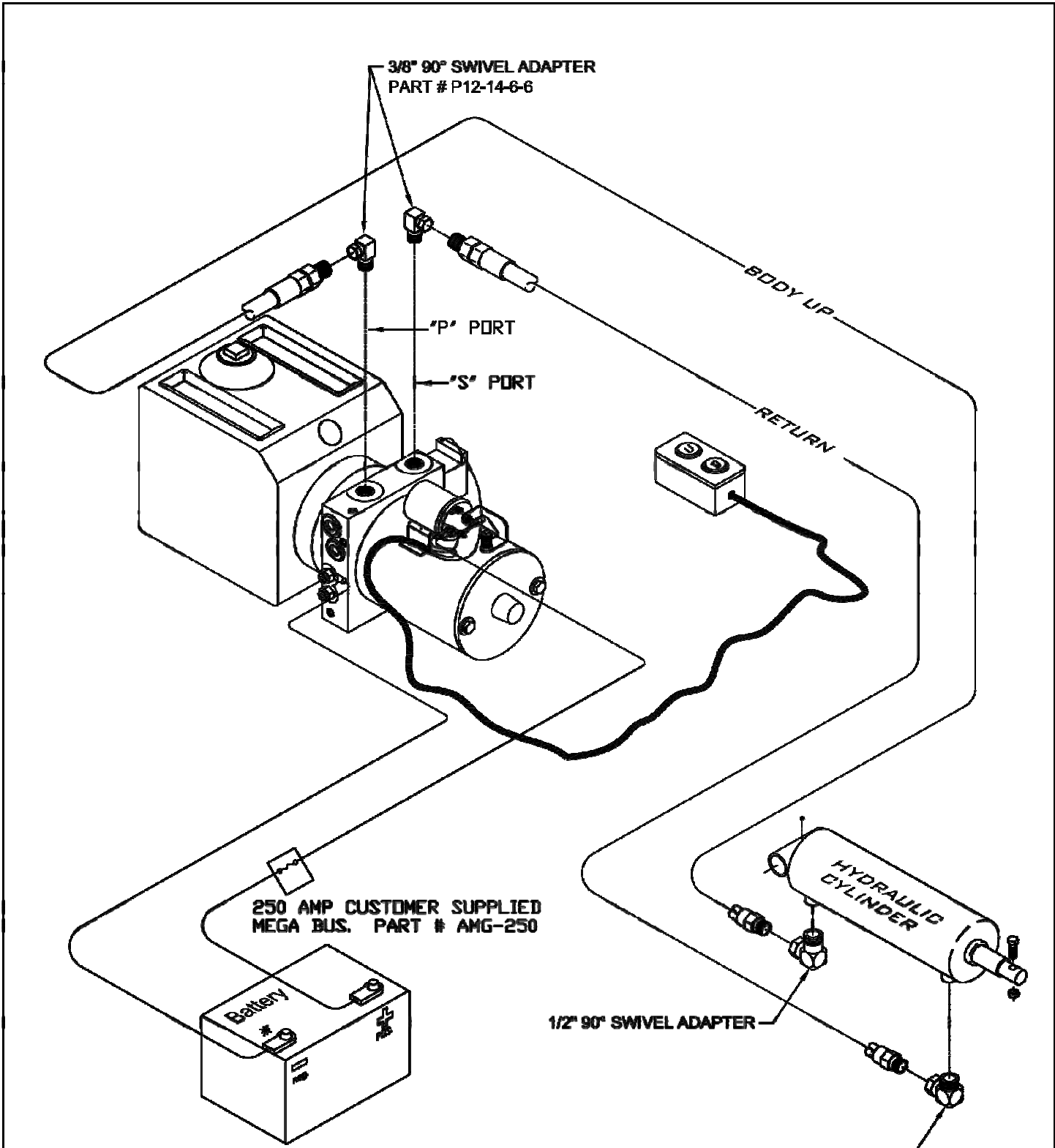

**NOTE: Ground Wire is to be ground to valve body.  
DO NOT GROUND TO CHASSIS!**

**NOTE:  
HYDRAULIC PORT FITTINGS ORIENTATION MAY  
VARY DEPENDING ON CHASSIS TYPE.**

<b>HYDRAULIC PLUMB DIAGRAM SINGLE ACTING ELECTRIC PUMP</b>	
GODWIN MFG. CO., INC. DUNN, NORTH CAROLINA	<b>PD40048</b>

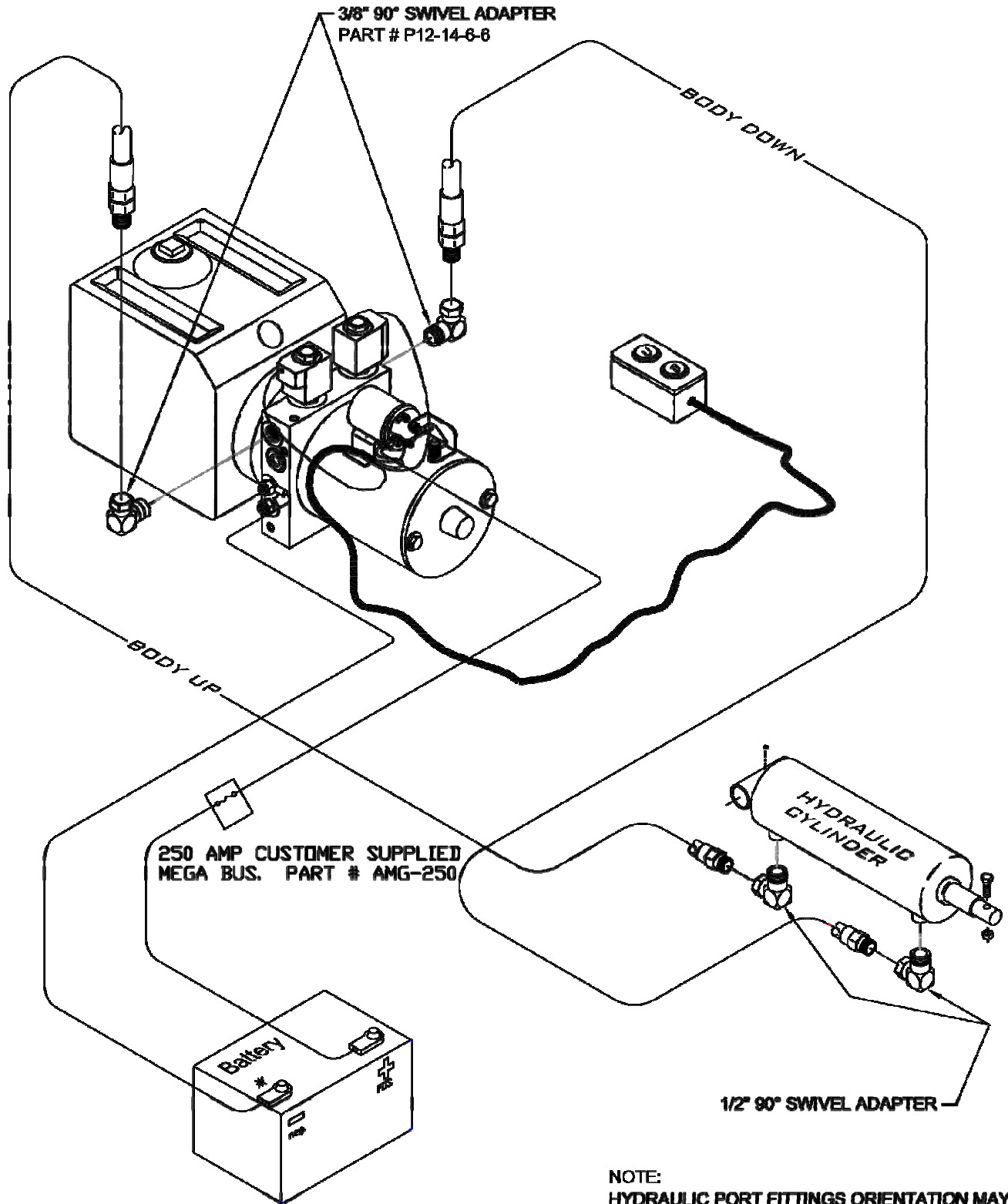

**NOTE: Ground Wire is to be ground to valve body.  
DO NOT GROUND TO CHASSIS!!**

**NOTE:  
HYDRAULIC PORT FITTINGS ORIENTATION MAY  
VARY DEPENDING ON CHASSIS TYPE.**

<b>HYDRAULIC PLUMB DIAGRAM DOUBLE ACTING ELECTRIC PUMP</b>	
<b>GODWIN MFG. CO., INC. DUNN, NORTH CAROLINA</b>	<b>PD40045</b>

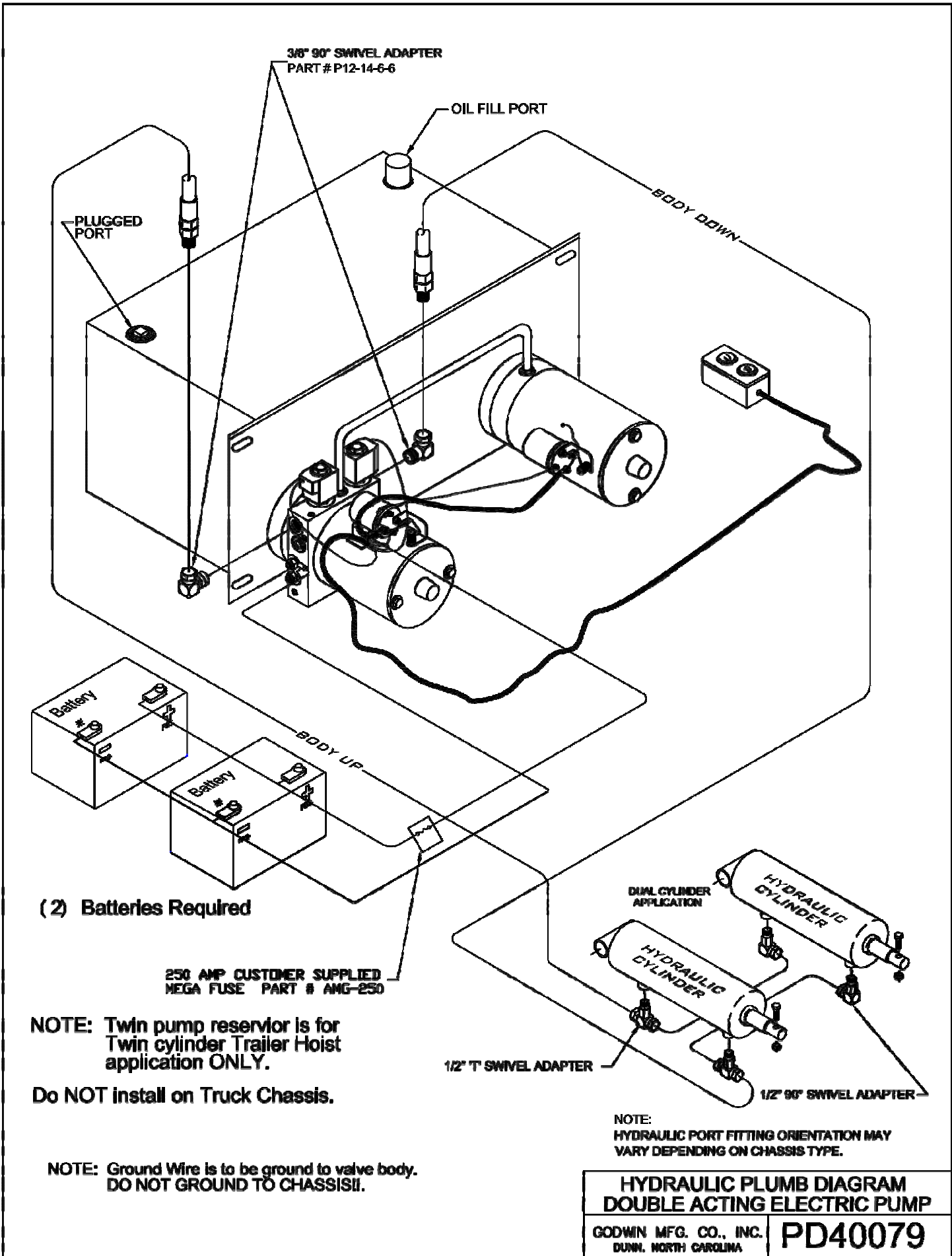

3/8" 90° SWIVEL ADAPTER  
PART #P12-14-6-6

OIL FILL PORT

PLUGGED PORT

BODY DOWN

BATTERY

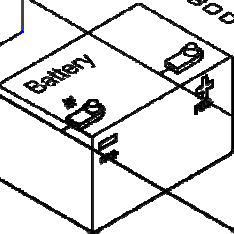

(2) Batteries Required

250 AMP CUSTOMER SUPPLIED  
MEGA FUSE PART # AMG-250

NOTE: Twin pump reservoir is for  
Twin cylinder Trailer Hoist  
application ONLY.

Do NOT install on Truck Chassis.

NOTE: Ground Wire is to be ground to valve body.  
DO NOT GROUND TO CHASSIS!!

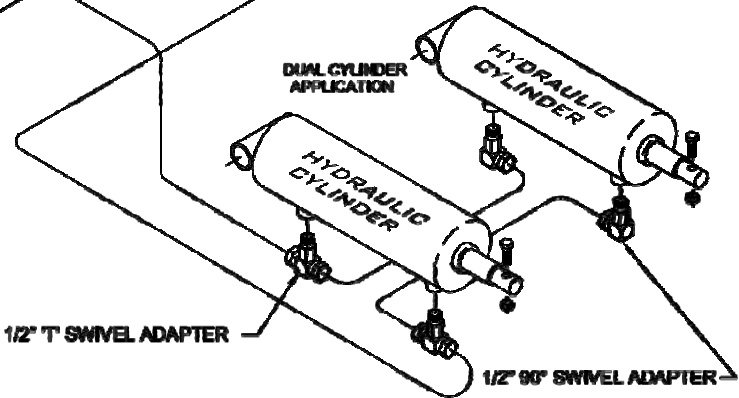

NOTE:  
HYDRAULIC PORT FITTING ORIENTATION MAY  
VARY DEPENDING ON CHASSIS TYPE.

**HYDRAULIC PLUMB DIAGRAM  
DOUBLE ACTING ELECTRIC PUMP**

GODWIN MFG. CO., INC.  
DUNN, NORTH CAROLINA

**PD40079**

## Electric Pump Priming Procedure

### Single acting (M-3519) or Double acting (M-3551)

A. Be sure hoist and electric pump are completely installed and ready to safely operate. Fill electric pump reservoir with Automatic Transmission Oil to within 1 inch of top.

B. Power the hoist “Up” using the “White” button the push button controller.

**NOTE:** If hoist does not start to raise within 10 seconds, stop and check that the hydraulic lines are correctly installed. See below:

Monarch 3551 (double acting, yellow) “C1” port = hoist raise (white button) = 3200psi.

“C2” port = hoist lower (black button) = 1200psi.

Monarch 3519 (Single acting, orange) “P” port = hoist raise (white button) = 3200psi.

“S” port = lower/vent to res (black button) = 0 psi.

### **NOTICE**

**To prevent damage to the equipment, Do Not allow the hydraulic reservoir to run out of hydraulic, Automatic Transmission Oil. Always maintain at least a half tank of oil.**

C. When powering the hoist ‘Up’ the first time it is imperative that the reservoir NOT run out of oil . Maintain a half tank of oil on the first lift by stopping and filling as needed.

D. Check for leaks during lifting operations and check for obstructions.

E. **For Double Acting Pump Only - Lower** the hoist by pressing the **black** button.

**NOTE:** Lower the hoist 1/3 and stop for 20 seconds, repeat two more times until hoist is fully lowered. Once the hoist has fully lowered CONTINUE to hold the “black” button until the oil in the reservoir stops moving (turbulence), about 20 seconds. The turbulence in the reservoir during this crucial step is filling the top side (or down side) of the cylinder. This typically has to be done only upon the initial installation or when the unit has run low in oil and is being refilled.

F. After steps A through E have been done fill the reservoir as needed to maintain  $\frac{2}{3}$  to  $\frac{3}{4}$  full with the bed down.

#### Helpful Hints:

1. Perform the above priming steps no more than twice in 30 minutes due to oil aerating.

2. If the reservoir overflows when lowering, the following could cause overflowing.

(a) Aerated oil

(b) “Hoist lower” line too small or obstructed

(c) Wrong ports used on pump

(d) extremely cold conditions.

3. Make sure the customer understands that the electric power unit (used when necessary) has the same lifting capacity but will be slower than a PTO driven unit.

4. Do not operate pump more than (2) minutes at a time or without truck engine running so as to keep a charge in battery.

### Electric Pump Priming Procedure

CHAMPION  
Holland Equipment  
Dunn, North Carolina, U.S.A.  
910-897-4995  
Fax 910-897-8822

**MP50398**

## Electric Pump Troubleshooting Procedure

### Single acting (M-3519) or Double acting (M-3551)

#### Electric pump Solenoid does not click

A. Bad hot (+) or ground (-) cables(s) from battery to pump. Be sure to use both cables and connect directly to the battery. Install a 250 amp Mega fuse at the positive battery connection.

**NOTE:** On newer trucks the ground cable from battery to chassis is too small to carry the load of the electric pump unit. Two individual positive and ground cables from battery to electric pump unit are needed to correct for the higher current draw.

B. Check for 12 volt signal at small post of solenoid when pressing the “Up” button on the control. If voltage is below 12 volts it may be an alternator or battery issue. If no voltage, it may be the switch or a broken or corroded wire.

#### Electric pump Solenoid clicks but motor does not operate.

A. Check battery connection between solenoid and motor.

B. Contacts in solenoid could be burned. (Check this by shorting the two large posts on the solenoid, if motor turns replace solenoid assembly.)

C. Bad motor.

D. Seized pump.

#### Motor/pump turns but hoist will not work.

A. Check for 12 volts at valve coil(s). Could be bad switch or broken wire.

B. Is/are coils magnetized when button is pressed? Could be bad coil or connector.

C. Cartridge stem could be bent. Lower bed completely, remove cartridge and roll it on a table to check for alignment.

D. Check pump unit pressure. Up should be 3200psi and Down (on double acting units) should be 800psi.

#### Hoist stuck in Up position, will not come down.

A. Check for 12 volts at “Down” coil.

B. Check for bent stem on “Down” cartridge. Call for service technician. **DO NOT ATTEMPT TO REPAIR!**



**A Hoist that is stuck in the Up position is an extremely dangerous situation and must be handled with great care. DO NOT ATTEMPT TO REPAIR! Call for a Service Technician.**

### Electric Pump Priming Troubleshooting

CHAMPION  
Hoist and Equipment  
Dunsmuir, California, U.S.A.  
916-897-4444  
916-897-4822

**MP50399**

# Trailer Hoist Safety Prop and Hinge Hardware

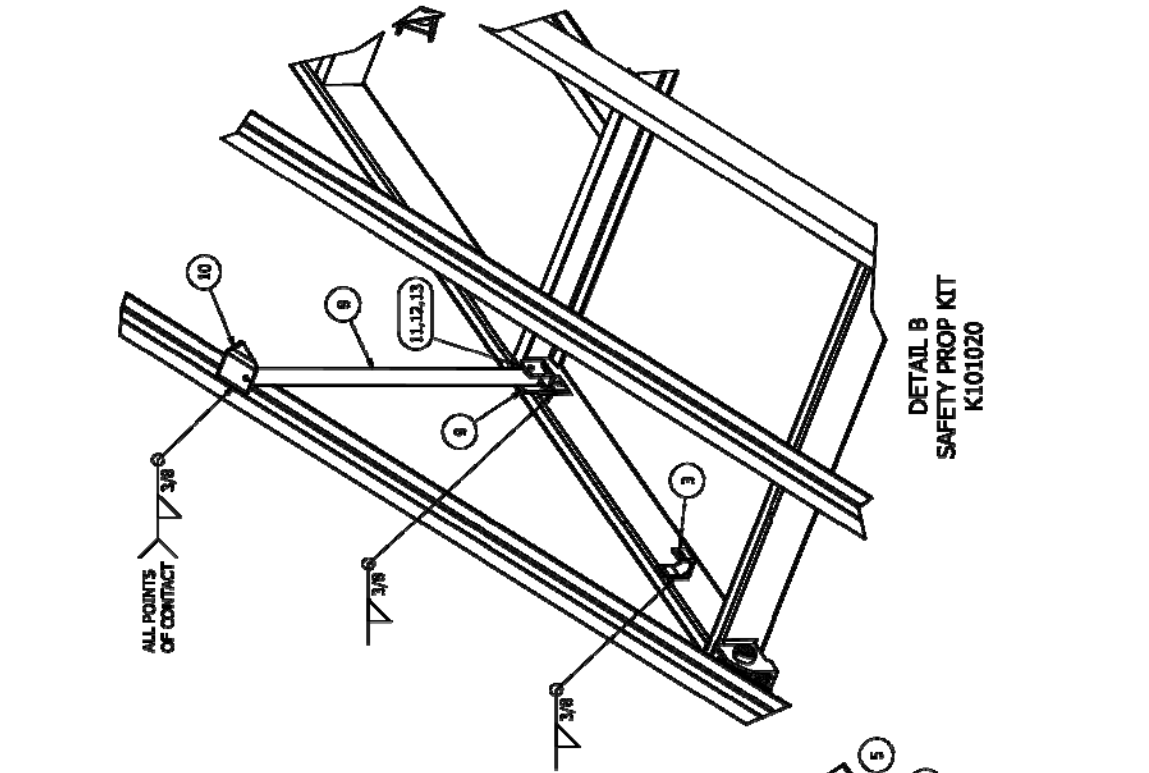

ITEM	QTY	PART NUMBER	DESCRIPTION
1	2	PCI0636	HINGE - FLIPPER 1 3/4"
2	2	PCI0583	1-3/4" REAR HINGE SUPPORT
3	1	PCI0468	SAFETY PROP BRACKET
4	2	PCI0816	Ø1. 3/4 REAR HINGE PIN, SHORT VERSION
5	2	102-219-A1	HEX BOLT, 3/8" x 3"
6	2	116-3-A1	Hex Nut, 3/8 UNC
7	2	116-3-A1	Lock Washer, 3/8
8	1	SM13033	STAND, SAFETY - 716/816
9	1	PCI1006	SAFETY STAND PIVOT BRACKET
10	1	PCI0415	CLIP SAFETY PROP CASTING
11	1	102-417-A1	1/2" HEX BOLT
12	1	118-5-A1	1/2" LOCK WASHER
13	1	116-5-A1	1/2" HEX NUT



## Safety Prop Installation

Federal Regulation 1926.601, paragraph 10, requires the use of a Safety Prop (Safety Strut or Body Prop) on Dump Trucks and Dumping Trailers.



- **Do not place any personal body parts between the trailer chassis and the moving parts of the Hoist and Dump Body.**
- **Do not use the Safety Prop when the Dump Body is loaded.**
- **Do not use damaged, bent, or loose Safety Props. Replace if damaged or bent and tighten all loose bolts.**
- **Read and understand the Safety Labels accompanying the Safety Prop. If label is damaged or missing, replace with a new label.**

## Safety Prop Information

1. Safety Prop is **not** designed to be used when the Dump Body is loaded. It is designed to be used only when the body is empty and needs cleaning, inspecting, or maintenance.
2. Godwin hoists are equipped with a single Safety Prop for Dump Bodies below 13 feet in length, and two Safety Props for Dump Bodies above 13 feet in length.
3. To prevent damage to Safety Prop and other equipment, keep Safety Prop stowed in Prop mounting bracket when not in use.

## Using the Safety Prop

1. Use the Hoist Controls to raise the Dump Body high enough to stand the Safety Prop up.
2. Align the Safety Prop with the Safety Cup and slowly lower the Dump Body down onto the Safety Prop.
3. When the Safety Prop is no longer required. Use the Hoist Controls to raise the Dump Body high enough to clear the Safety Prop and lower the Safety Prop down into a safe position.

## Safety Prop & Cup Installation

**Note:** The following instructions are for single Safety Prop trailers. Extra care must be taken when locating dual Safety Props to prevent drilling into a hydraulic hose or an electrical wire.

1. Use the Hoist to raise the Dump Body high enough to allow for measurement of correct alignment of Safety Prop & Cup. Leave body raised until installation is complete.

**Note:** The Safety Prop Cup must be located on a Dump Body cross channel. This means that the cup will be tucked-up inside of the dump body so that it can be welded to the cross channel, and the floor of the body.

**Note:** When correctly installed the Safety Prop will angle slightly (80°) towards the rear of the trailer. Put another way, 90° is perpendicular (vertical) to the trailer frame therefore 80° is 10° off of vertical. This will prevent the Safety Prop from slipping out of the Safety Cup.

2. Assemble the Safety Prop and Pivot Bracket by inserting a ½ inch bolt through the bracket and the prop. Secure it lightly with a nut.
3. Align the Pivot Bracket even with the top of the trailer chassis and tip the Safety Prop 80° towards the rear of the trailer. Slide the bracket and prop assembly along the chassis until the location of the Safety Cup is determined.

**Prior to locating the Safety Cup & Prop carefully inspect the area for any wiring or hydraulic hoses.**

**NOTICE** Pay particular attention to the inside of the chassis where the two holes for the Pivot Bracket will be drilled. It may be necessary to temporarily move any wiring or hoses out of the way when drilling the two holes.

## **Safety Prop Instructions (continued)**

### **Safety Prop & Cup Installation (continued)**

4. Mount the Safety Cup to the cross member, and underside of the floor. Secure it with a C-Clamp and weld all contact points with 3/8 inch bead.
5. Place the end of the Safety Prop in the newly mounted Safety Cup (at the 80° angle) and mark the location for the holes to be drilled into the truck chassis.
6. Disassemble the Safety Prop and Pivot Bracket by removing the ½ inch bolt holding the bracket and the prop together.
7. Align the Pivot Bracket to the mark on the chassis and remark the holes.
8. Remove the Pivot Bracket and drill the two holes. (Refer to Notice above.)
9. Mount the Pivot Bracket to the chassis with the lower bolt and assemble the Safety Prop to the Pivot Bracket and chassis using the longer bolt.
10. Tighten the lower (shorter) bolt firmly to the chassis and tighten the upper (longer) bolt enough to allow the Safety Prop to move back and forth, with effort.
11. Align the Safety Prop with the Safety Cup and rest the body on the Safety Prop and test for stability. (The Safety Prop should not move and should stay in the Safety Cup.)
12. Lift body off of Safety Prop and check tightness of bolts.
13. Lower Safety Prop forward alongside the chassis and lower body fully.

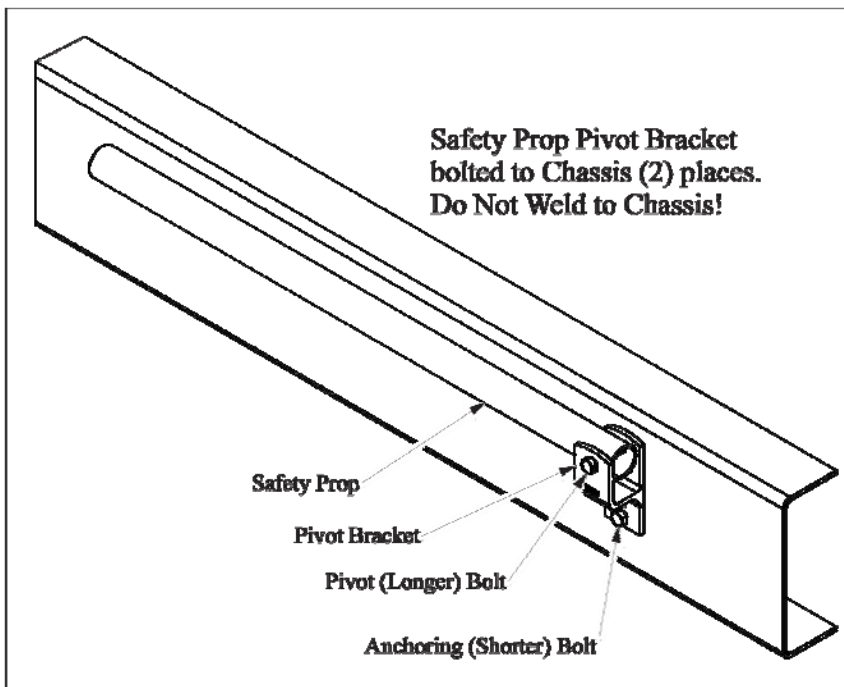

**Safety Prop Installation**

# Hoist Location on Trailer & "G" Dimension Measurements

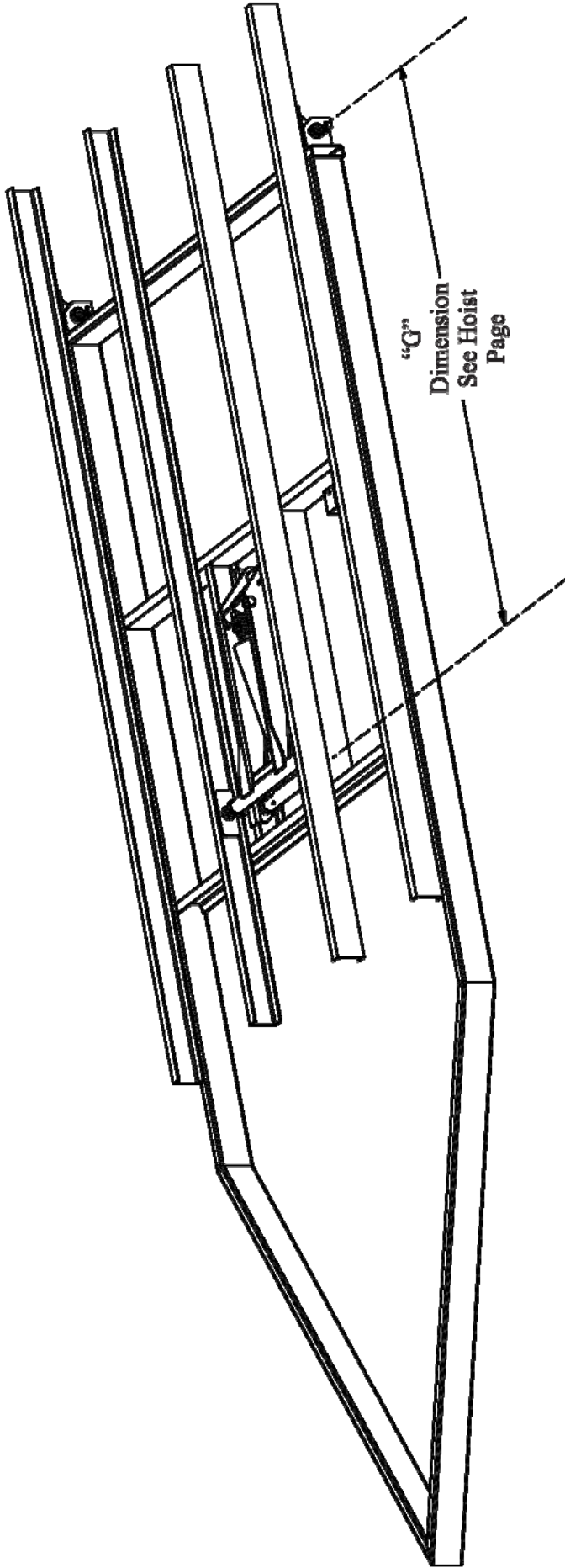

Trailer Hoist Statistics				
Trailer Hoist Models	Body Length (Feet)	Over Hang (Inches)	"G" Dimension (Inches)	
			Dump Angle	Dump Angle
CS412T	8 to 12	0 to 24	45°	50°
CS415T	9 to 12	0 to 24	62.5°	56.5°
CS515T	10 to 14	0 to 24	76°	69°
CS615T	10 to 16	0 to 24	76°	69°
CS520T	10 to 16	0 to 24	76°	69°
CS620T	12 to 16	0 to 24	105.5°	95.5°
CS628T	13 to 18	0 to 24	105.5°	95.5°
CS5520T	13 to 18	0 to 24	132°	119.5°
CS6620T	13 to 18	0 to 24	105.5°	95.5°
CS6620T	13 to 18	0 to 24	105.5°	95.5°

# Removing Slack from Hoist and Rear Hinge

## **IMPORTANT!**

SLACK MUST BE REMOVED FROM HOIST AND REAR HINGE DURING INSTALLATION.

## **INCORRECT INSTALLATION**

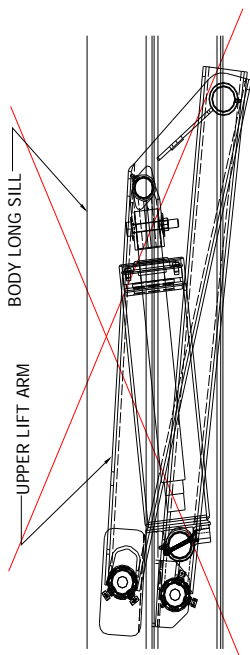

## **UPPER LIFT ARMS AND TOP OF LONG SILLS MUST BE PARALLEL.**

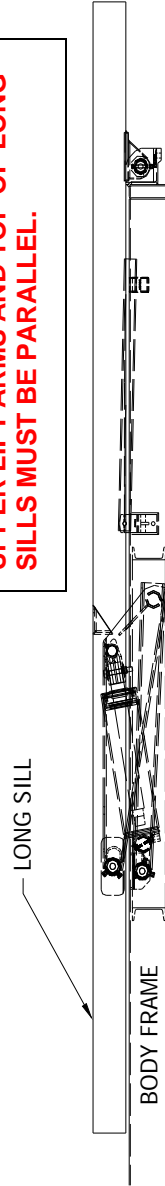

**NOTE:** Make sure to grease all Lubrication Fittings before operating.  
Refer to Hoist illustrations for fitting locations.

## **Procedure Steps:** (Refer to Illustration Left)

Using the Hoist Power, Raise the Body approximately 1-1/2" as measured from the end of bed.  
Weld Lift Arms to Long Sills using 3/8" continuous Fillet Weld. (See Below)  
Make sure Hoist is Centered within the Rails and secure in place with collars.

**Failure to perform this procedure as specified could cause Hoist Failure and therefore VOIDS Associated Warranty.**

## **CAUTION**

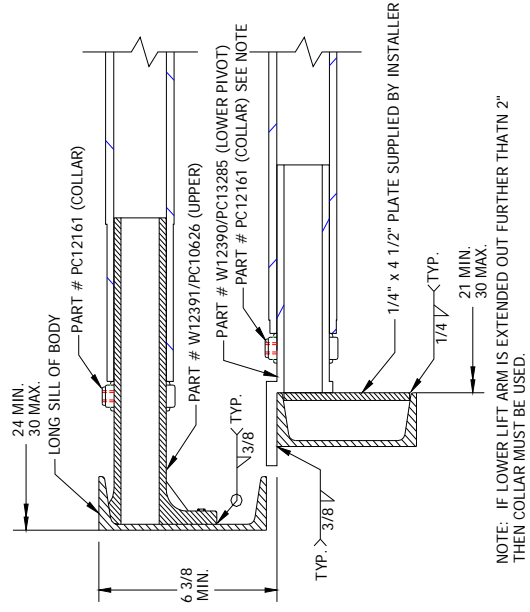

# Hoist and Dump Body Installation Procedure for Trailers

## Measuring the Trailer and Dump Body for correct installation

### Determine Rear Hinge Location and Install Hinge

**Note:** The following instructions are based on the assumption that care has been taken to properly match the trailer and dump body in length, width, and height. Care must also be taken to properly match the weights of the dump body and hoist to the trailer so as not to exceed the Gross Vehicle Weight Requirement (GVWR) of the trailer when fully loaded.

1. Prior to measuring the trailer for hoist and dump body installation, determine if the trailer has any obstructions on the tongue of the trailer that could interfere with the operation of the dump body.
2. Measure 3 inches from the rear of the obstruction towards the rear of the trailer along the top of the trailer chassis and mark the distance with a suitably bright marker pen, or a piece of brightly colored tape.
3. Measure and record the distance from the 3 inch mark to the end of the trailer chassis.
4. Measure and record the length of the Long Sills on the bottom of the dump body.

**Note:** The difference in these two lengths will determine how much Overhang is needed and/or how much must be removed from the rear of the trailer chassis.

5. Once the correct distance is determined, cut a notch into the ends of the chassis rails to accommodate the Rear Hinge Flipper Assembly and remove any excess rails.
6. Align the Rear Hinge Flipper Assembly in the notches and install it with a 1/2 inch continuous fillet weld on all contacting surfaces between the chassis rails and the rear hinge flipper assembly.

### Install Hoist Assembly

#### Determine Hoist Location and Install Hoist

1. Using an appropriate lifting device, i.e., overhead crane, place the hoist on the chassis and check approximate location on dump body for dump body Crossmember interference. The hoist may be repositioned slightly fore or aft to relieve any interference with trailer components.
2. The hoist must be located as near to the (side-to-side) center of the trailer and the dump body as possible.
3. Locate and mark centerline for rear hinge pivot.
4. Based on the hoist model, select the "G" dimension from the table associated with the hoist.
5. Mark the centerline of the lower mounting bracket on the hoist assembly. (This distance must equal the "G" dimension of the hoist. Refer to figure on page 14.)
6. After successful hoist location, drill trailer chassis and mount the lower mounting brackets, to the chassis using approved hardware.
7. Upper Lift Arms of hoist must be parallel with the top of the Chassis Rails and therefore the Long Sills of the body. (Refer to figure "Removing Slack from Hoist and Rear Hinge" above.)
8. Connect hydraulic lines to the hoist and use hoist controls to raise and lower the hoist to test operation.

### Install Dump Body

 **DANGER** Dump Bodies are very heavy!  
Be careful when lifting or moving.

#### Determine Body Location and Install Body

1. Using an appropriate lifting device, i.e., overhead crane, place the body on the chassis and check for correct alignment with chassis. Be sure that the body is aligned with the measurements in the steps above.
2. Weld Rear Hinge Flippers to the dump body with a 1/2 inch continuous fillet weld.
3. Using the hoist controls, raise the body 1-1/2" as measured from the front end of the body.
4. Weld Lift Arms to the Long Sills of the body using a 3/8" continuous fillet weld.
5. Using the hoist controls, raise the body high enough to engage the Safety Prop.
6. Inspect all welds and check operation of Hoist and Body.
7. Allow welds to cool and grease all Pivot Points and grease fittings with EP-2 chassis grease, or equivalent. (Refer to Hoist Dimensions, Capacities, & Parts pages of Hoist for grease fitting locations.)

# CS412T Capacities

CS412T Hoist Capacity (Tons)			
Body Length (Feet)	Overhang (Inches)	Dump Angle (Degrees) "G" Dimension (Inches)	
		45 Deg. (62.5 Inches)	50 Deg. (56.5 Inches)
8	0	5.70	5.20
8	12	7.70	6.90
8	18	9.20	8.30
8	24	11.50	10.40
9	0	5.10	4.60
9	12	6.60	5.90
9	18	7.70	6.90
9	24	9.20	8.30
10	0	4.60	4.20
10	12	5.70	5.20
10	18	6.60	5.90
10	24	7.70	6.90
11	0	4.20	3.80
11	12	5.10	4.60
11	18	5.70	5.20
11	24	6.60	5.90
12	0	3.80	3.50
12	12	4.60	4.20
12	18	5.10	4.60
12	24	5.70	5.20

**CHAMPION**  
 Hoist and Equipment   
 Dunn, North Carolina, U.S.A.  
 910 - 897 - 4995  
 Fax 910 - 897 - 6822



# CS412T Dimensions

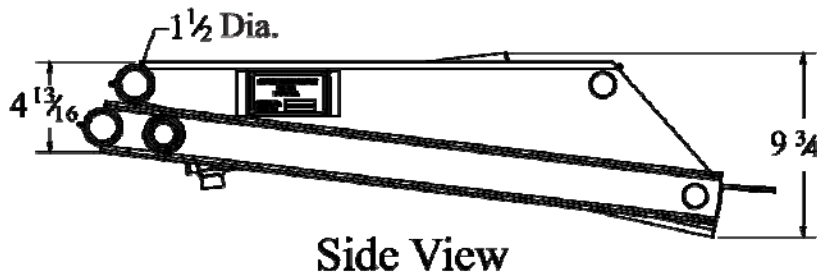
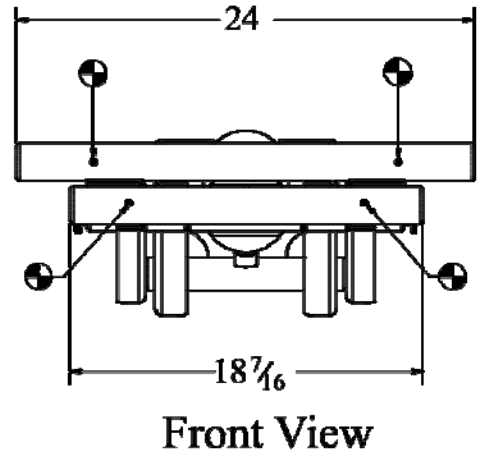
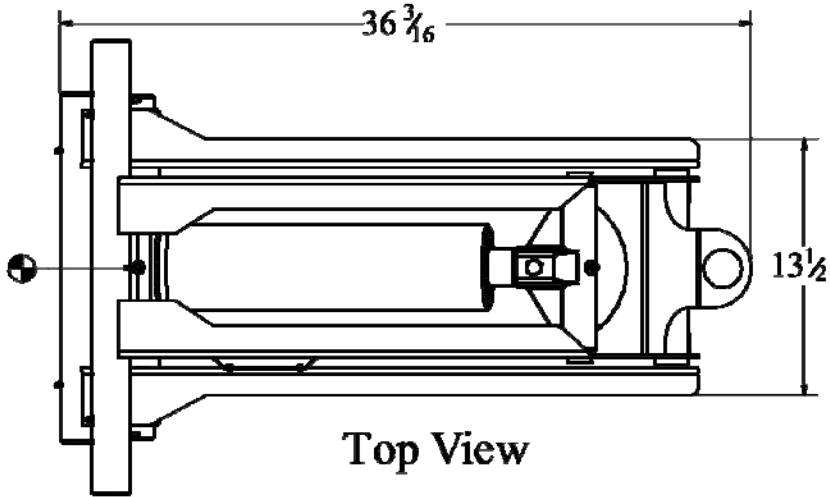

 Grease Fitting Locations

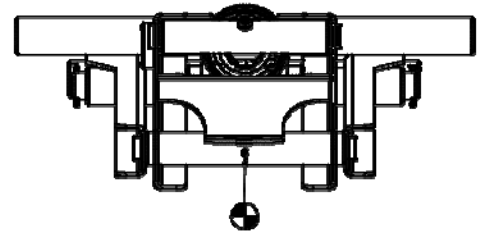
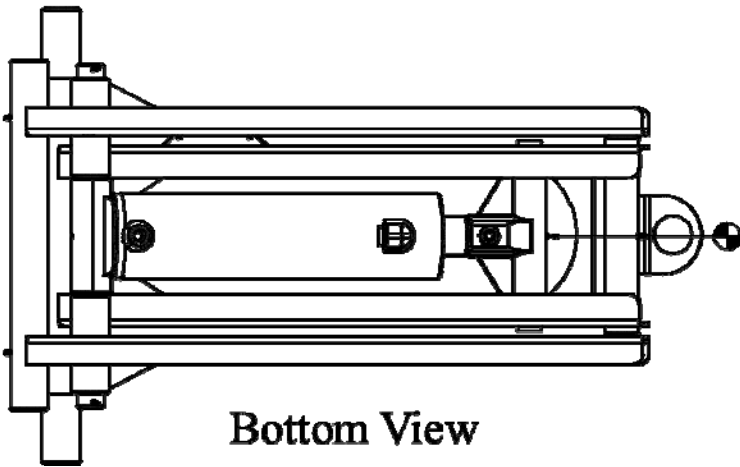

# CHAMPION

Hoist and Equipment

Dunn, North Carolina, U.S.A.

910 - 897 - 4995

Fax 910 - 897 - 6822

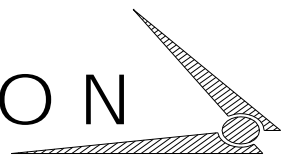

# CS412T Parts List

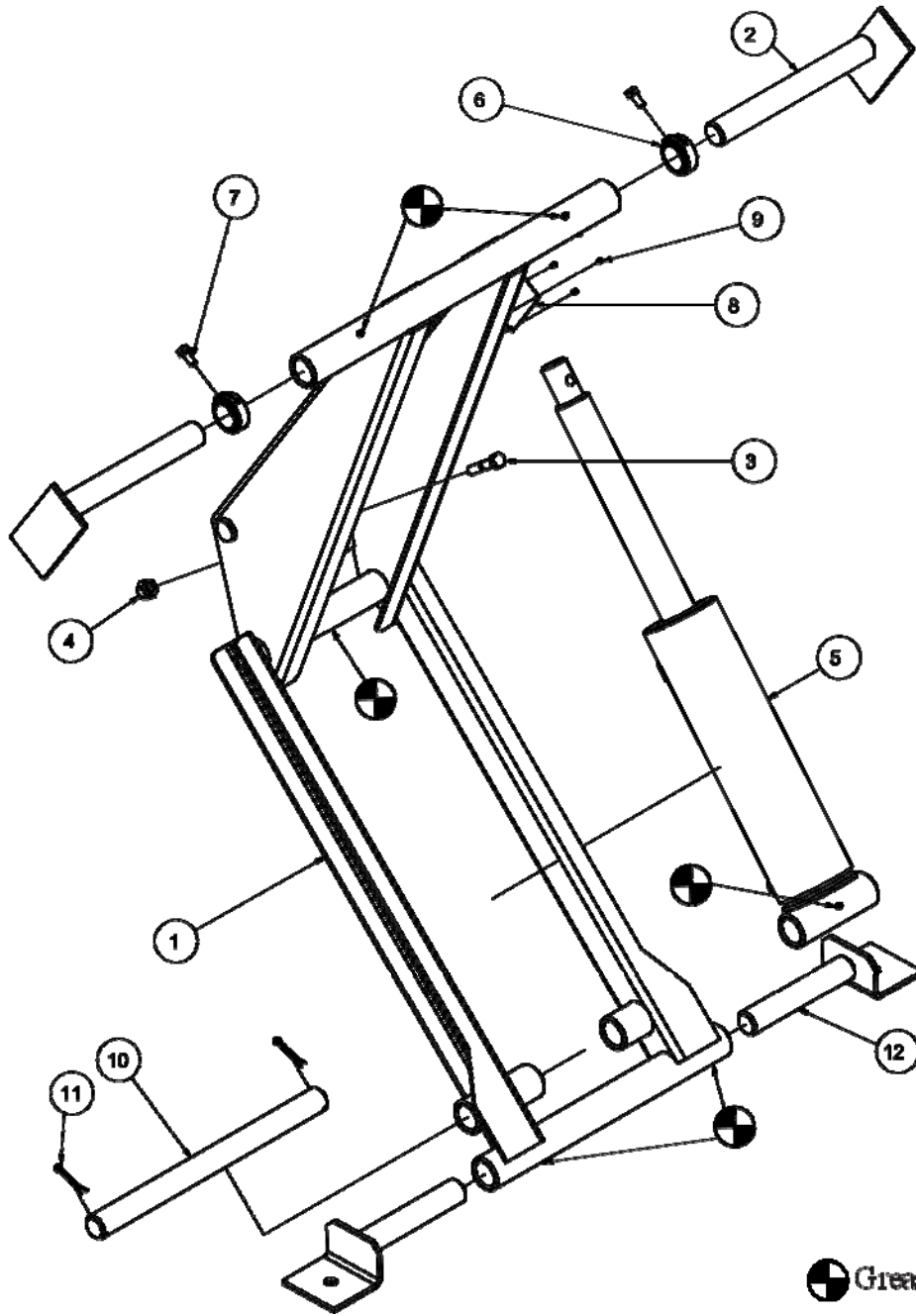

**CS412T Parts List (refer to engineering drawing A12454)**

Item	Qty.	Part Number	Description
1	1	W12439	Scissor Hoist Weldment, CS412T
2	2	W12451	Upper lift Arm Weldment, CS412T
3	1	102-411-A1	Hex Bolt, 1/2" x 2 1/2"
4	1	162-10-S	Lock Nut, 1/2"
5	1	A21324	Cylinder Assembly 412
6	2	PC12458	Collar, Lift Arm 1-7/16"
7	2	P34	Set Screw 3/8"-16 x 3/4" Square Head
8	1	P10100	Serial Plate
9	4	PAAP43	Rivet, 1/8" Cherry Pop
10	1	SM12580	Bottom Cylinder Shaft, 412T
11	2	125-256	Pin, Cotter
12	2	W12582	Lower Lift Point Weldment 412T



# CS412T Rear Hinge Assembly

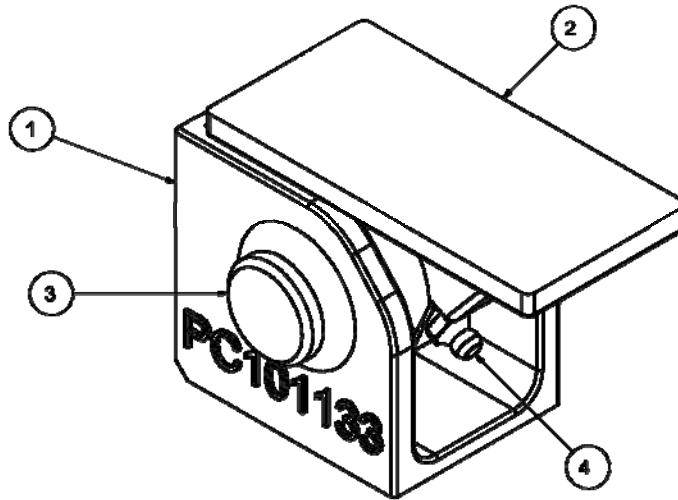

PARTS LIST			
ITEM	QTY	PART NUMBER	DESCRIPTION
1	1	PC101133	REAR HINGE SUPPORT, 1"
2	1	PC101134	HINGE BLOCK, 1"
3	1	S13823	REAR HINGE PIN, 1"
4	1	P800	1/8" PIPE THREAD GREASE FITTING

# CHAMPION

Hoist and Equipment

Dunn, North Carolina, U.S.A.

910 - 897 - 4995

Fax 910 - 897 - 6822

## CS415T Capacities

<b>CS415T Hoist Capacity (Tons)</b>			
<b>Body Length (Feet)</b>	<b>Overhang (Inches)</b>	<b>Dump Angle (Degrees) "G" Dimension (Inches)</b>	
		<b>45 Deg.(76 Inches)</b>	<b>50 Deg. (69 Inches)</b>
9	0	5.50	5.00
	12	7.10	6.40
	18	8.20	7.50
	24	9.90	9.00
10	0	4.90	4.50
	12	6.20	5.60
	18	7.10	6.40
	24	8.20	7.50
11	0	4.50	4.10
	12	5.50	5.00
	18	6.20	5.60
	24	7.10	6.40
12	0	4.10	3.70
	12	4.90	4.50
	18	5.50	5.00
	24	6.20	5.60

**C H A M P I O N**

Hoist and Equipment

Dunn, North Carolina, U.S.A.

910 - 897 - 4995

Fax 910 - 897 - 6822

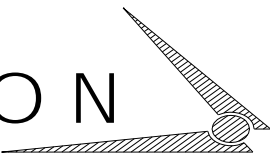

# CS415T Dimensions

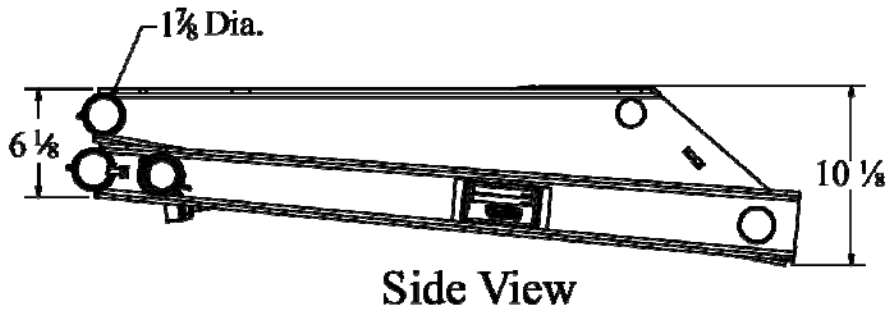
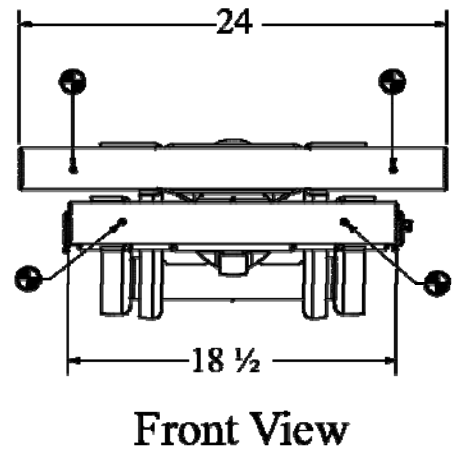
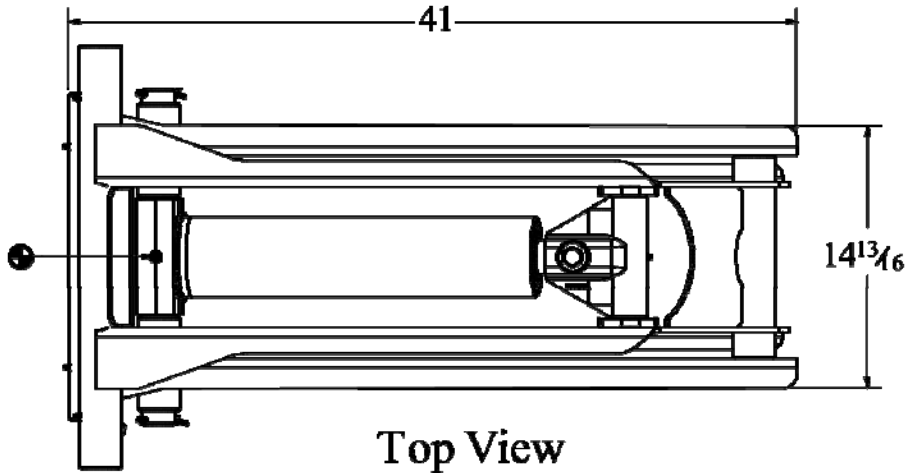

 Grease Fitting Locations

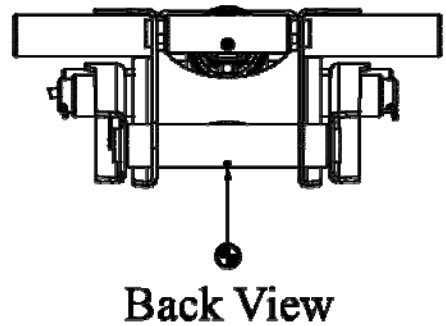
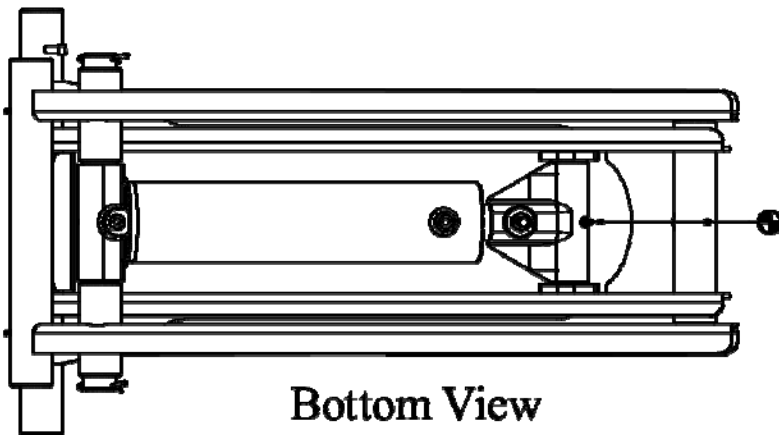

## CHAMPION

Hoist and Equipment

Dunn, North Carolina, U.S.A.

910 - 897 - 4995

Fax 910 - 897 - 6822

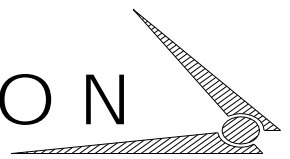

# CS415T Parts List

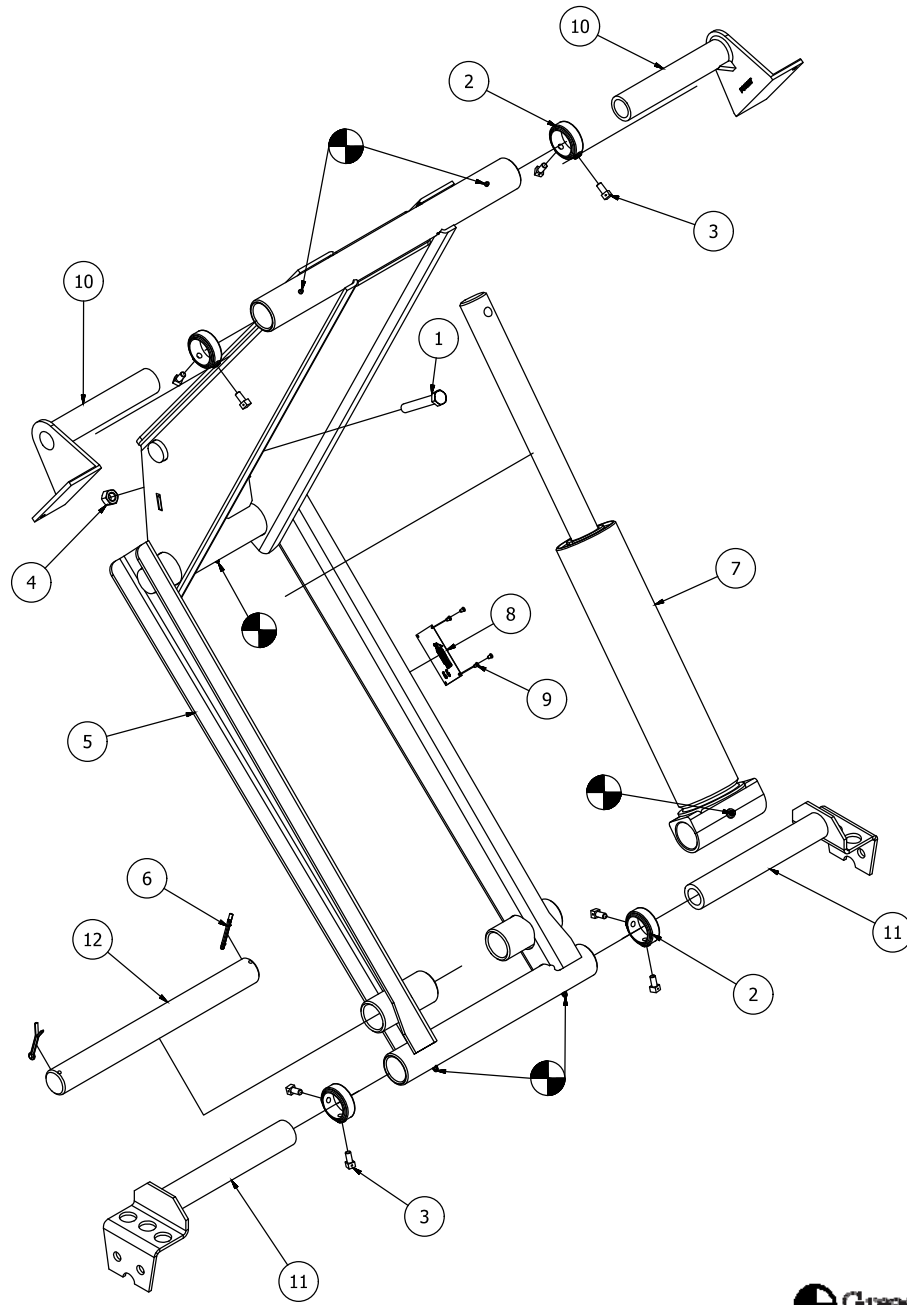

 Grease Fitting Locations

**CS415T Parts List (refer to engineering drawing A12673)**

Item	Qty.	Part Number	Description
1	1	102-617-L	Hex Cap Screw, 5/8 x 4, GR 9
2	4	PC12161	Collar, Lift Arm 1-7/8"
3	8	P34	Set Screw 3/8"-16 x 3/4" Square Head
4	1	143-7	Nylon Lock Nut, 5/8"
5	2	W12334	Scissor Hoist Weldment, 415T
6	2	125-259	Cotter Pin, 1/4" x 2 1/2"
7	1	A21321	Cylinder Assembly 415 DA
8	1	P10200	Serial Plate
9	4	PAAP43	Rivet, 1/8" Cherry Pop
10	2	PC12573	Upper Lift Arm Weldment, 415T
11	2	PC12574	Lower Lift Point Weldment 415T
12	1	SM12016	Bottom Cylinder Shaft, 415T
13	2	PC12572	2" Spacer

## CS515T Capacities

CS515T Hoist Capacity (Tons)			
Body Length (Feet)	Overhang (Inches)	Dump Angle (Degrees) "G" Dimension (Inches)	
		45 Deg.(76 Inches)	50 Deg. (69 Inches)
10	0	7.70	7.00
	12	9.70	8.80
	18	11.00	10.00
	24	12.90	11.70
11	0	7.00	6.40
	12	8.60	7.80
	18	9.70	8.80
	24	11.00	10.00
12	0	6.40	5.80
	12	7.70	7.00
	18	8.60	7.80
	24	9.70	8.80
13	0	5.90	5.40
	12	7.00	6.40
	18	7.70	7.00
	24	8.60	7.80
14	0	5.50	5.00
	12	6.40	5.80
	18	7.00	6.40
	24	7.70	7.00

# CHAMPION

Hoist and Equipment

Dunn, North Carolina, U.S.A.

910 - 897 - 4995

Fax 910 - 897 - 6822

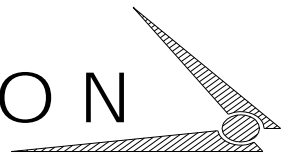

# CS515T Dimensions

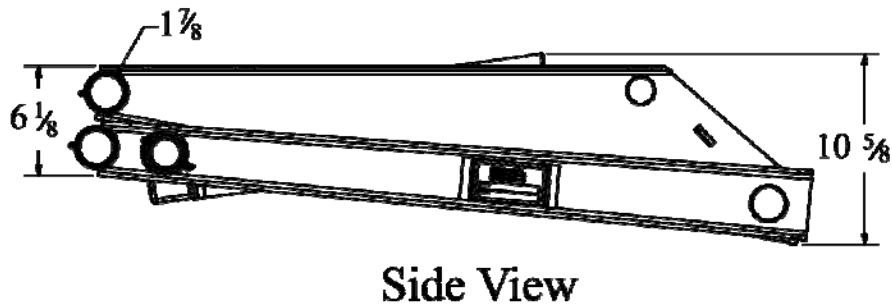
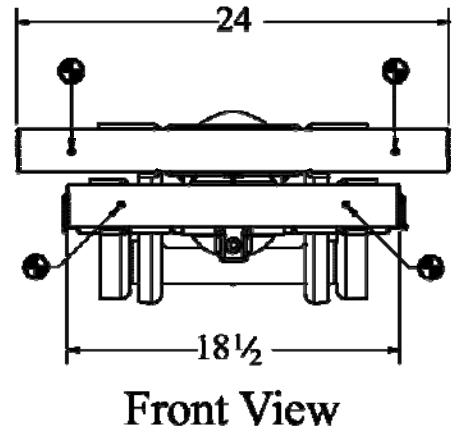
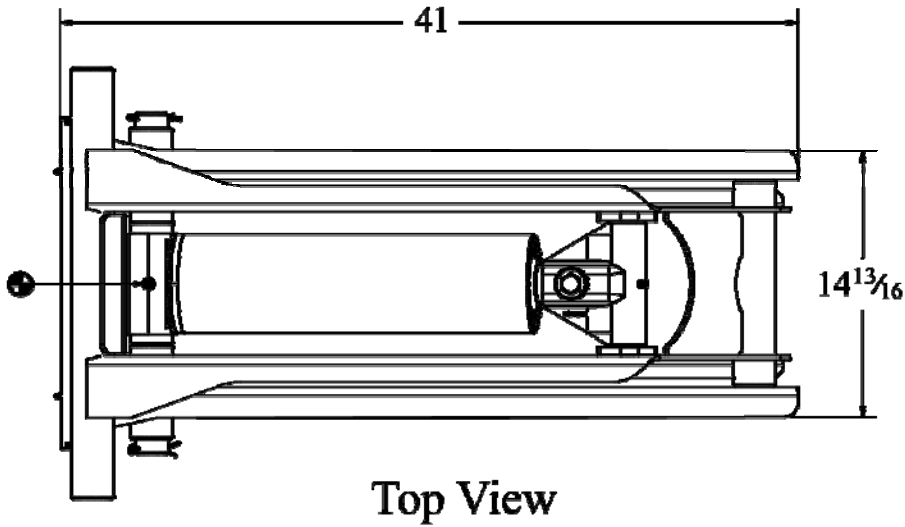

 Grease Fitting Locations

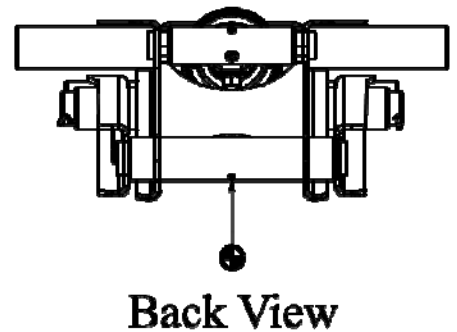
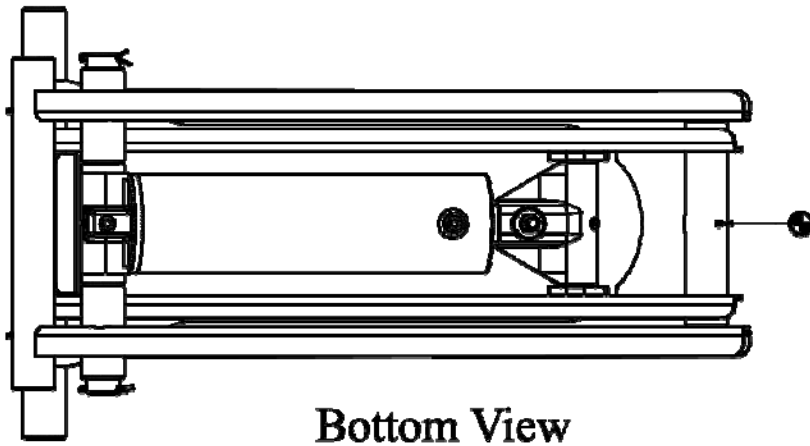

**CHAMPION**

Hoist and Equipment  
 Dunn, North Carolina, U.S.A.  
 910 - 897 - 4995  
 Fax 910 - 897 - 6822

# CS515T Parts List

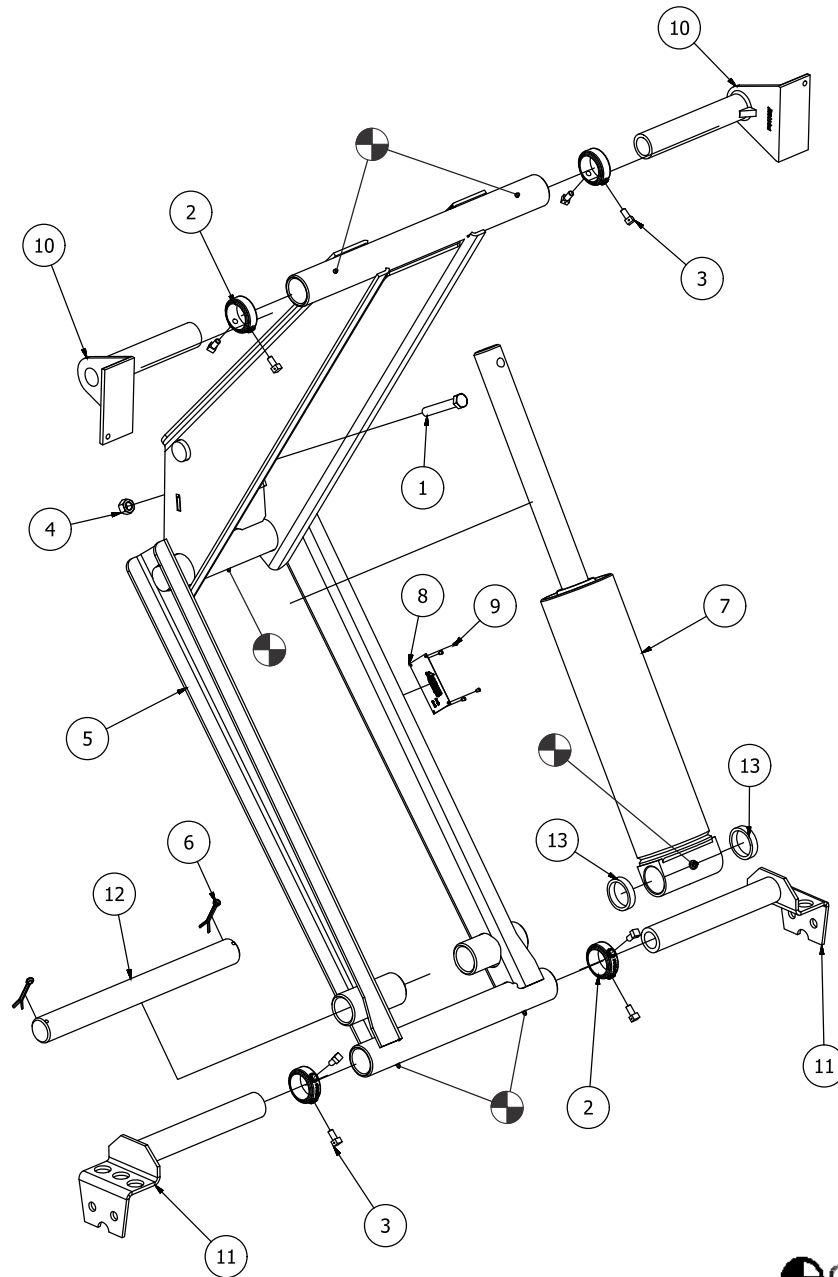

CS515T Parts List (refer to engineering drawing A12674)

Item	Qty.	Part Number	Description
1	1	A21322	Cylinder Assembly, 515 DA
2	1	102-617-L	Hex Cap Screw, 5/8 x 4, GR 9
3	4	PC12161	Collar, Lift Arm 1-7/8"
4	8	P34	Set Screw 3/8"-16 x 3/4" Square Head
5	1	143-7	Nylon Lock Nut, 5/8"
6	1	W12334	Scissor Hoist Weldment, 515T
7	2	125-259	Cotter Pin, 1/4" x 2 1/2"
8	2	PC12573	Upper lift Arm Weldment, 515T
9	2	PC12574	Lower Lift Point Weldment 515T
10	4	PAAP43	Rivet, 1/8" Cherry Pop
11	2	PC12572	2" Spacer
12	1	P10200	Serial Plate
13	1	PC12651	Bottom Cylinder Shaft, 515T

## CS615T Capacities

<b>CS615T Hoist Capacity (Tons)</b>			
Body Length (Feet)	Overhang (Inches)	Dump Angle (Degrees) "G" Dimension (Inches)	
		45 Deg.(76 Inches)	50 Deg. (69 Inches)
10	0	11.10	10.10
	12	13.90	12.60
	18	15.90	14.40
	24	18.50	16.80
11	0	10.10	9.20
	12	12.40	11.20
	18	13.90	12.60
	24	15.90	14.40
12	0	9.30	8.40
	12	11.10	10.10
	18	12.40	11.20
	24	13.90	12.60
13	0	8.60	7.80
	12	10.10	9.20
	18	11.10	10.10
	24	12.40	11.20
14	0	7.90	7.20
	12	9.30	8.40
	18	10.10	9.20
	24	11.10	10.10
15	0	7.40	6.70
	12	8.60	7.80
	18	9.30	8.40
	24	10.10	9.20
16	0	7.00	6.30
	12	7.90	7.20
	18	8.60	7.80
	24	9.30	8.40



**CHAMPION**  
 Hoist and Equipment  
 Dunn, North Carolina, U.S.A.  
 910 - 897 - 4995  
 Fax 910 - 897 - 6822

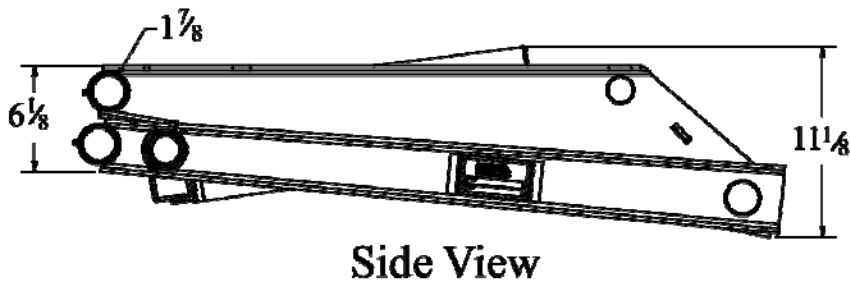
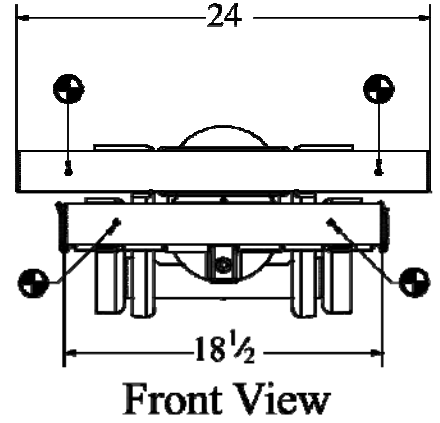
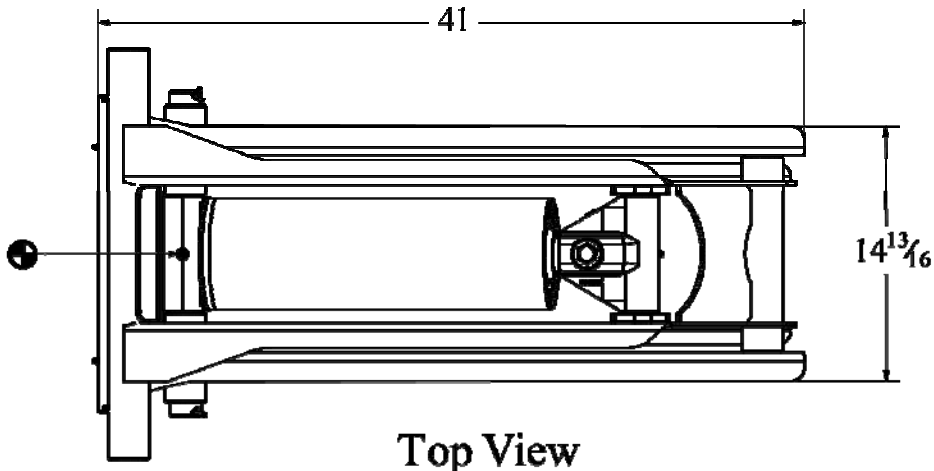

# CS615T Dimensions

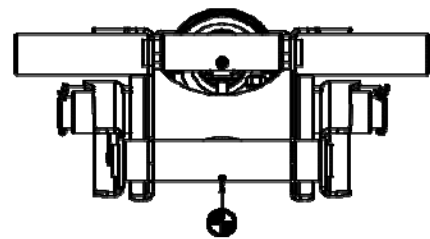
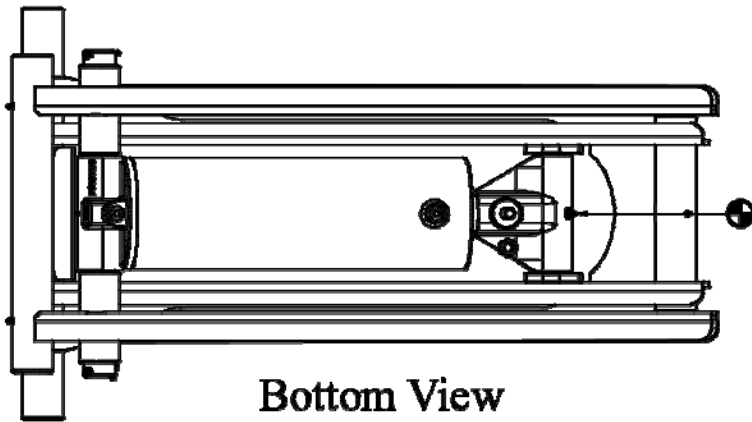

 Grease Fitting Locations



**CHAMPION**

Hoist and Equipment  
 Dunn, North Carolina, U.S.A.  
 910 - 897 - 4995  
 Fax 910 - 897 - 6822

# CS615T Parts List

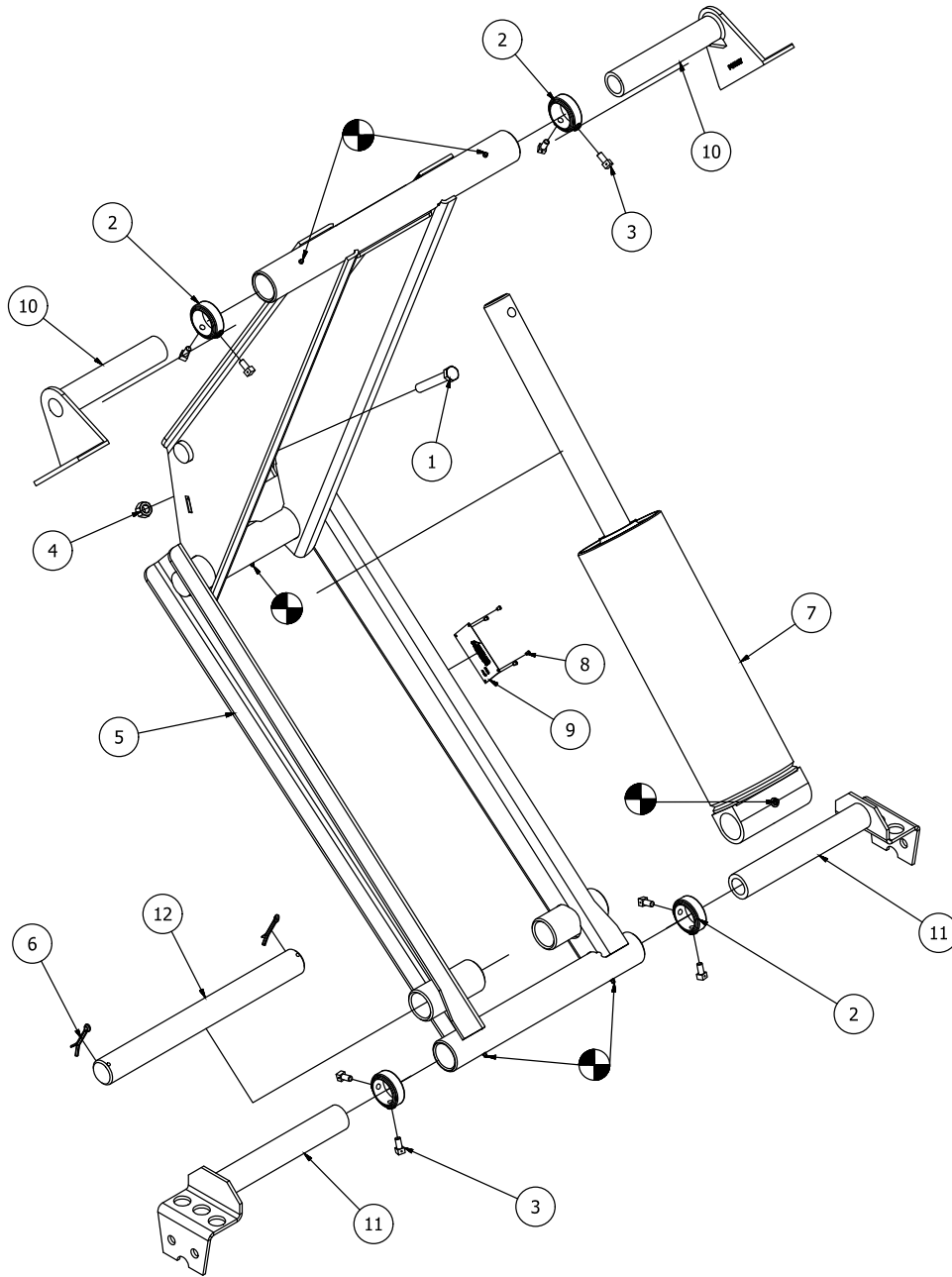

Grease Fitting Locations

**CS615T Parts List (refer to engineering drawing A12675)**

Item	Qty.	Part Number	Description
1	1	102-617-L	Hex Cap Screw, 5/8 x 4, GR 9
2	4	PC12161	Collar, Lift Arm 1-7/8"
3	8	P34	Set Screw 3/8"-16 x 3/4" Square Head
4	1	143-7	Nylon Lock Nut, 5/8"
5	1	W12334	Scissor Hoist Weldment, 615T
6	2	125-259	Cotter Pin, 1/4" x 2 1/2"
7	1	A21323	Cylinder Assembly, 615DA
8	4	PAAP43	Rivet, 1/8" Cherry Pop
9	1	P10200	Serial Plate
10	2	PC12573	Upper Lift Arm Weldment, 615T
11	2	PC12574	Lower Lift Point Weldment 615T
12	1	SM12016	Bottom Cylinder Shaft, 615T

# CS415T/CS515T/CS615T Rear Hinge Assembly

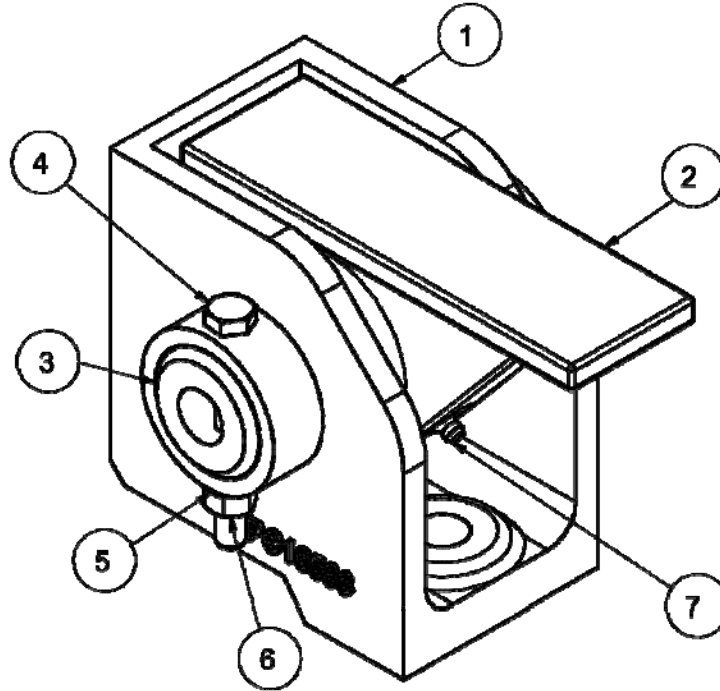

415T/515T/615T Rear Hinge Assembly - Parts List			
Item	Qty.	Part Number	Description
1	1	PC10583	Rear Hinge Block, 1-3/4"
2	1	PC10636	Hinge Flipper, 1-3/4"
3	1	PC10816	1-3/4" Rear Hinge Pin, Short Version
4	1	102-214	Hex Cap Screw, 3/8 X 3 1/4
5	1	118-3-A1	Lock Washer, 3/8
6	1	116-3-A1	Hex Nut, 3/8 UNC
7	1	P800	1/8" Pipe Thread Grease Fitting

## CHAMPION

Hoist and Equipment

Dunn, North Carolina, U.S.A.

910 - 897 - 4995

Fax 910 - 897 - 6822

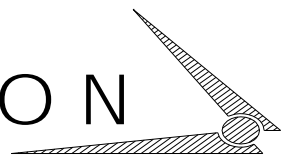

## CS520T Capacities

<b>CS520T Hoist Capacity (Tons)</b>			
Body Length (Feet)	Overhang (Inches)	Dump Angle (Degrees) "G" Dimension (Inches)	
		45 Deg. (105.5 Inches)	50 Deg. (95.5 Inches)
10	0	10.20	9.20
	12	12.80	11.60
	18		13.20
	24		15.40
11	0	9.30	8.40
	12	11.30	10.30
	18	12.80	11.60
	24	14.60	13.20
12	0	8.50	7.70
	12	10.20	9.20
	18	11.30	10.30
	24	12.80	11.60
13	0	7.90	7.10
	12	9.30	8.40
	18	10.20	9.20
	24	11.30	10.30
14	0	7.30	6.60
	12	8.50	7.70
	18	9.30	8.40
	24	10.20	9.20
15	0	6.80	6.20
	12	7.90	7.10
	18	8.50	7.70
	24	9.30	8.40
16	0	6.40	5.80
	12	7.30	6.60
	18	7.90	7.10
	24	8.50	7.70

**C H A M P I O N**

Hoist and Equipment

Dunn, North Carolina, U.S.A.

910 - 897 - 4995

Fax 910 - 897 - 6822

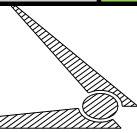

# CS520T Dimensions

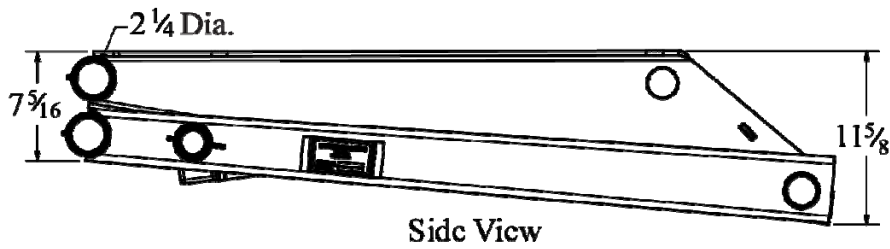
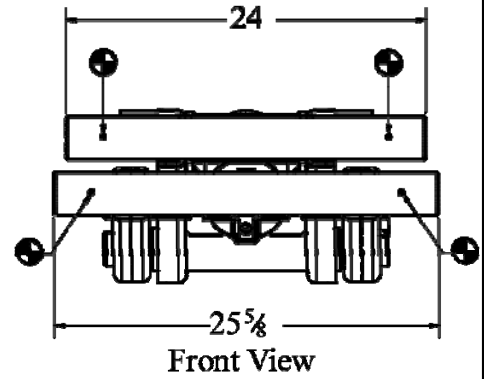
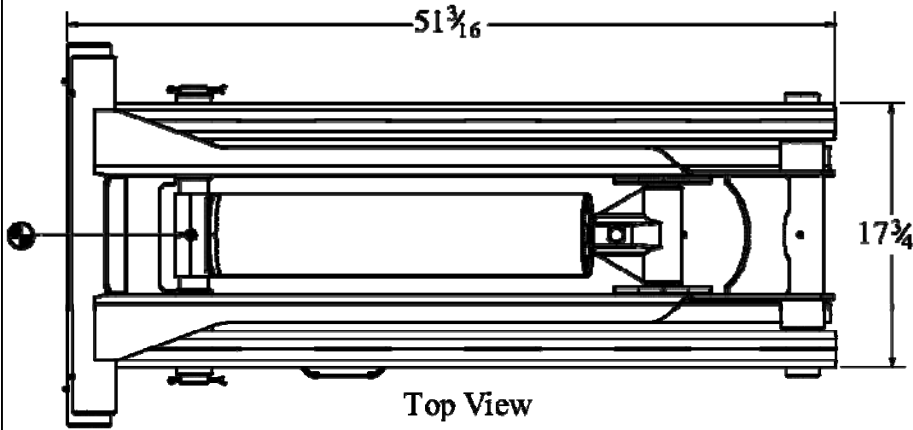

 Grease Fitting Locations

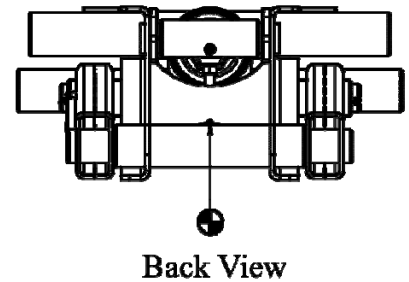
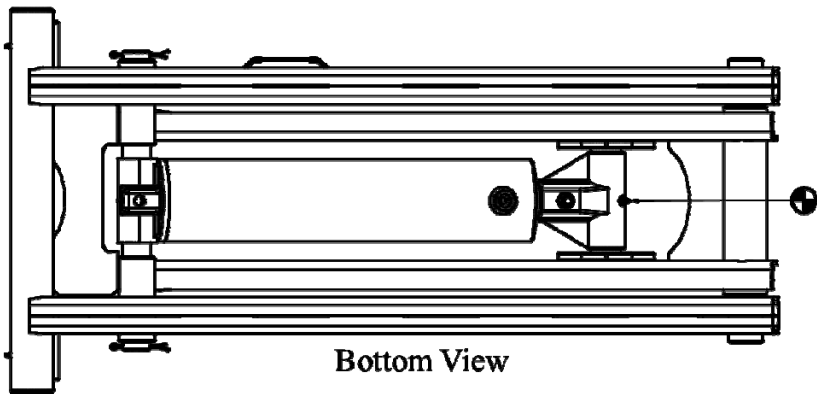

# CHAMPION

Hoist and Equipment

Dunn, North Carolina, U.S.A.

910 - 897 - 4995

Fax 910 - 897 - 6822

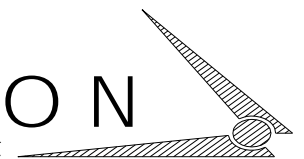

# CS520T Parts List

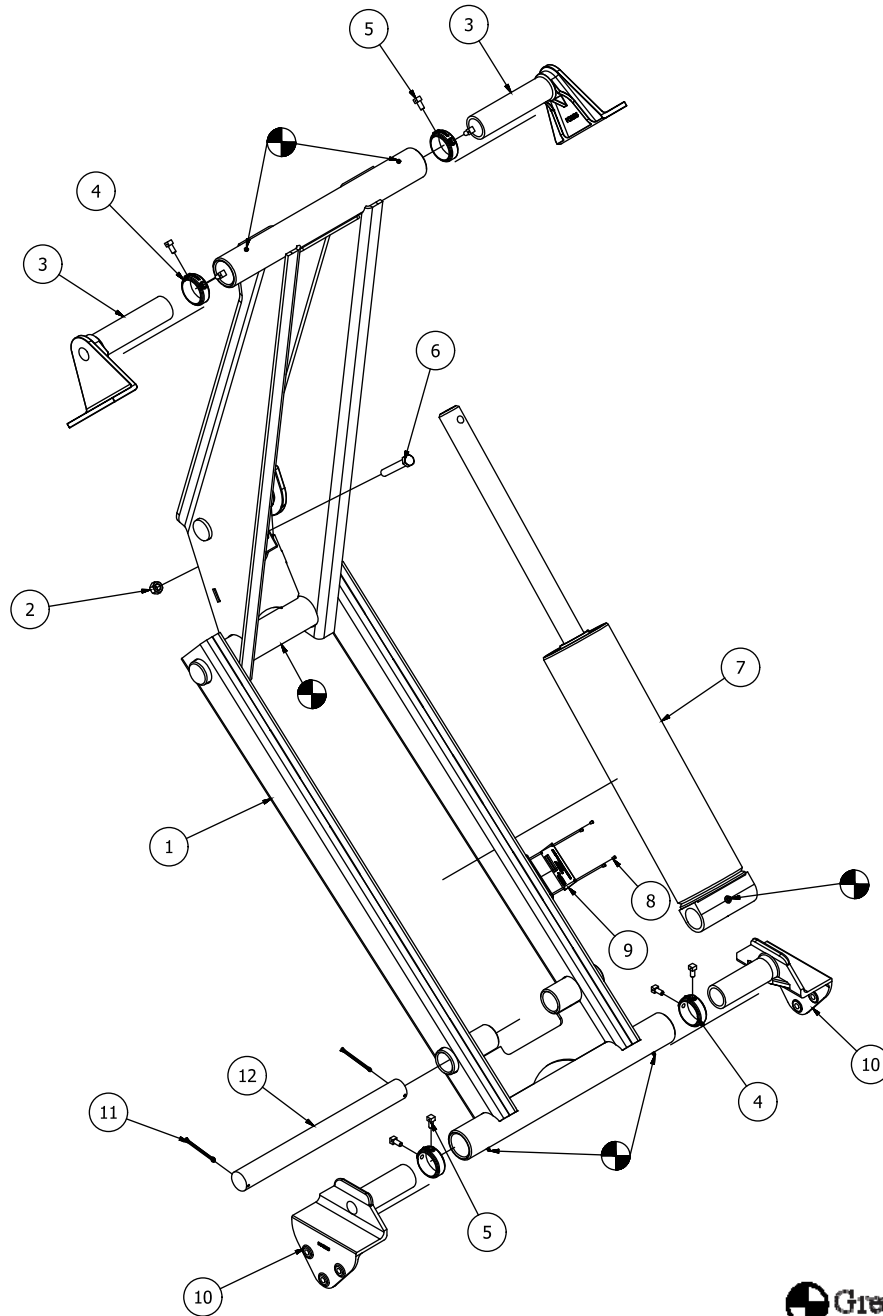

CS520T Parts List (refer to engineering drawing A12340)

Item	Qty.	Part Number	Description
1	1	102-617-A1	Hex Cap Screw, 5/8 x 4
2	2	125-257	Cotter Pin, 2"
3	1	162-10-S	Lock Nut, 1/2"
4	1	A21359	Cylinder Assembly, 520 DA
5	8	P34	Set Screw 3/8"-16 x 3/4" Square Head
6	4	PC12157	Set Collar for Upper Lift Arm 2-1/4"
7	1	PC12600	Cylinder Mount Shaft, 520T
8	1	W12335	Scissor Hoist Weldment, 520T
9	2	W13905	Lower Lift Arm Weldment, 2-1/4" 520T
10	2	W13922	Upper Lift Arm Weldment, 2-1/4" 520T
11	1	P10100	Serial Plate
12	4	PAAP43	Rivet, 1/8" Cherry Pop

## CS620T Capacities

<b>CS620T Hoist Capacity (Tons)</b>			
<b>Body Length (Feet)</b>	<b>Overhang (Inches)</b>	<b>Dump Angle (Degrees) "G" Dimension (Inches)</b>	
		<b>45 Deg.(105.5 Inches)</b>	<b>50 Deg. (95.5 Inches)</b>
12	0	12.30	11.10
	12	14.70	13.30
	18	16.30	14.80
	24	18.40	16.60
13	0	11.30	10.20
	12	13.40	12.10
	18	14.70	13.30
	24	16.30	14.80
14	0	10.50	9.50
	12	12.30	11.10
	18	13.40	12.10
	24	14.70	13.30
15	0	9.80	8.90
	12	11.30	10.20
	18	12.30	11.10
	24	13.40	12.10
16	0	9.20	8.30
	12	10.50	9.50
	18	11.30	10.20
	24	12.30	11.10

# CHAMPION

Hoist and Equipment

Dunn, North Carolina, U.S.A.

910 - 897 - 4995

Fax 910 - 897 - 6822

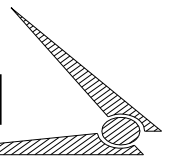

# CS620T Dimensions

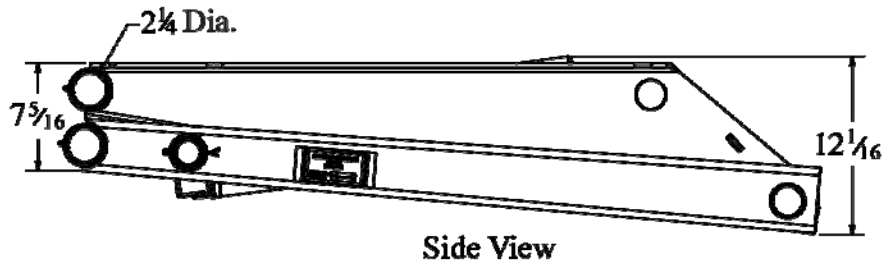
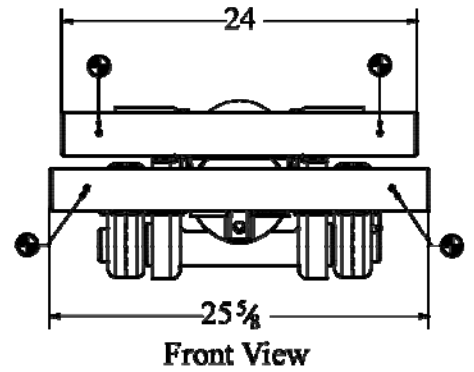
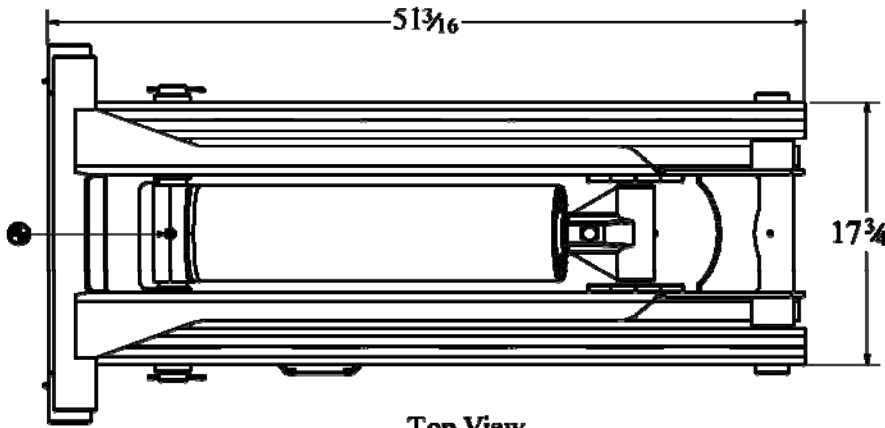

 Grease Fitting Locations

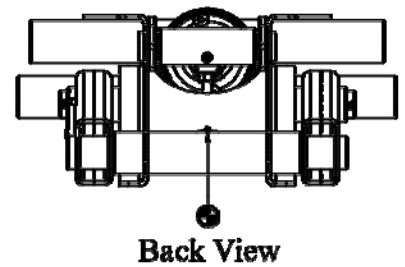
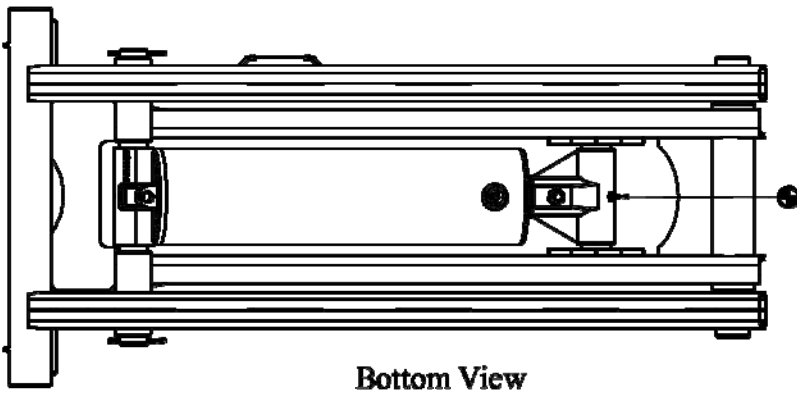

# CHAMPION

Hoist and Equipment

Dunn, North Carolina, U.S.A.

910 - 897 - 4995

Fax 910 - 897 - 6822

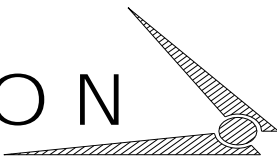



# CS620T Parts List

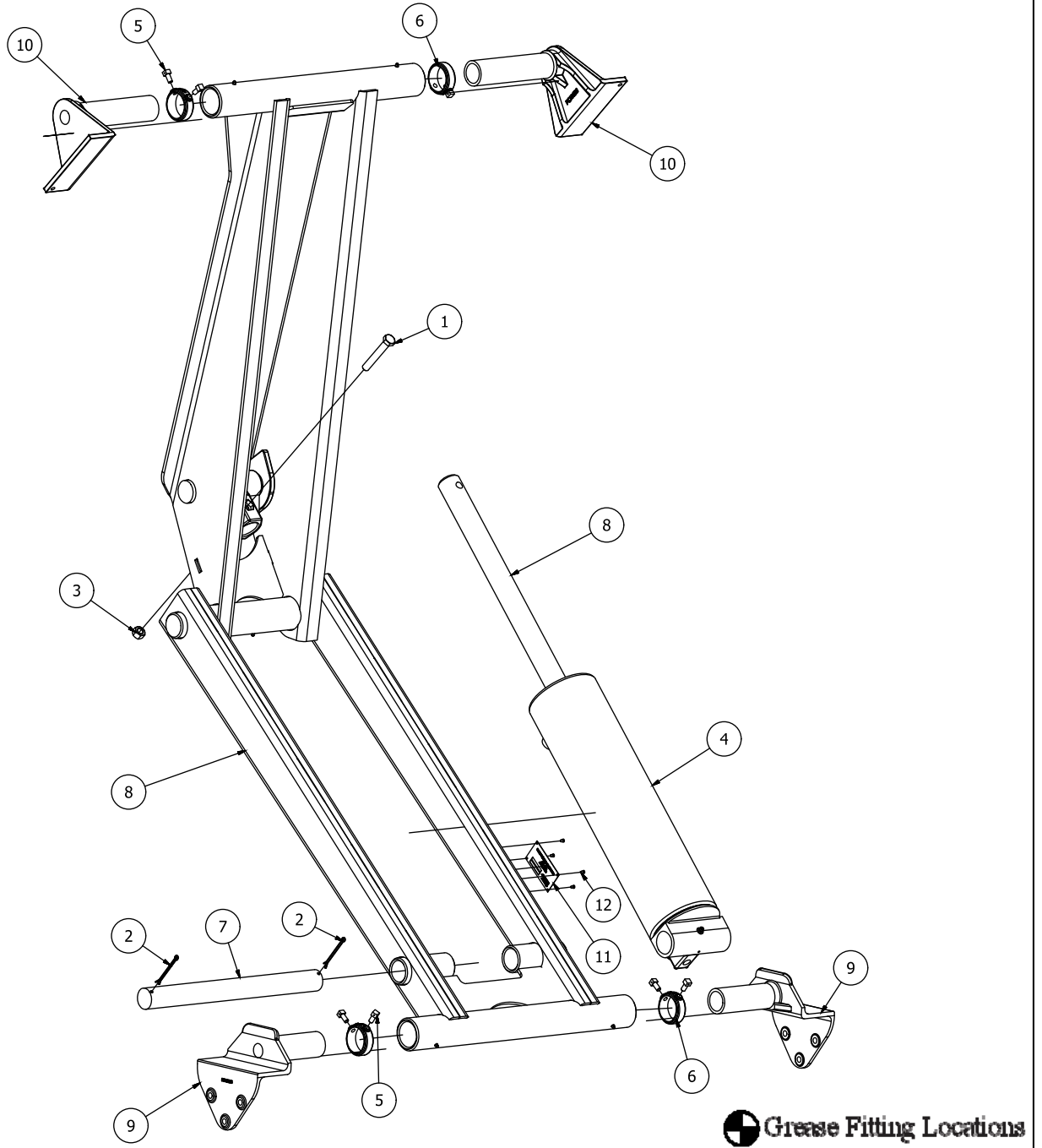

**CS620T Parts List (refer to engineering drawing A12341)**

Item	Qty.	Part Number	Description
1	1	102-617-A1	Hex Cap Screw, 5/8 x 4
2	2	125-257	Cotter Pin, 2"
3	1	162-10-S	Lock Nut, 1/2"
4	1	A21328	Cylinder Assembly, 620 DA
5	8	P34	Set Screw 3/8"-16 x 3/4" Square Head
6	4	PC12157	Set Collar for Upper Lift Arm 2-1/4"
7	1	PC12600	Cylinder Mount Shaft, 620T
8	1	W12335	Scissor Hoist Weldment, 620T
9	2	W13905	Lower Lift Arm Weldment, 2-1/4" 620T
10	2	W13922	Upper Lift Arm Weldment, 2-1/4" 620T
11	1	P10100	Serial Plate
12	4	PAAP43	Rivet, 1/8" Cherry Pop

# CS520T/CS620T Rear Hinge Assembly

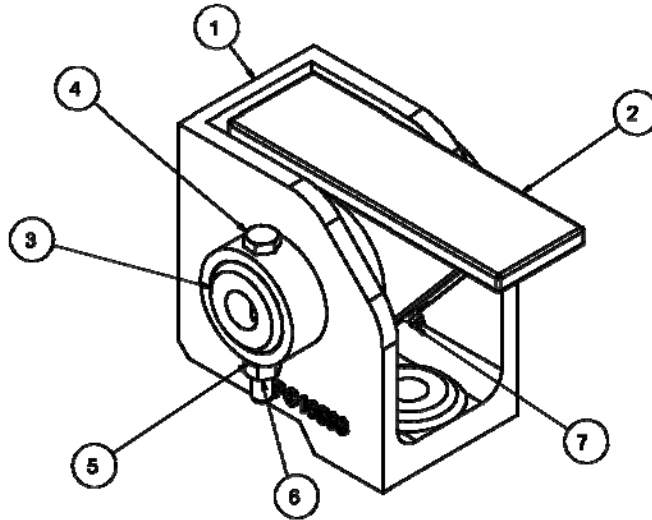

520T/620T REAR HINGE ASSEMBLY - PARTS LIST			
Item	Qty.	Part Number	Description
1	1	PC10583	Rear Hinge Block, 1-3/4"
2	1	PC10636	Hinge Flipper, 1-3/4"
3	1	PC10816	1-3/4" Rear Hinge Pin, Short Version
4	1	102-214	Hex Cap Screw, 3/8 X 3 1/4
5	1	118-3-A1	Lock Washer, 3/8
6	1	116-3-A1	Hex Nut, 3/8 UNC
7	1	P800	1/8" Pipe Thread Grease Fitting

# CHAMPION

Hoist and Equipment  
Dunn, North Carolina, U.S.A.

910 - 897 - 4995  
Fax 910 - 897 - 6822

## CS5520T Capacities

<b>CS5520T Hoist Capacity (Tons)</b>			
<b>Body Length (Feet)</b>	<b>Overhang (Inches)</b>	<b>Dump Angle (Degrees) "G" Dimension (Inches)</b>	
		<b>45 Deg.(105.5 Inches)</b>	<b>50 Deg. (95.5 Inches)</b>
13	0	15.70	14.20
	12	18.60	16.80
	18	20.40	18.50
	24	22.70	20.50
14	0	14.60	13.20
	12	17.00	15.40
	18	18.60	16.80
	24	20.40	18.50
15	0	13.60	12.30
	12	15.70	14.20
	18	17.00	15.40
	24	18.60	16.80
16	0	12.80	11.60
	12	14.60	13.20
	18	15.70	14.20
	24	17.00	15.40
18	0	11.30	10.30
	12	12.80	11.60
	18	13.60	12.30
	24	14.60	13.20

# CHAMPION

Hoist and Equipment

Dunn, North Carolina, U.S.A.

910 - 897 - 4995

Fax 910 - 897 - 6822

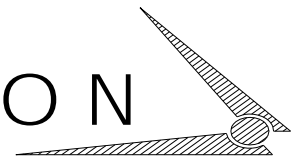

# CS5520T Dimensions

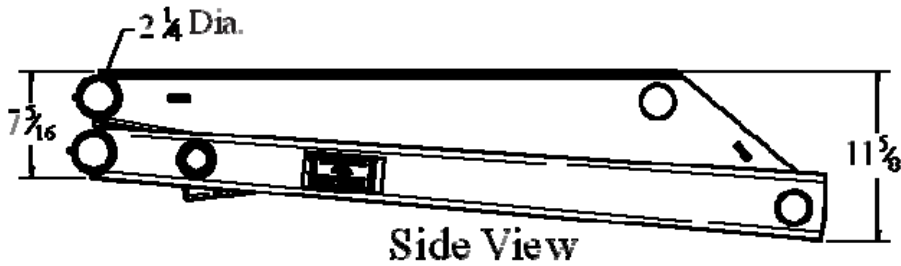
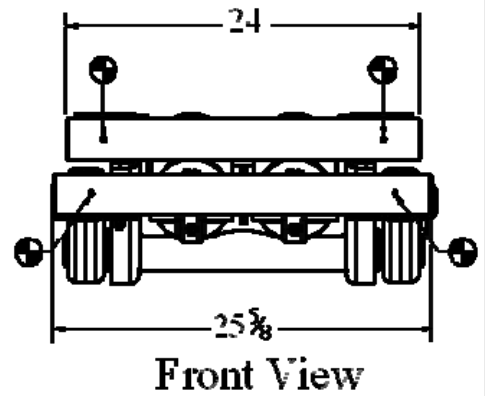
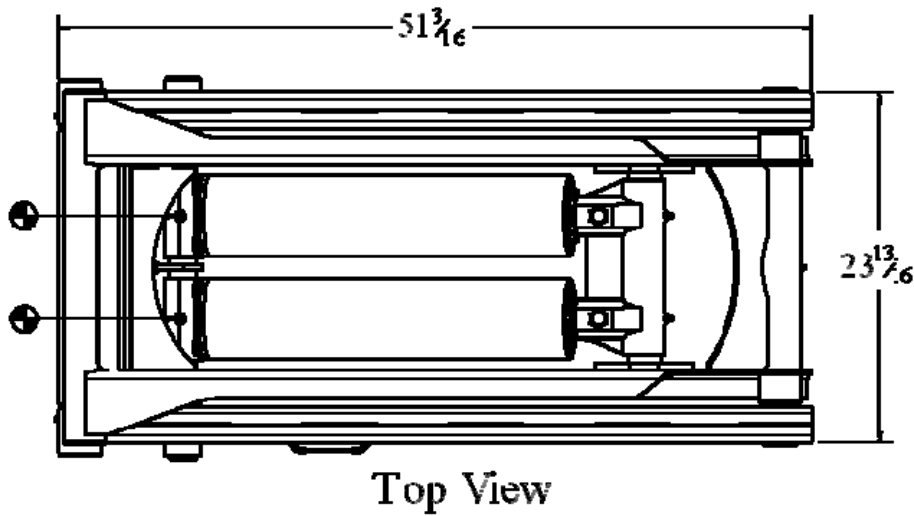

 Grease Fitting Locations

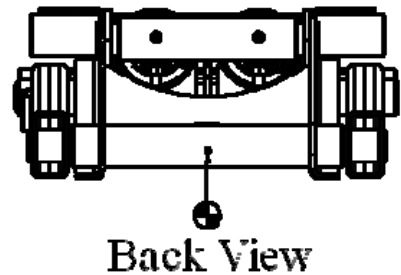
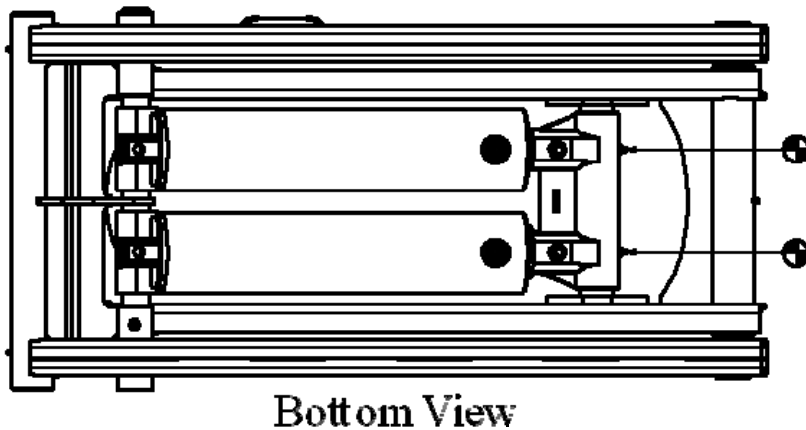

# CHAMPION

Hoist and Equipment  
 Dunn, North Carolina, U.S.A.  
 910 - 897 - 4995  
 Fax 910 - 897 - 6822

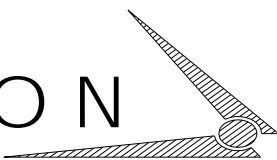

# CS5520T Parts List

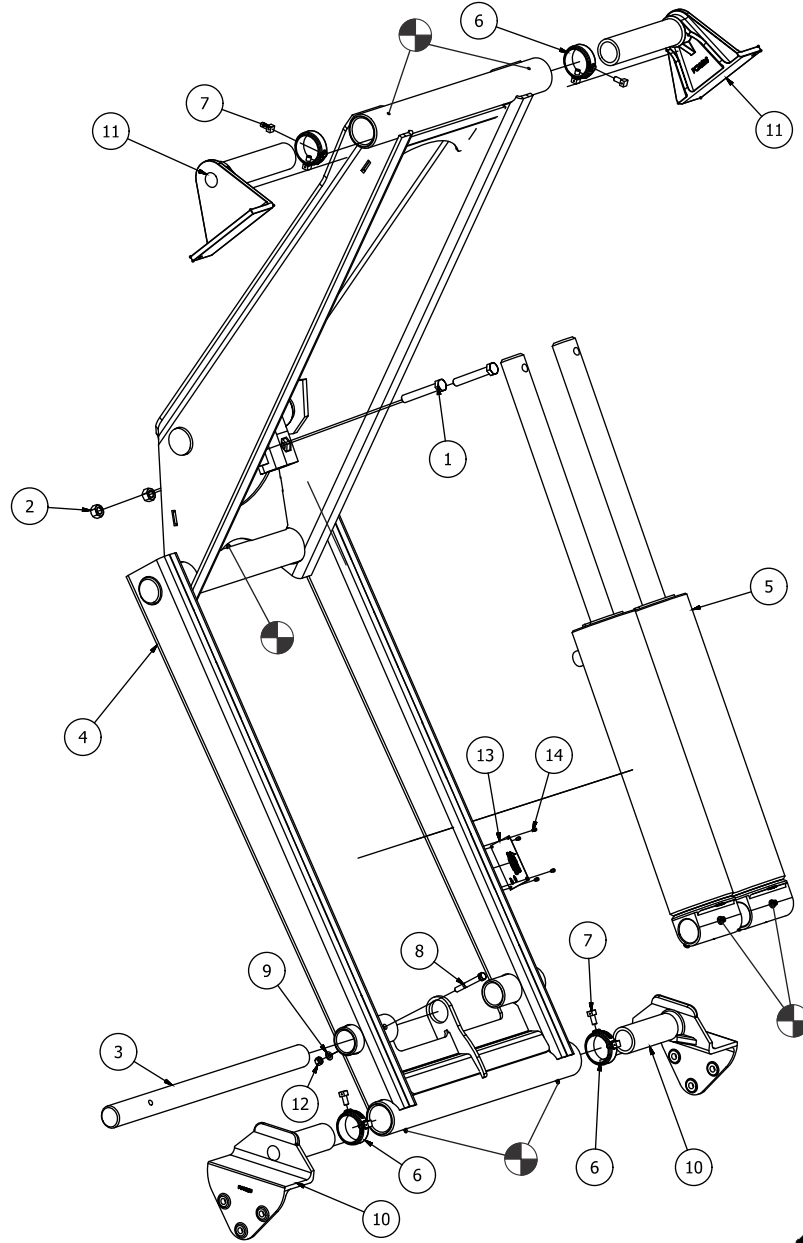

 Grease Fitting Locations

**CS5520T Parts List (refer to engineering drawing A12678)**

Item	Qty.	Part Number	Description
1	2	102-617-L	Hex Cap Screw, 5/8 x, GR 9
2	2	162-10-S	Lock Nut, 1/2"
3	1	SM12058	Cylinder Mount Shaft, 6615/6620/5530/6630/5520T/6620T
4	1	W12336	Weldment, 5520T/6620T Scissor Hoist
5	1	A21359	Assembly 520 Da Cylinder
6	4	PC12157	Set Collar For 2-1/4" Lift Arm
7	8	P34	Set Screw 3/8"- 16 x 3/4" SQHD
8	1	102-213-A1	Hex Bolt, 3/8 x 3 LG. GR 8
9	1	118-3-A1	Lock Washer, 3/8
10	2	PC13285	Lower Lift Arm, 2-1/4"
11	2	PC10626	2-1/4" Upper Lift Arm
12	1	ANSI B18.2.2 - 3/8 - 16	Hex Nut (Inch Series) Hex Nut
13	1	P10200	Champion Serial Plate
14	4	PAAP43	Rivet, 1/8" Cherry Pop

# CS6620T Capacities

<b>CS6620T Hoist Capacity (Tons)</b>			
<b>Body Length (Feet)</b>	<b>Overhang (Inches)</b>	<b>Dump Angle (Degrees) "G" Dimension (Inches)</b>	
		<b>45 Deg.(105.5 Inches)</b>	<b>50 Deg. (95.5 Inches)</b>
10	0	29.40	26.60
	12	36.80	33.30
	18	38.00	38.00
	24	44.40	44.40
11	0	26.70	24.20
	12	32.70	29.60
	18	36.80	33.30
	24	42.00	38.00
12	0	24.50	22.20
	12	29.40	26.60
	18	32.70	29.60
	24	36.80	33.30
13	0	22.50	20.50
	12	26.70	24.20
	18	29.40	26.60
	24	32.70	29.60
14	0	21.00	19.00
	12	24.50	22.20
	18	26.70	24.20
	24	29.40	26.60
15	0	19.60	17.70
	12	22.60	20.50
	18	24.50	22.20
	24	26.70	24.20
16	0	18.40	16.60
	12	21.00	19.00
	18	22.60	20.50
	24	24.50	22.20
17	0	17.30	15.70
	12	19.60	17.70
	18	21.00	19.00
	24	22.60	20.50
18	0	16.30	14.80
	12	18.40	16.60
	18	19.60	17.70
	24	21.00	19.00

# CS6620T Dimensions

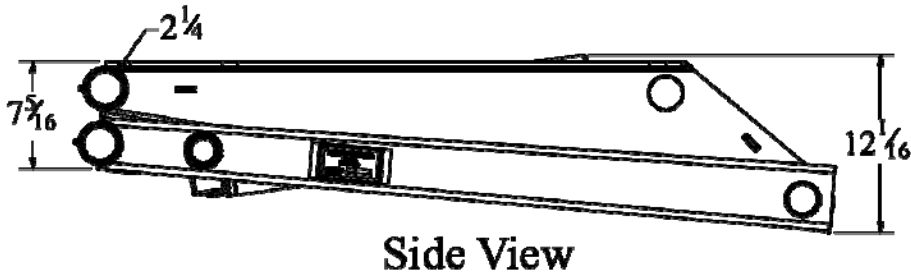
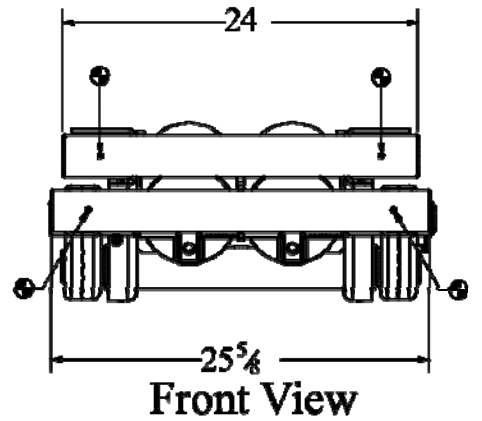
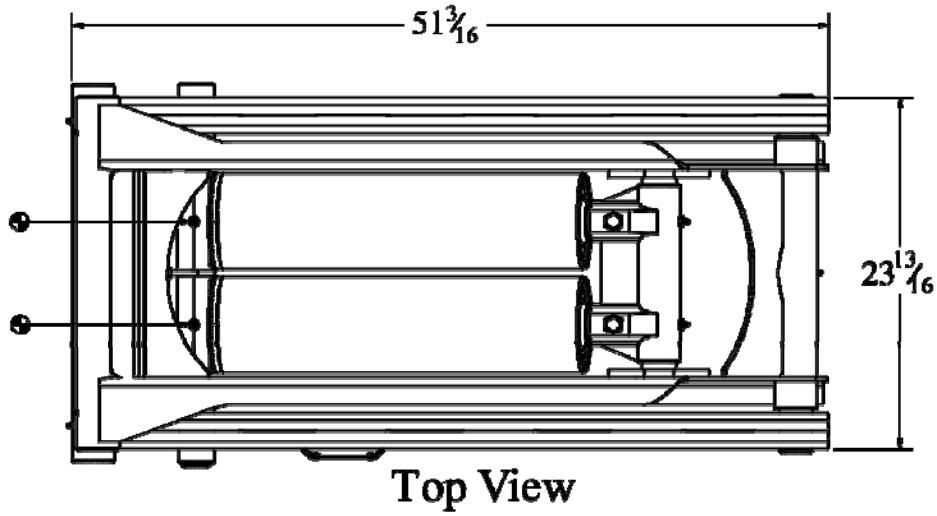

 Grease Fitting Locations

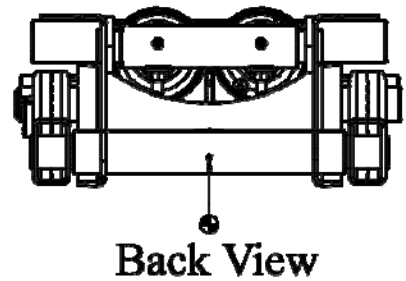
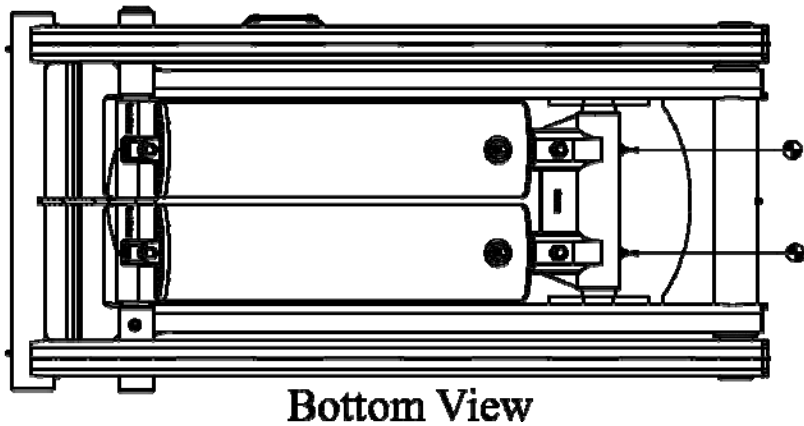

# CHAMPION

Hoist and Equipment

Dunn, North Carolina, U.S.A.

910 - 897 - 4995

Fax 910 - 897 - 6822

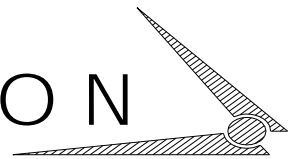

# CS6620T Parts List

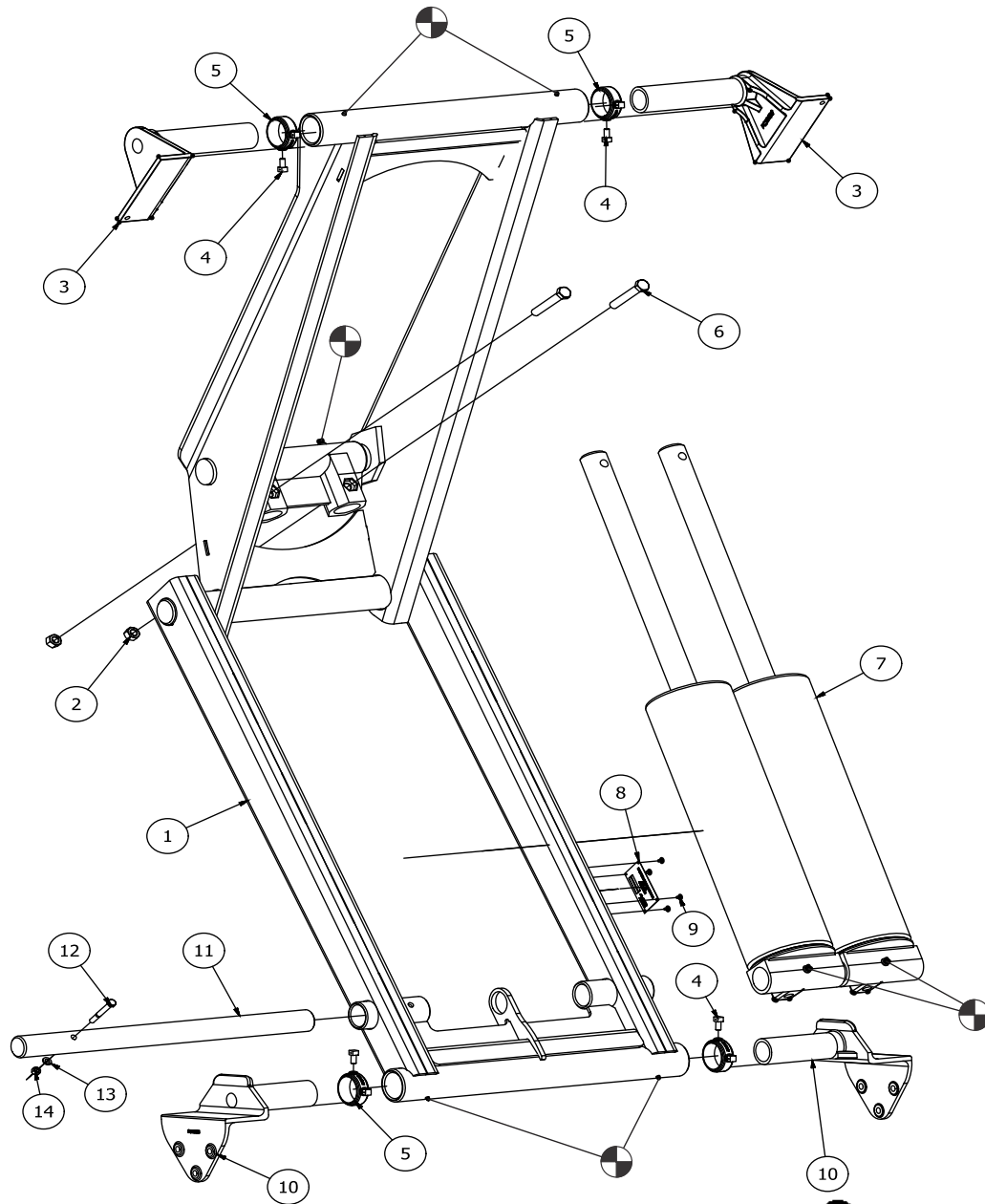

 Grease Fitting Locations

**CS6620T Parts List (refer to engineering drawing A12679)**

Item	Qty.	Part Number	Description
1	1	W12336	Scissor Hoist Weldment, 6620T
2	2	162-10-S	Lock Nut, 1/2"
3	2	PC10626	Upper Lift Arm 2-1/4", 6620T
4	8	P34	Set Screw 3/8"-16 x 3/4" Square Head
5	4	PC12157	Set Collar for 2-1/4" Lift Arm
6	2	102-617-L	Hex Cap Screw, 5/8 x 4, GR 9
7	2	A21328	Cylinder Assembly, 6620T DA
8	1	P10100	Serial Plate
9	4	PAAP43	Rivet, 1/8" Cherry Pop
10	2	PC13285	Lower Lift Arm 2-1/4", 6620T
11	1	SM12058	Cylinder Mount Shaft, 6620T
12	1	102-213-A1	Hex Bolt, 3/8" x 3" LG. GR 8
13	1	118-3-A1	Lock Washer. 3/8"
14	1	116-3-A1	Hex Nut, 3/8" UNC



# CS5520T/CS6620T Rear Hinge Assembly

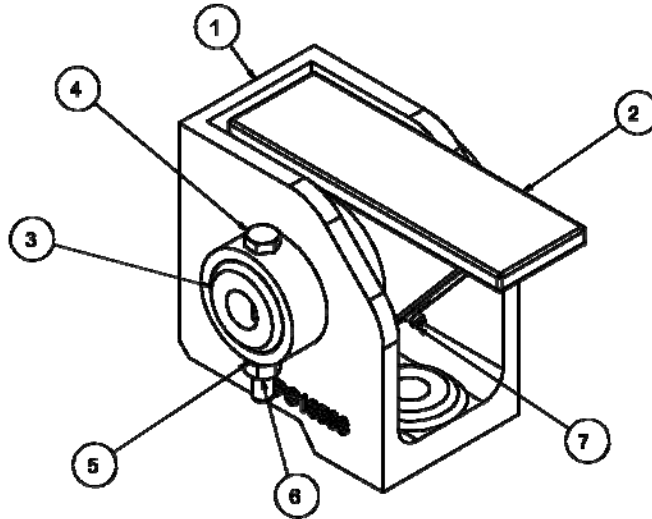

5520T/6620T REAR HINGE ASSEMBLY - PARTS LIST			
Item	Qty.	Part Number	Description
1	1	PC10583	Rear Hinge Block, 1-3/4"
2	1	PC10636	Hinge Flipper, 1-3/4"
3	1	PC10816	1-3/4" Rear Hinge Pin, Short Version
4	1	102-214	Hex Cap Screw, 3/8 X 3 1/4
5	1	118-3-A1	Lock Washer, 3/8
6	1	116-3-A1	Hex Nut, 3/8 UNC
7	1	P800	1/8" Pipe Thread Grease Fitting

# CHAMPION

Hoist and Equipment

Dunn, North Carolina, U.S.A.

910 - 897 - 4995

Fax 910 - 897 - 6822

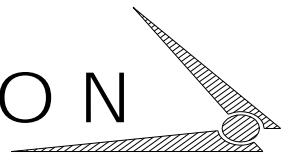

## WARRANTY

Champion Hoist and Equipment warrants these products for a period of 36 months from the date of sale to the customer.

This warranty provides that the equipment shall be free of defective materials and workmanship, or we will replace or repair at our factory, any part that our inspection shows to be defective.

The hydraulic valve, pump, motor, hoses, and other purchased products are not manufactured or warranted by Champion Hoist and Equipment and are therefore covered by the warranties of the manufacturer of these products.

Any part shipped to the factory shall be prepaid, and will be returned collect. Champion Hoist and Equipment does not assume responsibility for shipping, labor or travel expenses.

We reserve the right to make improvements to any of our product without notice or obligation regarding model previously sold.

# CHAMPION

Hoist and Equipment

Dunn, North Carolina, U.S.A.

910 - 897 - 4995

Fax 910 - 897 - 6822

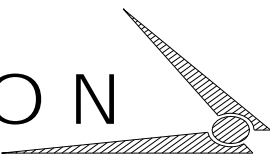

**This Page Intentionally Left Blank**

**C H A M P I O N**

Hoist and Equipment

Dunn, North Carolina, U.S.A.

910 - 897 - 4995

Fax 910 - 897 - 6822

