

CHAMPION

Hoist and Equipment

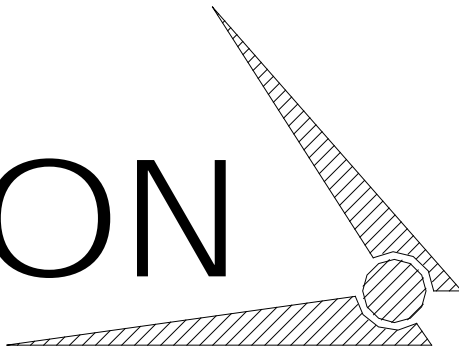

AN AFFILIATE OF

The **Godwin**
 **Group**

200 CHAMPION DRIVE

DUNN, NC. 28334

(910) 897-4995 FAX: (910) 897-7306

UNDERBODY HOIST

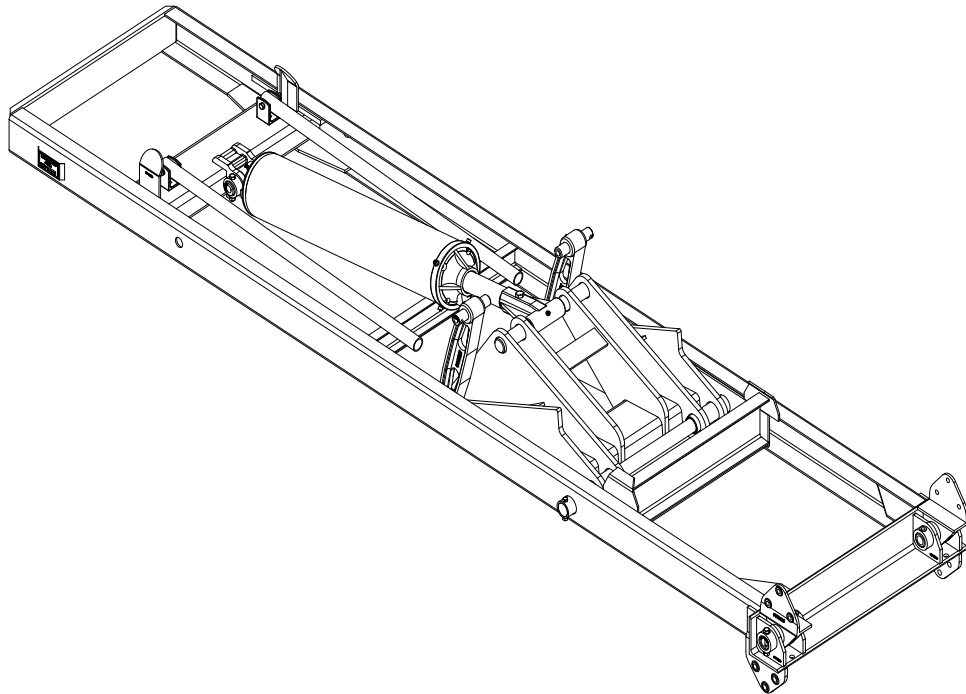

Operation & Installation Manual

CHAMPION HOIST & EQUIPMENT

200 Champion Drive

Dunn, N.C. 28334

800-649-4995

01/2012

UNDERBODY HOIST

Table of Contents

Page 4	Service Information
Page 5-6	Operations and Service Do's & Don'ts (SAFTY INFORMATION)
Page 7	Hoist Operation Instructions
Page 8-9	Champion Subframe Hoist Installation Procedures
Page 10	Subframe Installation Detail
Page 11	Hydraulic Reservoir Tank Installation & Lubrication Instructions
Page 12	Detailed Instructions to Reverse Rotation on a C102 Pump
Page 13	SP4 Valve & Valve Bracket/Control Handle Assembly
Page 14	Safety Prop Cup Installation
Page 15	Hydraulic Plumbing Diagram
Page 16	Hydraulic Plumbing Diagram w/ SP-4 Valve
Page 17-38	Parts, Performance, and Layout Dimensions



CHAMPION HOIST AND EQUIPMENT

200 CHAMPION DRIVE
DUNN, N.C. 28334

Phone# (800) -649-4995

Phone# (910) -897-4995

fax# (910) -897-7306

when calling, specify (parts) - (service) - (sales)
have the following information on hand for
faster service, body model # & Serial #
hoist model # & serial #
year, make, type of truck.

this information is provided as indicated

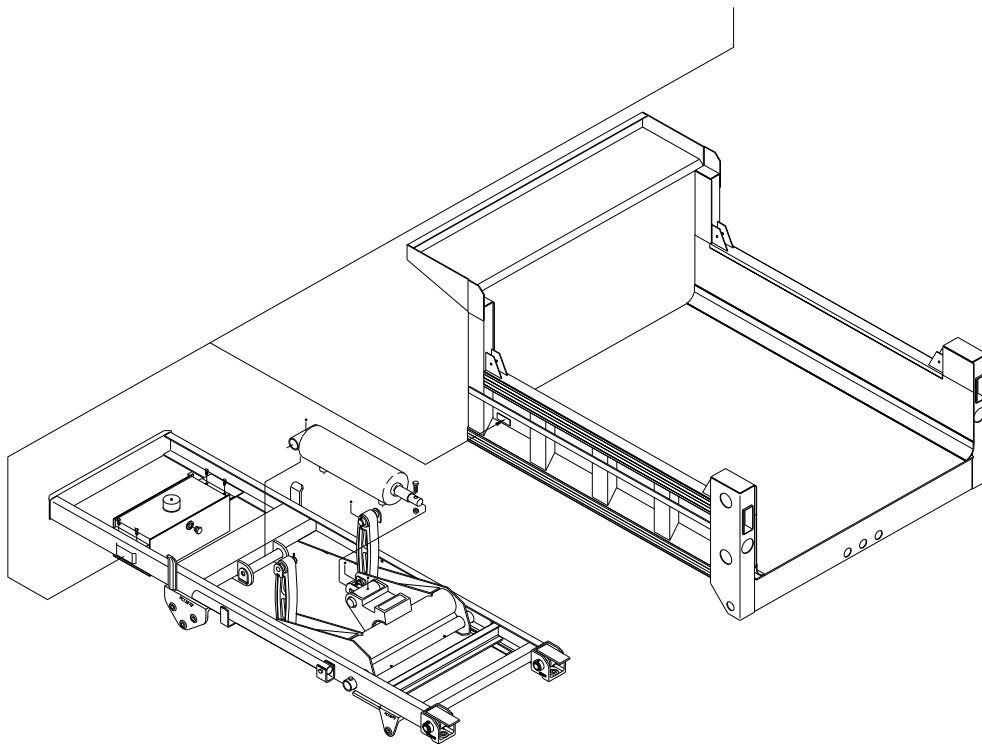

Operations and Service Manual

Do not operate this equipment without fully reading and understanding this manual.

Do not allow unauthorized personnel to operate this equipment.

Do not go underneath a loaded raised bed under ANY circumstances.

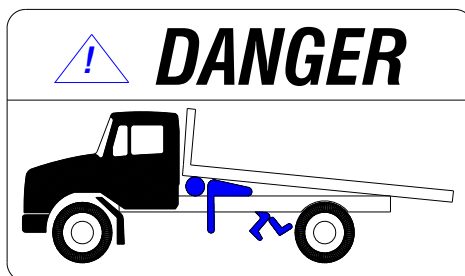

Do not go underneath an unloaded raised bed unless the safety props are properly positioned.

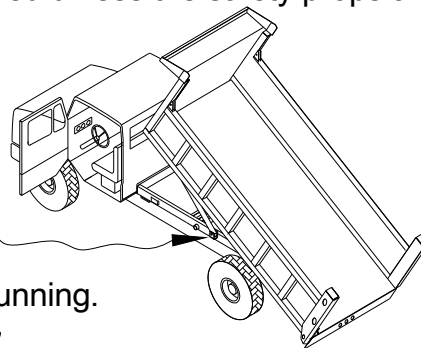

Do not go underneath a truck with engine running.

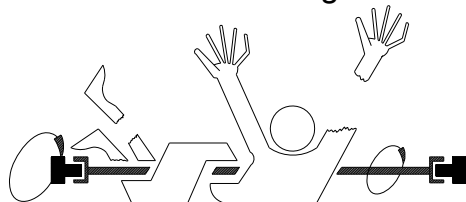

Do not allow controls and area around them to become cluttered with tools, cans, etc.

Do not use hands or other body parts to check for hydraulic leaks.

Do not leave truck unattended with bed raised.

Do not allow personnel to ride in or on the bed.

Do not load the equipment beyond the GVW rating of the vehicle or the hoist rating.

Do not operate the hoist on an unlevel or soft surface.

Do not operate the hoist **UNDER POWER LINES!!**

Do not raise the hoist when vehicle is in motion.

Do not move a vehicle with a raised hoist.

Be sure to.....

- * Follow all Federal, State, Local regulations pertaining to this equipment.
- * Keep unit properly maintained and serviced.
- * Understand and follow all safety decals and keep them in good condition.
- * Check hydraulic oil level weekly.
 - * For PTO driven pumps use HD 32 hydraulic oil.
 - * For electric driven pumps use ATF, automatic transmission fluid.
- * Add correct hydraulic oil to reservoir as needed.
- * Use EP-3 grease for all grease fittings.
- * Lubricate hoist and rear hinge assembly every 90 to 180 days depending on useage. (See MP50077)
- * Check all bolts, welds, electrical connections frequently.

When calling for Parts/Service Be Sure To Have....

Flatbed: model number _____
serial number _____
Serial Plate Location _____

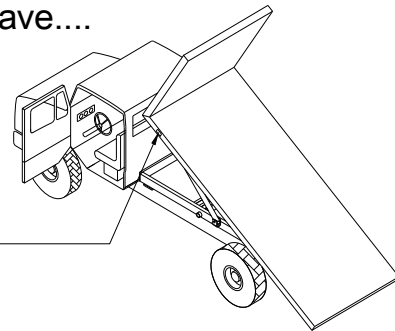

Hoist: model number _____
serial number _____
Serial Plate Location _____

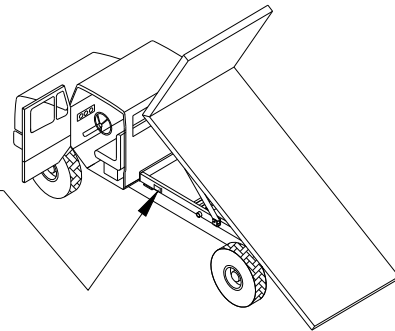

HOIST OPERATION

To Operate Hoist:

- (1) Engage PTO per PTO operation instructions.
- (2) The pump/hoist control should be in the neutral or “hold” position.
- (3) For a manual control - pull to raise, push to lower.
NOTE: Manual push/pull controls require a 1/2 inch mounting hole.
- (4) When bed raises to desired height, push the pump/hoist controls to the center neutral or “hold” position. This will stop bed movement up or down.
- (5) To lower bed - push pump/hoist control.
- (6) Disengage PTO.

INSTALLATION INSTRUCTIONS
816SFDAP & 820SFDAP
REFER TO MP50074

- STEP #1 SET SUB FRAME ON CHASSIS 4" FROM CAB.
(NOTE: MAKE SURE THERE ARE NO OBSTRUCTIONS (MUFFLER ETC.)
- STEP #2 DRILL (8) 1/2" HOLES THRU CHASSIS AND INSTALL HARDWARE.
(EACH SIDE)
- STEP #3 DRILL (2) 5/8" HOLES THRU CHASSIS AND INSTALL 5/8" x 2-1/2" BOLT.
(EACH SIDE)
- STEP #4 REMOVE EXCESS CHASSIS.
- STEP #5 INSTALL PUMP CABLE ASSEMBLY IN CAB OF TRUCK. THIS REQUIRES A
1/2" HOLE DRILLED THRU CAB FLOOR. (NOTE: CONTROL MUST MOUNTED
IN FLOOR DUE TO CABLE LENGTH)
- STEP #6 MOUNT HYDRAULIC PUMP TO PTO. BEFORE MOUNTING, CHECK ROTA-
TION OF PUMP. IF PUMP HAS A ROTATION THAT NEEDS TO BE REVERSED
SEE MP50078 - PROCEDURES TO REVERSE C102 PUMPS ROTATION. IF
APPLICATION CALLS FOR A P22 PUMP SEE NOTE ON PD40030 FOR
FURTHER INSTRUCTIONS.
- STEP #7 INSTALL RESERVOIR TANK IN FRONT OF LOWER BUNK FOR A C102 PUMP
APPLICATION AS INDICATED ON MP50077.
FOR A P22 PUMP APPLICATION, TWO THINGS NEED TO BE CONSIDERED:
#1 - REQUIRES A SP4 VALVE & VALVE MOUNTING BRACKET & A CABLE
SUPPORT BRACKET. (SEE MP50079)
#2 - RESERVOIR MOUNTING. SP4 BRACKET IS TO BE MOUNTED IN SUCH A
WAY THAT THE PORTS ARE ACCESSIBLE AND THE CABLE CONTROLS
OPERATE FREELY. AFTER DETERMINING WHERE THE SP4 VALVE
MOUNTING BRACKET WILL BE MOUNTED, INSTALL RESERVOIR.
(SEE MP50077)
- STEP #8 PLUMB HYDRAULICS PER PLUMBING DIAGRAM:
PD40029 - SINGLE ACTING CYLINDERS W/ C102 PUMP
PD40030 - DOUBLE ACTING CYCILNDERS W/ P22 PUMP
- STEP #9 AFTER HYDRAULIC CONNECTIONS ARE COMPLETED AND CABLE
ASSEMBLY INSTALLED, FILL RESERVOIR WITH OIL.

INSTALLATION INSTRUCTIONS CONTINUED

- STEP #10 SET BODY. THERE ARE 2 METHODS.
- #1 FOR A SINGLE ACTING ASSEMBLY - WITH HOIST RAISED SUSPEND BODY OVER SUBFRAME A MINIMUM OF 4" AWAY FROM CAB, AND LOWER BODY DOWN LOW ENOUGH TO INSTALL UPPER LIFT ARM PINS TO BODYS UPPER BUNK. (SEE MP50077 ITEM 1) AFTER INSTALLATION OF LIFT ARM PINS AND COTTER PINS, LOWER HOIST AND BODY ONTO CHASSIS MAKING SURE CYLINDER IS FULLY RETRACTED. BODY SHOULD BE EVEN WITH FRONT SUBFRAME RAILS. WELD REAR HINGE FLIPPERS SECURELY TO BODY.
- #2 FOR A DOUBLE ACTING ASSEMBLY - RAISE HOIST AND SUSPEND BODY OVER SUBFRAME A MINIMUM OF 4" AWAY FROM CAB, AND LOWER BODY DOWN LOW ENOUGH TO INSTALL UPPER LIFT ARM PINS TO BODYS UPPER BUNK. (SEE MP50077 ITEM 1) AFTER INSTALLATION OF LIFT ARM PINS AND COTTER PINS, WHILE LOWERING BODY ONTO CHASSIS AND AT THE SAME TIME USING HYDRAULIC POWER, BOTTOM OUT CYLINDER TO PULL SLACK OUT OF HOIST. SECURELY WELD REAR HINGE FLIPPERS TO BODY.
- CAUTION - IF SLACK IS NOT REMOVED DAMAGE TO HOIST/BODY COULD OCCUR!!!**
- STEP #11 INSTALL SAFETY PROP CUPS ON BODY IN SUCH A MANNER THAT THE PROP IS ANGLED SLIGHTLY TO THE REAR. (SEE MP50080)
- STEP #12 REINSPECT ALL WELDS, CHECK THAT ALL HARDWARE IS SECURE, AND PLUMBING CONNECTION FOR LEAKS. (REPAIR AS NECESSARY)
- STEP #13 GREASE ALL PIVOT POINTS AND GREASE FITTINGS. (SEE MP50077)

NOTE: NEVER WORK ON A RAISED EMPTY BODY WITHOUT SAFETY PROPS IN PLACE!!!

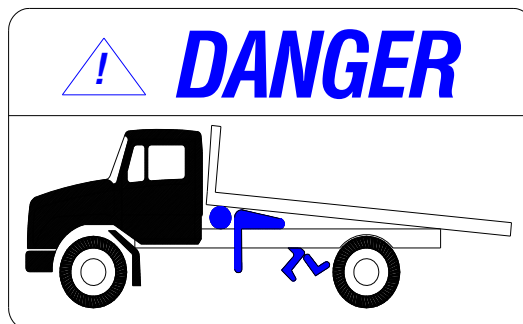

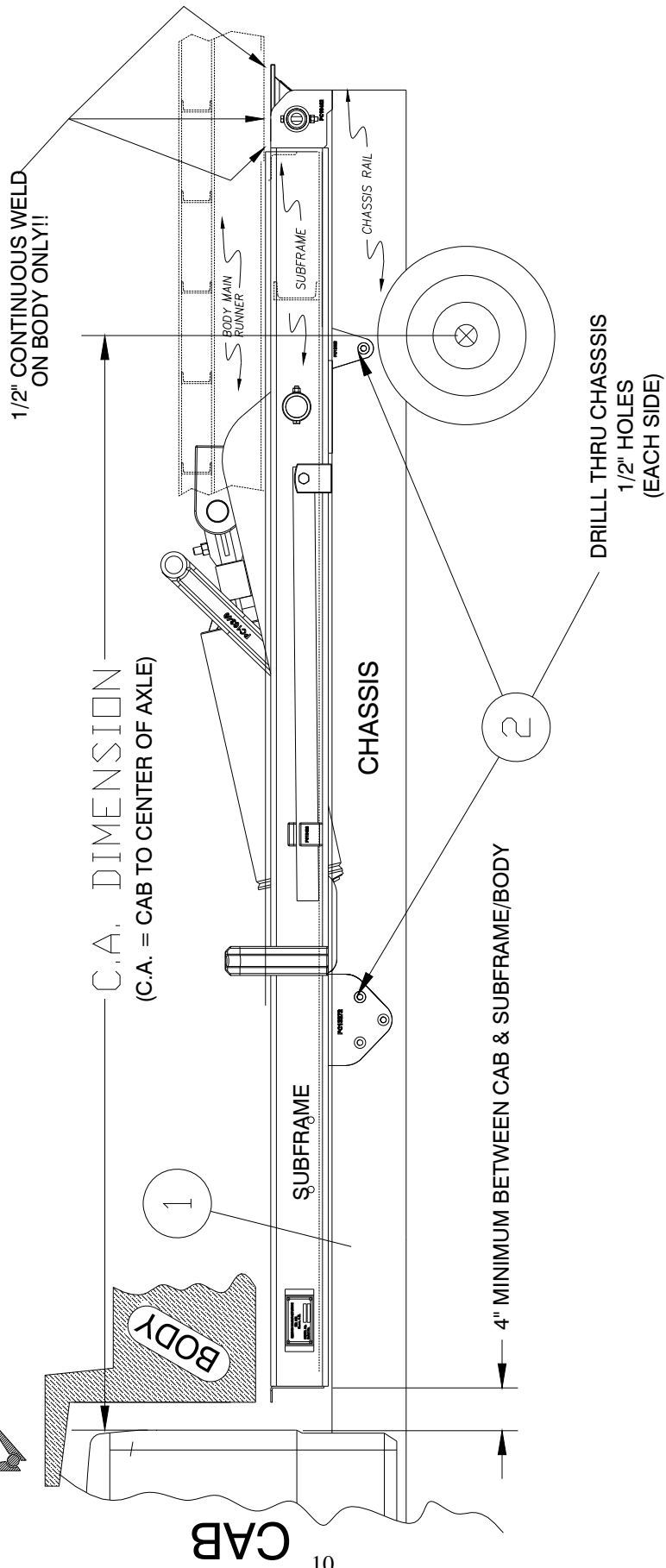

C.A. DIMENSIONS (CAB TO CENTER OF AXLE)		
C.A. DIMENSION	72"	84"
BODY LENGTH	9'	10'

LUBRICATION INSTRUCTIONS AND HYDRAULIC RESERVOIR INSTALLATION

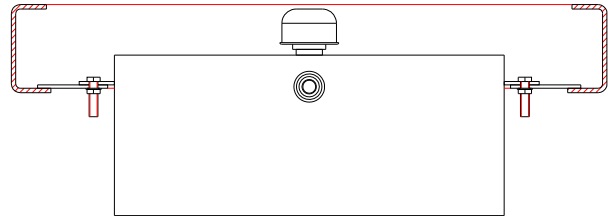

SECTION A - A

NOTE: WELD BRACKET TO SUBFRAME
AT DESIRED LOCATION. (EACH SIDE)

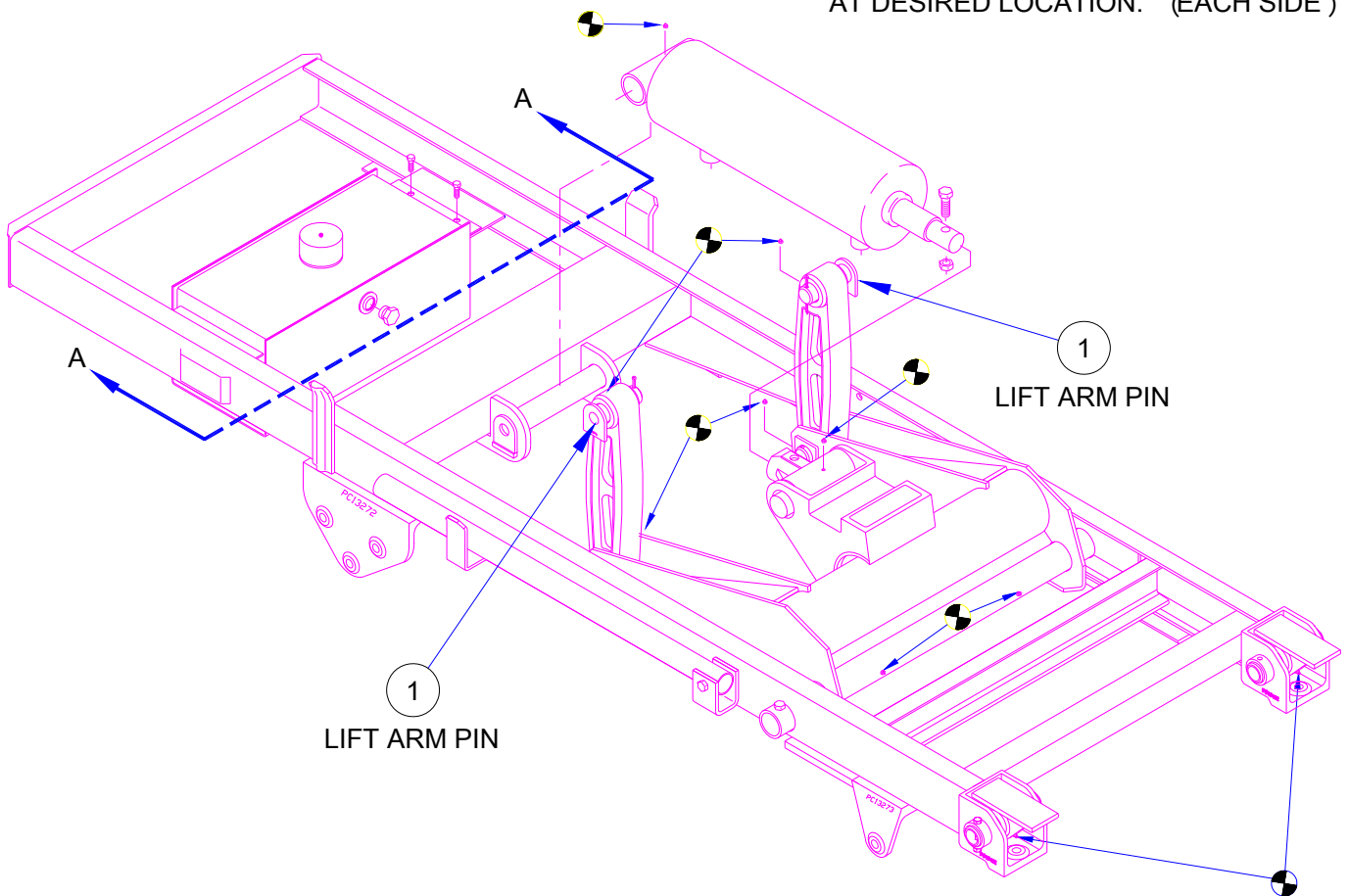

 - INDICATES GREASE FITTING LOCATIONS THAT MUST BE LUBRICATED
DEPENDING ON USAGE, LOAD, ENVIRONMENT AND CLIMATE.
LUBRICATE ALL PIVOT POINTS USING EP-2 CHASSIS GREASE
OR EQUAL.

* Grease hoist and rear hinge assembly each time truck is serviced.

INSTRUCTIONS TO REVERSE C102 PUMP ROTATION

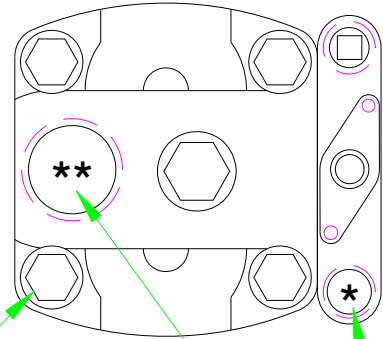
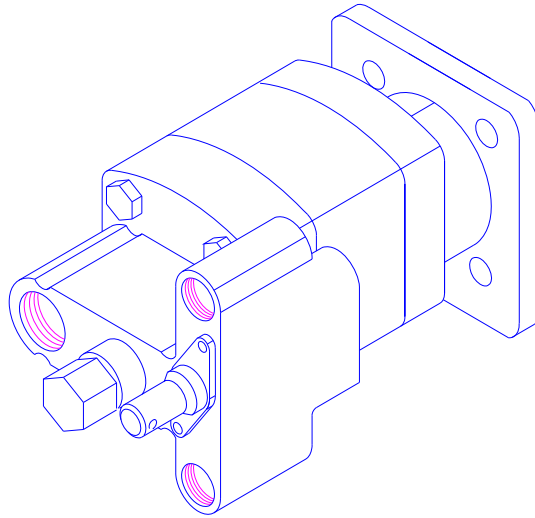

STEP #1 SECURELY MOUNT PUMP FLANGE IN VISE
SHAFT DOWN!

STEP #2 REMOVE (4) HEX BOLTS, WASHERS.

** SUCTION PORT

STEP #3 LIFT OFF VALVE AND CENTER SECTION OF
PUMP LEAVING FRONT COVER AND GEARS
IN PLACE, AND ROTATE 180°.

* CYLINDER PORT

STEP #4 LOWER CENTER SECTION AND VALVE ONTO
FRONT COVER AND GEARS BEING CAREFUL
NOT TO DISTURB POCKET SEALS IN TRUST
PLATES. (IF NEEDED GLUE IN WITH CHASSIS
GREASE) .

STEP #5 REINSTALL BOLTS AND WASHERS AND EVENLY
TORQUE ASSEMBLY BOLTS TO 200 FOOT LBS.

SP4 VALVE CONTROL HANDLE ASSEMBLY

REMOTE VALVE for DA APPLICATION

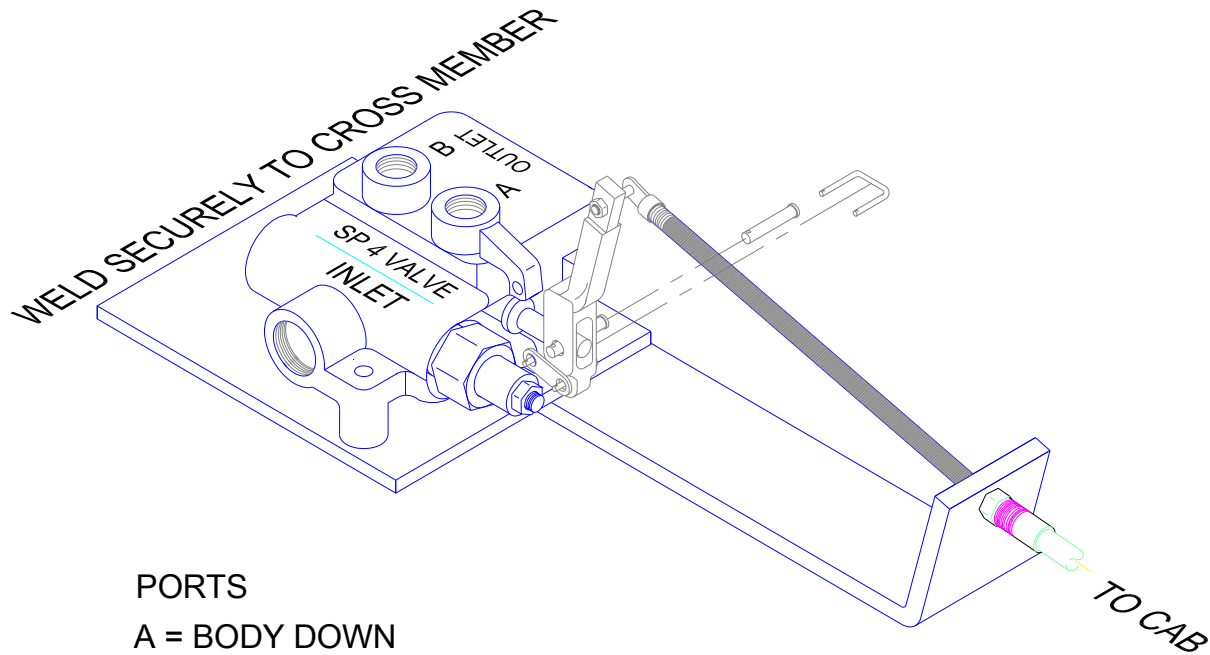

PORTS

A = BODY DOWN

B = BODY UP

INLET = DISCHARGE FROM PUMP

OUTLET = RETURN TO RESERVOIR

HYDRAULIC CONTROL CABLE FOR STANDARD CABS-R38LLR 8' LONG, STANDARD.
OTHER LENGTHS AVAILABLE

SAFETY PROP CUP INSTALLATION

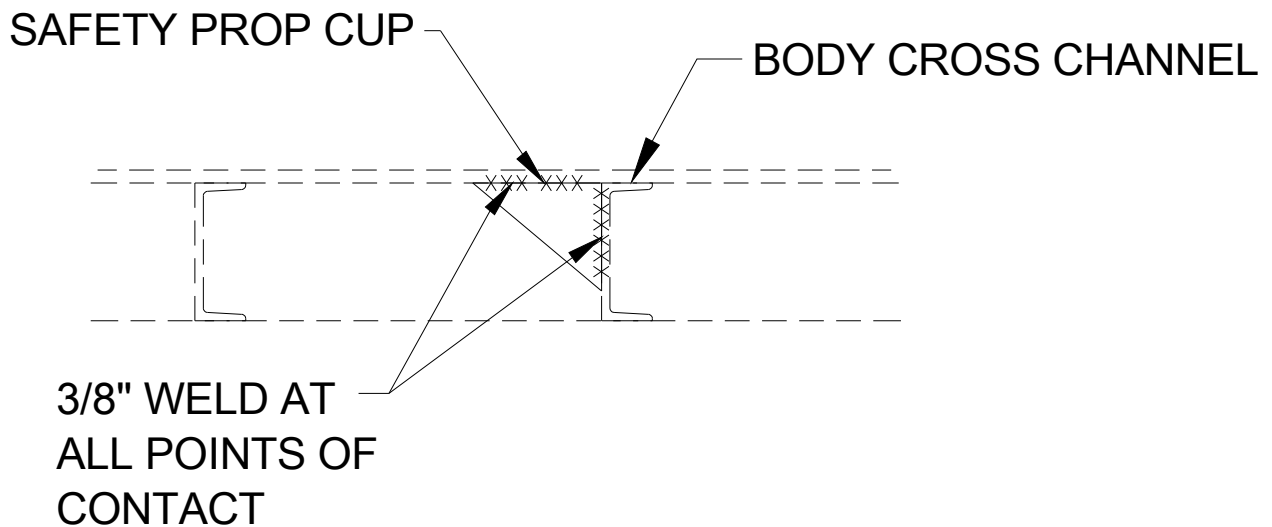

LOCATE SAFETY PROP CUPS ON BODY MAIN RUNNER SO THAT THE SAFETY PROP IS ANGLED SLIGHTLY TO THE REAR. ALSO, BE SURE CUPS ARE SUPPORTED BY A BODY CROSS CHANNEL.

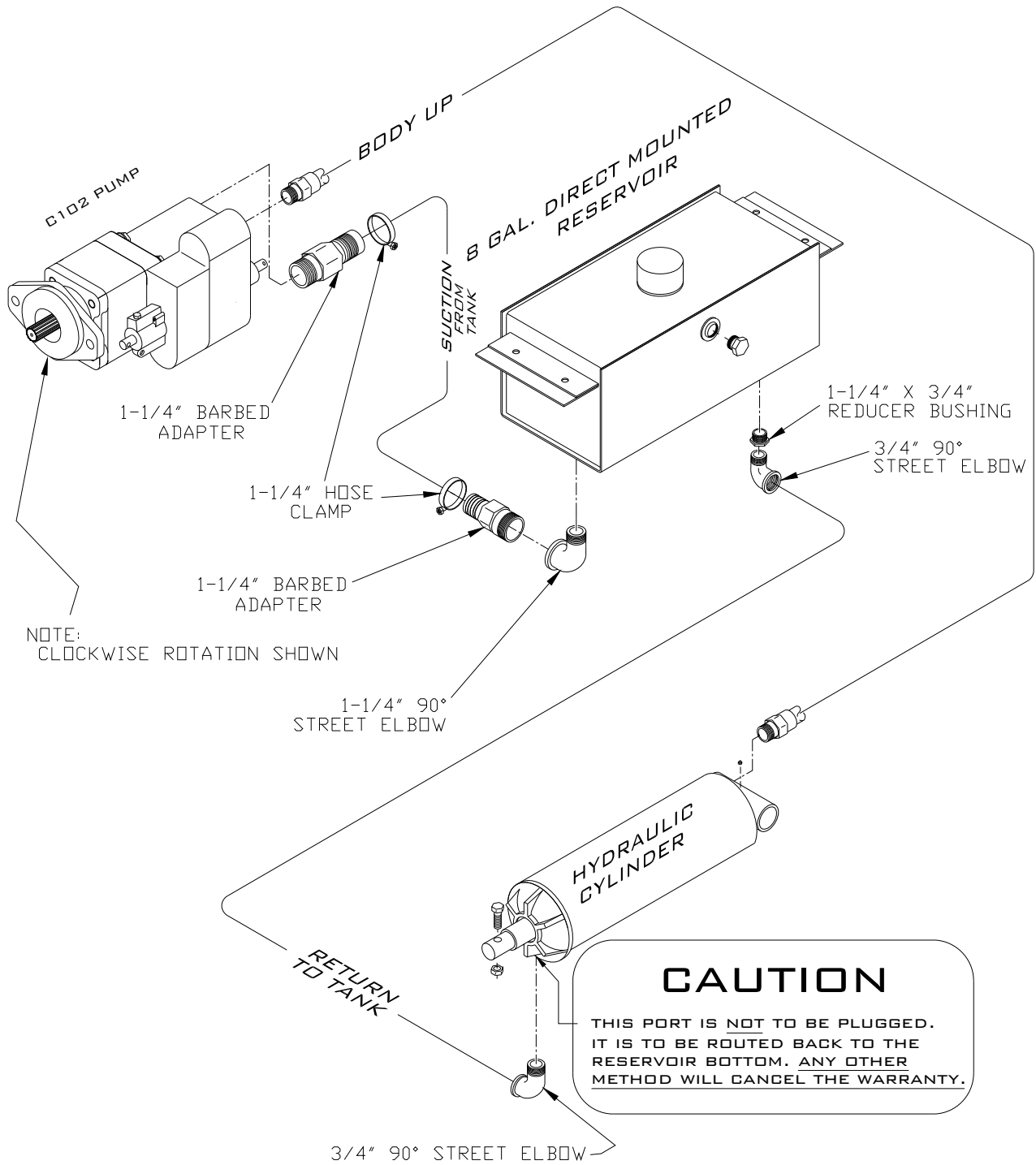

NOTE: RESERVOIR TANK HAS (2) 1-1/4" FLANGES ON THE BOTTOM
EITHER OF THE 2 COULD BE USED FOR SUCTION/RETURN TO TANK.

HYDRAULIC PLUMB DIAGRAM-DA

HYDRAULIC PLUMB DIAGRAM-DA

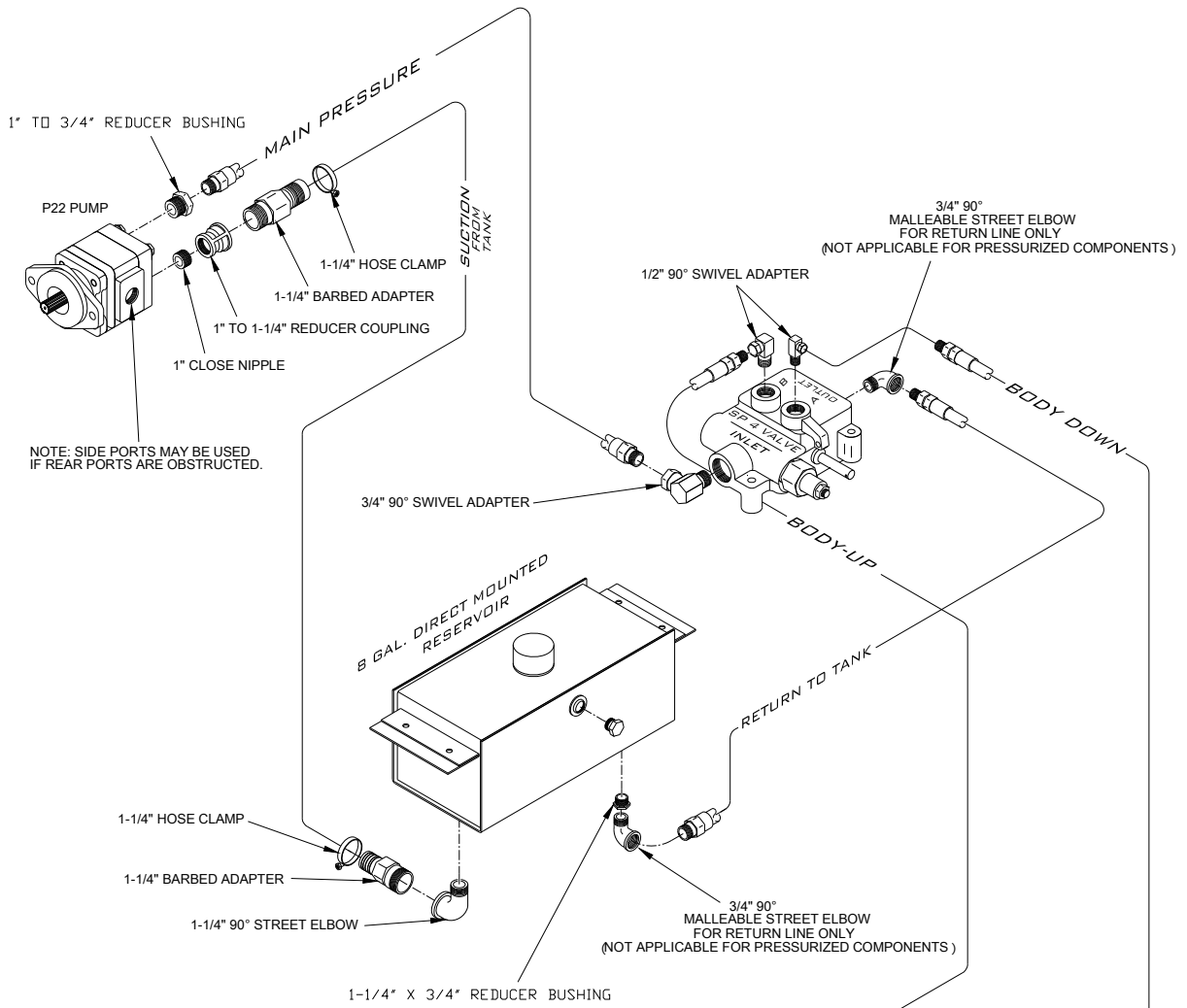

NOTE: RESERVOIR TANK HAS (2) 1-1/4" FLANGES ON THE BOTTOM EITHER OF THE 2 COULD BE USED FOR SUCTION/RETURN TO TANK.

NOTE: WHEN PLUMBING PUMP, BE SURE TO USE THE PROPER PORT. IF YOU ARE NOT SURE WHICH PORT IS SUCTION & WHICH MAIN PRESSURE, LEAVE SHIPPING PLUGS IN PORTS AND OPERATE PUMP NO LONGER THAN 3 SECONDS. THIS WILL POP OUT THE MAIN PRESSURE SHIPPING PLUG. BE SURE IT RUNS NO LONGER THAN 3 SECONDS OR PERMANENT DAMAGE TO THE PUMP MAY OCCUR!!

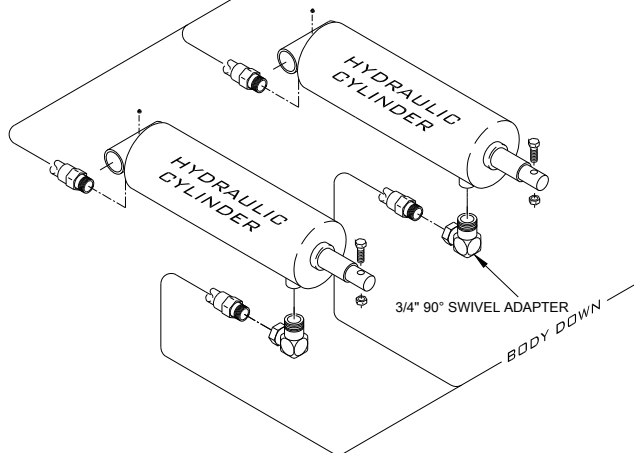

HYDRAULIC PLUMB DIAGRAM-DA

CHAMPION HOIST MODEL: 524DM, 624DM

STANDARD SUBFRAME LENGTHS (FT):

8, 9

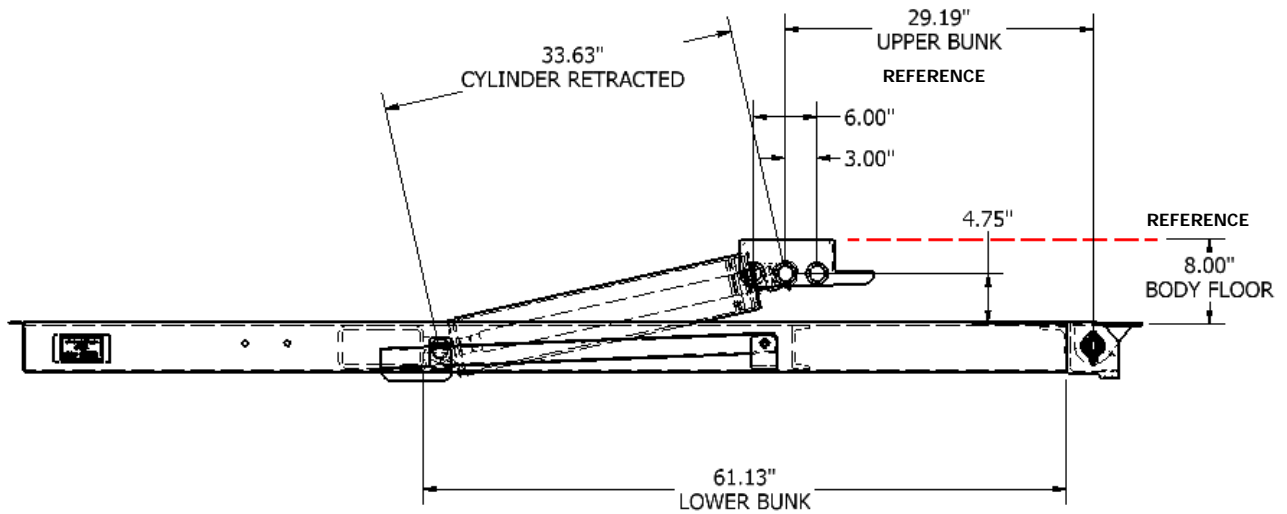
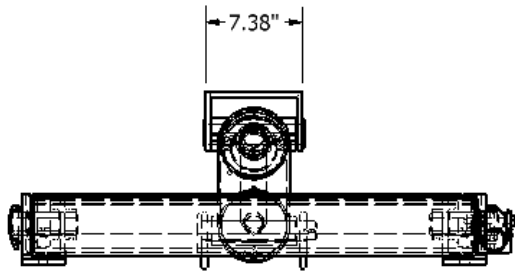

DESIGNED FOR TRUCKS WITH 10,000 TO 14,500 GVW

CHAMPION

Hoist and Equipment

Dunn, North Carolina, U.S.A.

910 - 897 - 4995

Fax 910 - 897 - 6822

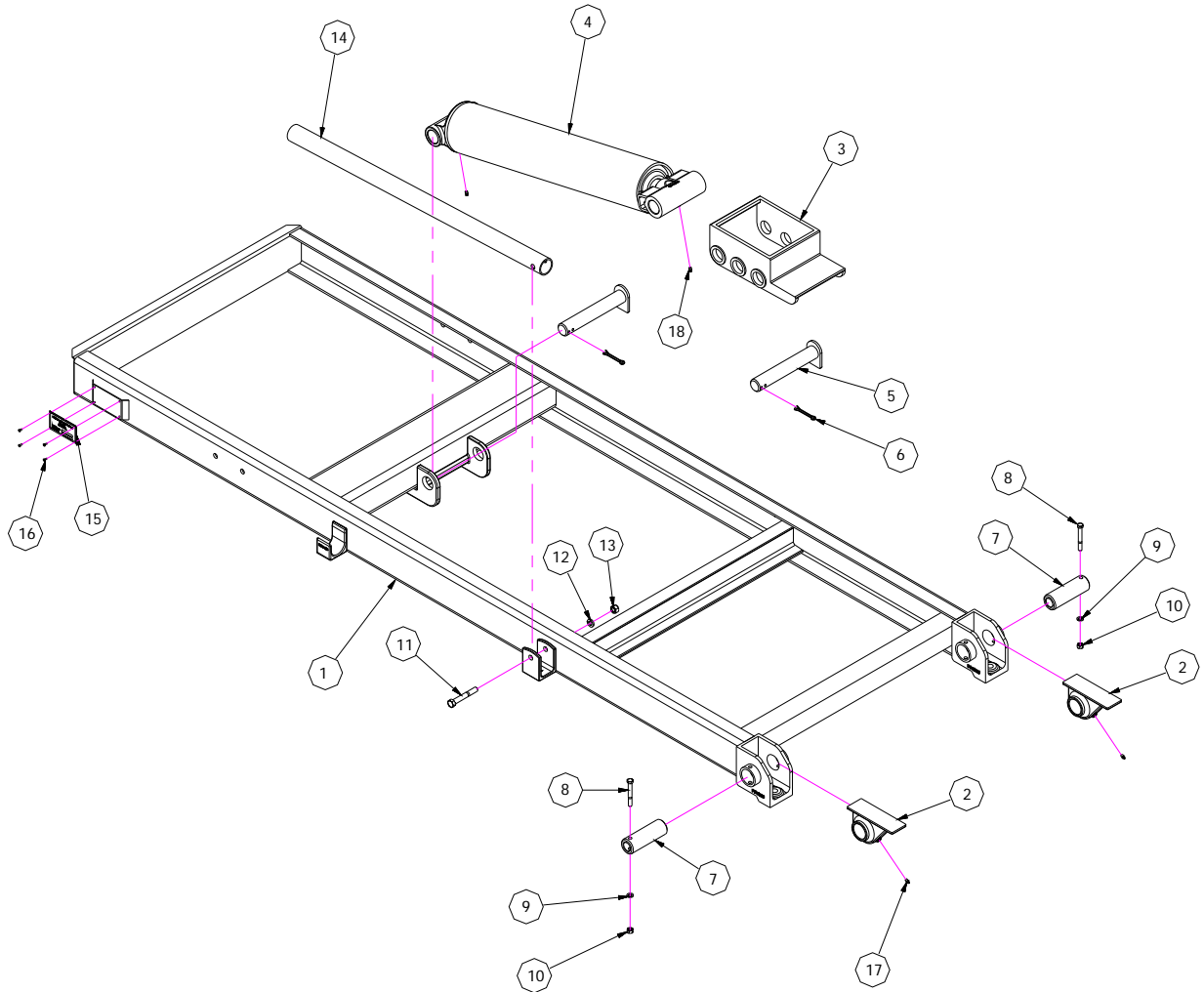

Parts List			
ITEM	QTY	PART NUMBER	DESCRIPTION
1	1	W13436	WELDMENT SUBFRAME
2	2	PC10636	REAR HINGE BLOCK
3	1	PC10749	UPPER LIFT POINT
4	1	524CYLINDER	CYLINDER, UNDERBODY
5	2	PC10560	PIN, LOWER AND UPPER BUNK
6	2	125-260	COTTER PIN, 1/4 X 3
7	2	PC10816	PIN, REAR HINGE
8	2	102-213-A1	HEX BOLT, 3/8-16 UNC X 3
9	2	118-3-A1	LOCK WASHER, 3/8
10	1	116-3-A1	HEX HUT, 3/8
11	1	102-415-A1	HEX BOLT, 1/2-13 UNC X 3 1/2 GR8
12	1	118-5-A1	LOCK WASHER, 1/2
13	1	116-5-A1	HEX NUT, 1/2-13 UNC
14	1	SM13033	SAFETY STAND
15	1	P10100	SERIAL PLATE
16	1	PAAP43	RIVET
17	2	PT7608	GREASE FITTING
18	2	P853	GREASE FITTING

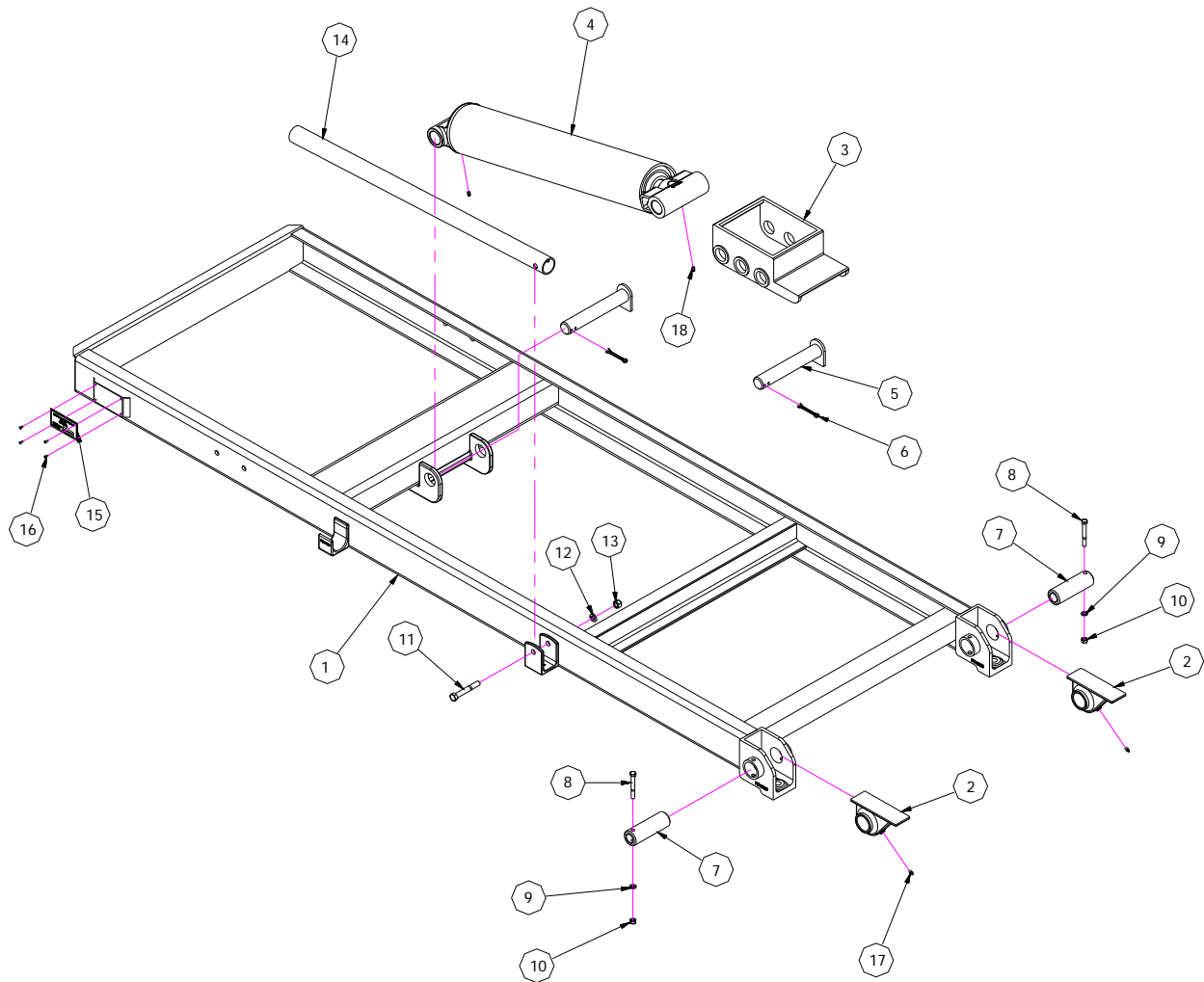

Parts List			
ITEM	QTY	PART NUMBER	DESCRIPTION
1	1	W13436	WELDMNT SUBFRAME
2	2	PC10636	REAR HINGE BLOCK
3	1	PC10749	UPPER LIFT POINT
4	1	624CYLINDER	CYLINDER, UNDERBODY
5	2	PC10560	PIN, LOWER AND UPPER BUNK
6	2	125-260	COTTER PIN, 1/4 X 3
7	2	PC10816	PIN, REAR HINGE
8	2	102-213-A1	HEX BOLT, 3/8-16 UNC X 3
9	2	118-3-A1	LOCK WASHER, 3/8
10	1	116-3-A1	HEX HUT, 3/8
11	1	102-415-A1	HEX BOLT, 1/2-13 UNC X 3 1/2 GR8
12	1	118-5-A1	LOCK WASHER, 1/2
13	1	116-5-A1	HEX NUT, 1/2-13 UNC
14	1	SM13033	SAFETY STAND
15	1	P10100	SERIAL PLATE
16	1	PAAP43	RIVET
17	2	PT7608	GREASE FITTING
18	2	P853	GREASE FITTING

CHAMPION HOIST MODEL: 5530DM

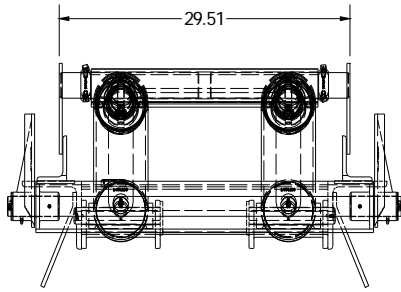

STANDARD SUBFRAME LENGTHS (FT):
12,13,14

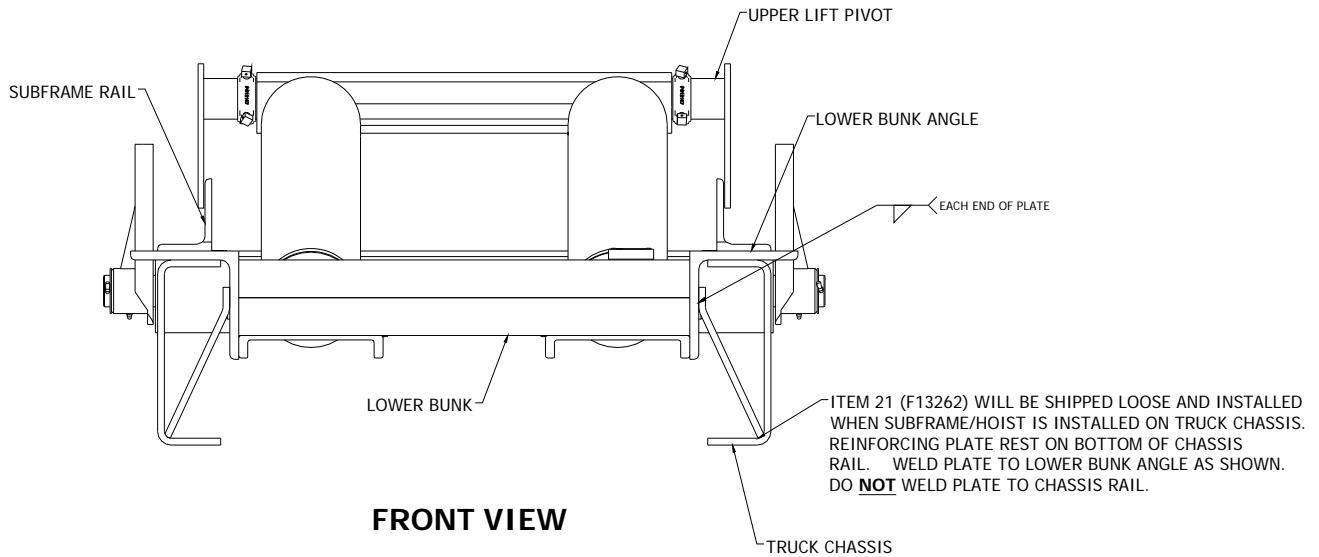
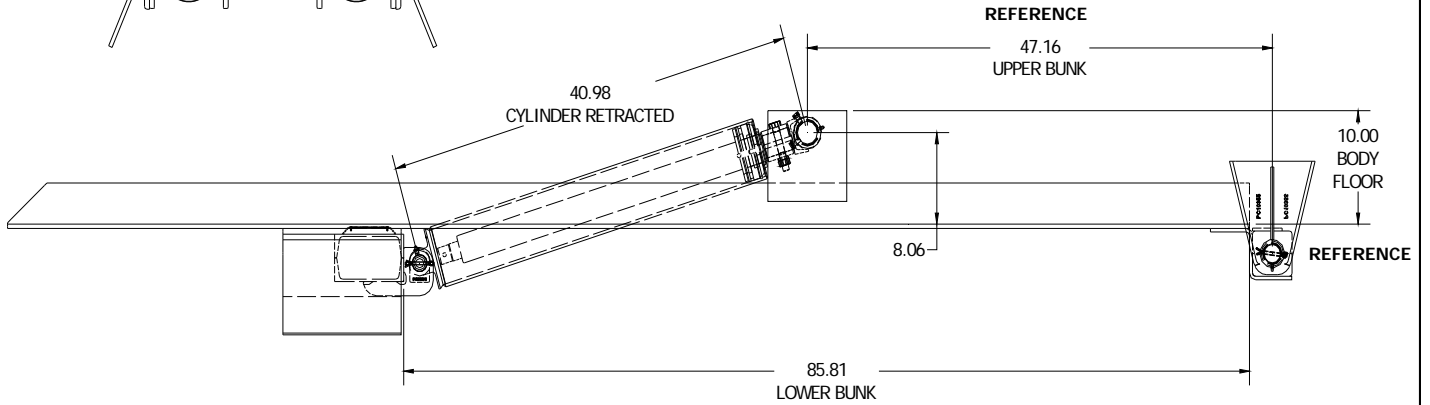

DESIGNED FOR TRUCKS WITH 24,000 TO 33,000 GVW

CHAMPION

Hoist and Equipment

Dunn, North Carolin, U.S.A.

910 - 897 - 4995

Fax 910 - 897 - 6822

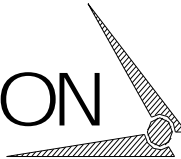

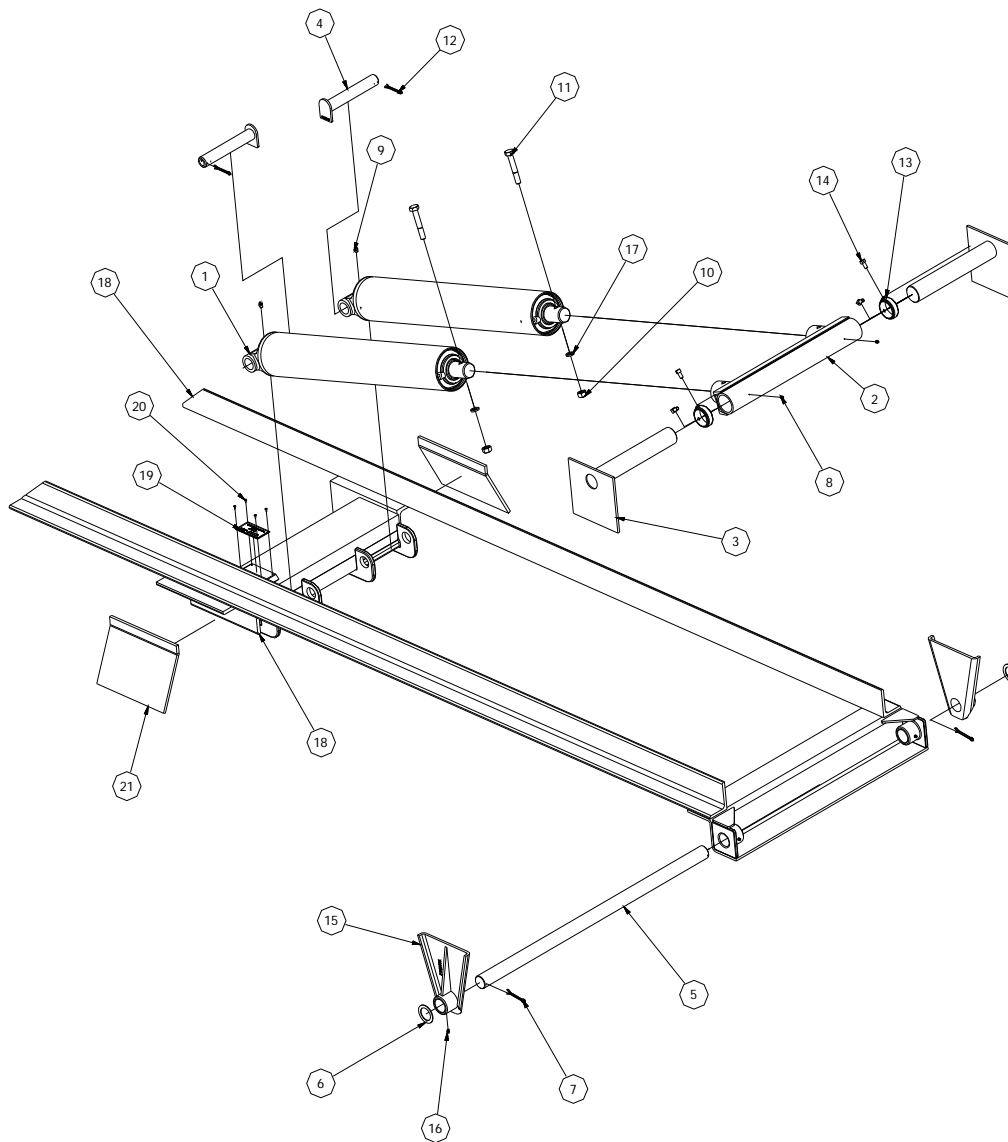

PARTS LIST

ITEM	QTY	PART NUMBER	DESCRIPTION
1	2	5530 DA	5530 DA CYLINDER ASSEMBLY
2	1	W13149	DOUBLE TEE WLD. - 5530
3	2	W13152	UPPER TEE WILD. - 5530 SF
4	2	PC10560	5530 DM LOWER PIN
5	1	SM20065	REAR HINGE SHAFT
6	2	122-15	WASHER, 2"
7	2	125-259	Pin - Cotter (1/4" X 2-1/2")
8	4	P515	FITTING, GREASE (1/4 DRIVE)
9	2	P800	FITTING, GREASE (1/4 NPT)
10	2	116-7-A1	Hex Thick Nut
11	2	102-617-A1	Heavy Hex Bolt
12	2	125-258	Pin - Cotter (1/4" X 2-1/4")
13	2	PC12157	SET COLLOR FOR UPPER LIFT ARM 2-1/4"
14	4	P34	SET SCREW
15	2	PC10355	2" REAR HINGE BLOCK, CASTING LG. CONTRACTOR BODY
16	2	PT7608	GREESE FITTING
17	2	118-7-A1	Helical Spring Lock Washers
18	1	W13439	WELDMENT - SUBFRAME 5530 DM
19	1	P10100	PLATE, SERIAL
20	4	PAAP43	POP RIVET, 1/8
21	2	F13262	REINF. PLATE, 5530 DM

CHAMPION HOIST MODEL: 716SFDA

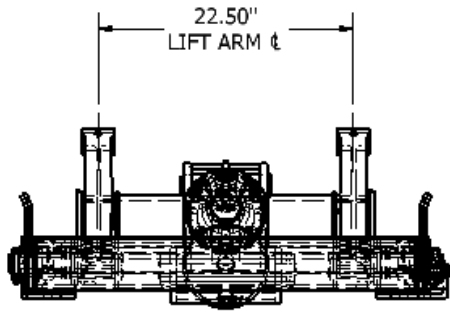

STANDARD SUBFRAME LENGTHS (FT):

10, 11, 12

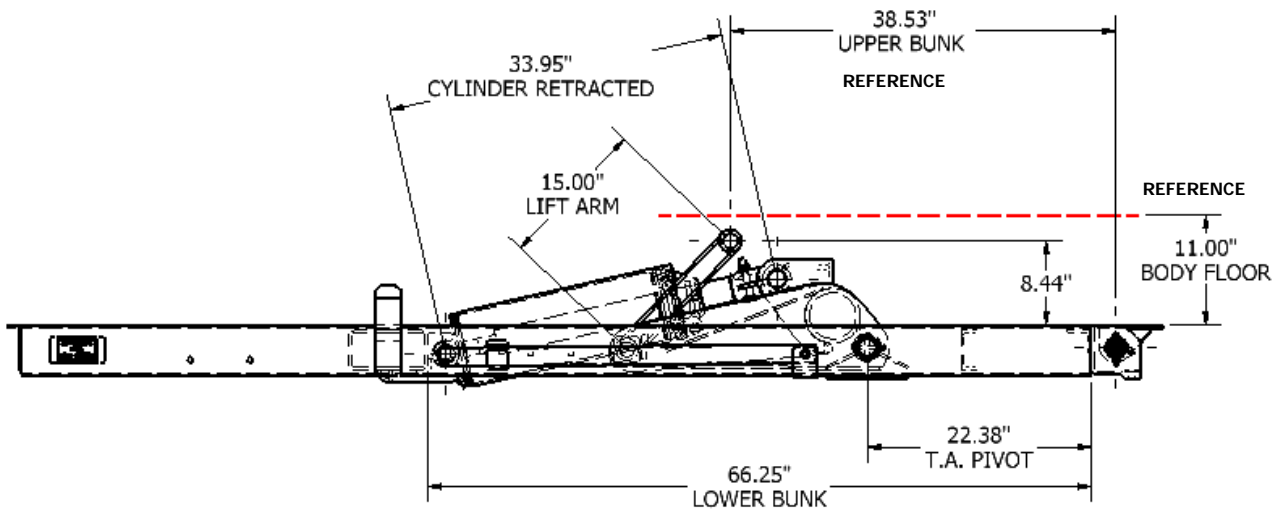

DESIGNED FOR TRUCKS WITH 21,500 TO 25,500 GVW

CHAMPION

Hoist and Equipment

Dunn, North Carolin, U.S.A.

910 - 897 - 4995

Fax 910 - 897 - 6822

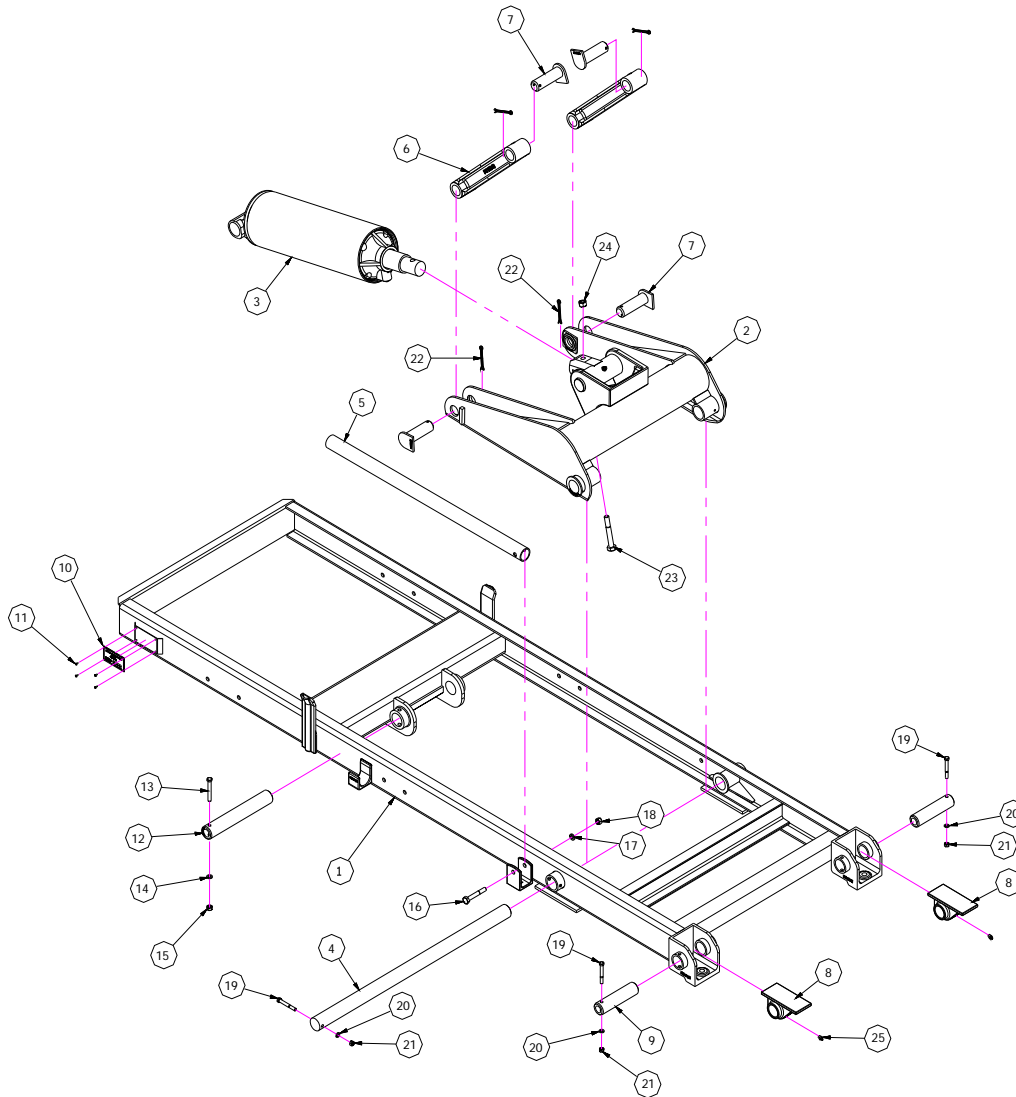

Parts List			
ITEM	QTY	PART NUMBER	DESCRIPTION
1	1	W13435C	WELDMENT SUBFRAME
2	1	W12134C	WELDMENT TORQUE ARM
3	1	716CYLINDER	CYLINDER, UNDERBODY
4	1	SM13018C	SHAFT, TORQUE ARM PIVOT
5	1	SM13033C	STAND, SAFETY
6	2	PC10340C	LIFT ARM, 16"
7	4	PC10345C	PIN, LIFT ARM
8	2	PC10463C	REAR HINGE BLOCK
9	2	PC10525C	PIN, REAR HINGE
10	1	P10100C	SERIAL PLATE
11	4	PAAP43	RIVET
12	1	PC10559C	PIN, CYLINDER
13	1	102-313-A1	HEX BOLT, 7/16-14 UNC X 3
14	1	118-4-A1	LOCK WASHER, 7/16
15	1	116-4-A1	HEX NUT, 7/16-14 UNC
16	1	102-415-A1	HEX BOLT, 1/2-13 UNC X 3 1/2 GR8
17	1	118-5-A1	LOCK WASHER, 1/2
18	1	116-5-A1	HEX NUT, 1/2-13 UNC
19	3	102-213-A1	HEX BOLT, 3/8-16 UNC X 3
20	3	118-3-A1	LOCK WASHER, 3/8
21	3	116-3-A1	HEX NUT, 3/8-16 UNC
22	4	125-260	COTTER PIN, 1/4 X 3
23	1	102-617-L	HEX BOLT, 5/8-11 UNC X 4, GR 9
24	1	143-7	LOCK NUT, 5/8
25	9	PT7608	GREASE FITTING

CHAMPION
Hoist and Equipment

716SFDA 10ft.

CHAMPION HOIST MODEL: U740, U750

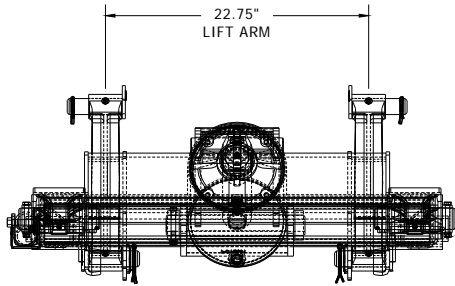

STANDARD SUBFRAME LENGTHS (FT):

10, 11

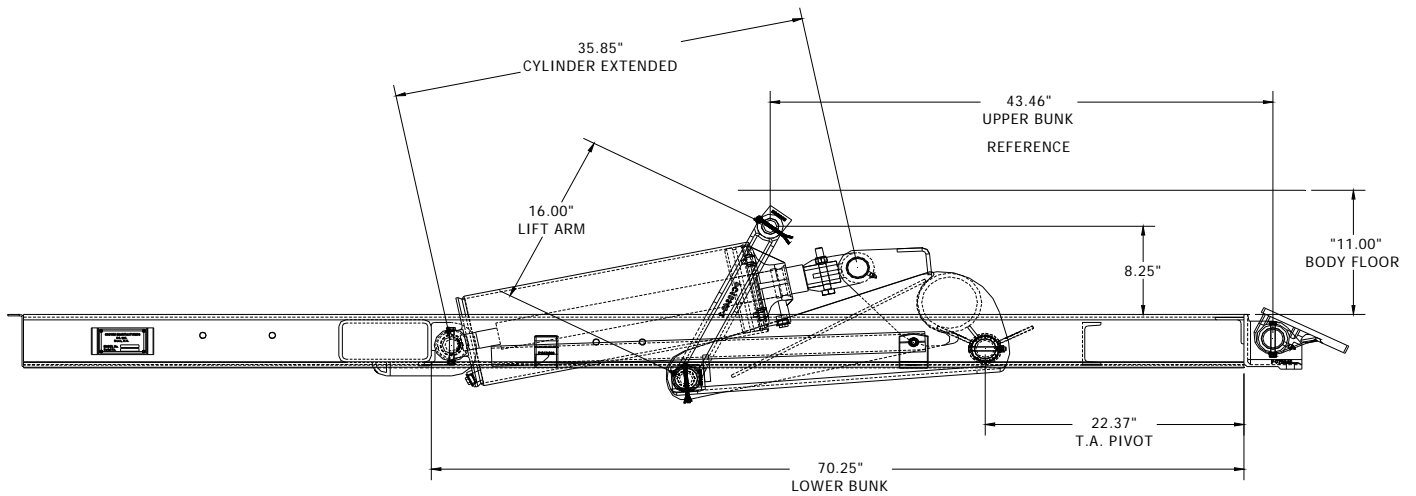

DESIGNED FOR TRUCKS WITH 21,500 TO 25,500 GVW

CHAMPION

Hoist and Equipment

Dunn, North Carolin, U.S.A.

910 - 897 - 4995

Fax 910 - 897 - 6822

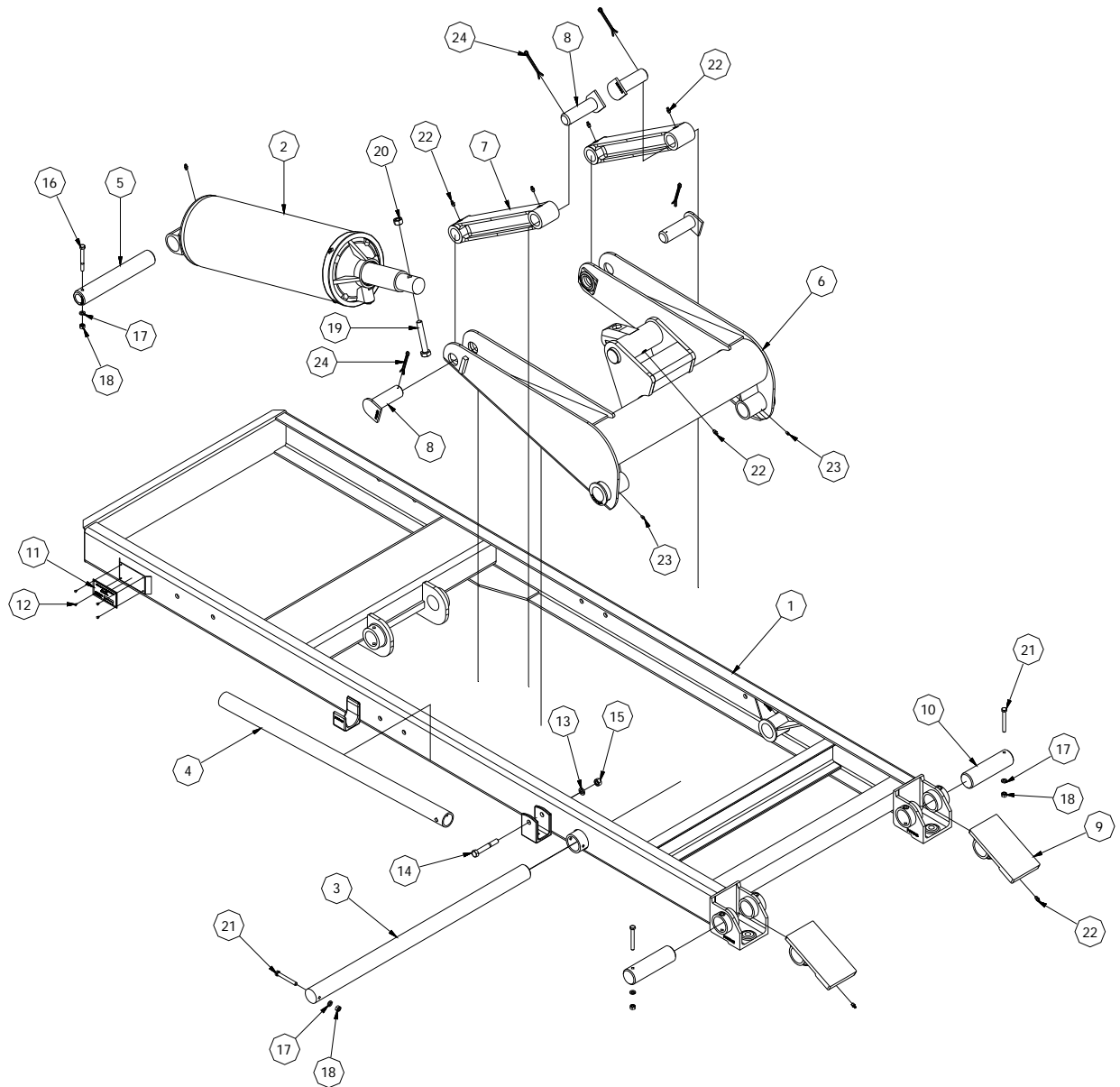

PARTS LIST

ITEM	QTY	PART NUMBER	DESCRIPTION
1	1	W13414	SUBFRAME WELDMENT, 10'- (MTA) U740-750-850-860 (10FT)
2	1	CYLINDER	U740/750 USE 720CYLINDER, U850/860 USE 820CYLINDER
3	1	SM13018	TORQUE ARM PIVOT PIN - 718/816
4	1	SM13033	STAND, SAFETY - 716/816
5	1	PC10559	816/820 LOWER CYLINDER PIN
6	1	W12380	GALION 820 TORQUE ARM WELDMENT
7	2	PC10340-16	LIFT ARM, 16" TORQUE ARM CASTING
8	4	PC10345	PIN, LIFT ARM - TORQUE ARM TAILGATE OFFSET HARDWARE CASTING
9	2	PC70042	REAR HINGE FLIPPER, Ø2" WIDE FLANGE
10	2	PC70041	REAR HINGE SHAFT, SOLID, 2"
11	1	P10100	PLATE, SERIAL
12	4	PAAP43	RIVET, 1/8" CHERRY POP
13	1	118-5-A1	Lock Washer, 1/2
14	1	102-415-A1	Hex Bolt, 1/2-13 UNC x 3 1/2 GRD8
15	1	116-5-A1	Hex Nut, 1/2
16	1	102-214	Hex Bolt, 3/8 UNC x 3 1/4
17	4	118-3-A1	Lock Washer, 3/8
18	4	116-3-A1	Hex Nut, 3/8 UNC
19	1	102-617-A1	HEX BOLT, 5/8 X 4, GR 8
20	1	143-7	NUT, LOCK, 5/8 UNC
21	3	102-213-A1	HEX BOLT, 3/8" x 3"
22	8	P800	3/8" GREASE FITTING, PIPE THREAD
23	2	PT7608	Grease Fitting
24	4	125-260	COTTER PIN, 1/4 X 3

ASSEMBLY, 10 FT, U740/750

CHAMPION HOIST MODEL: U850D—U860D

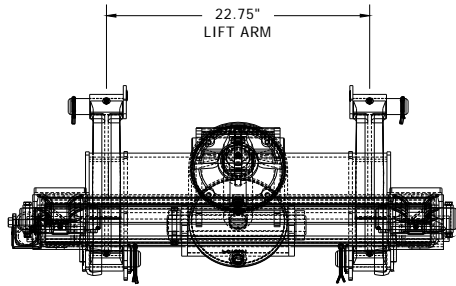

STANDARD SUBFRAME LENGTHS
(FT):

10, 11

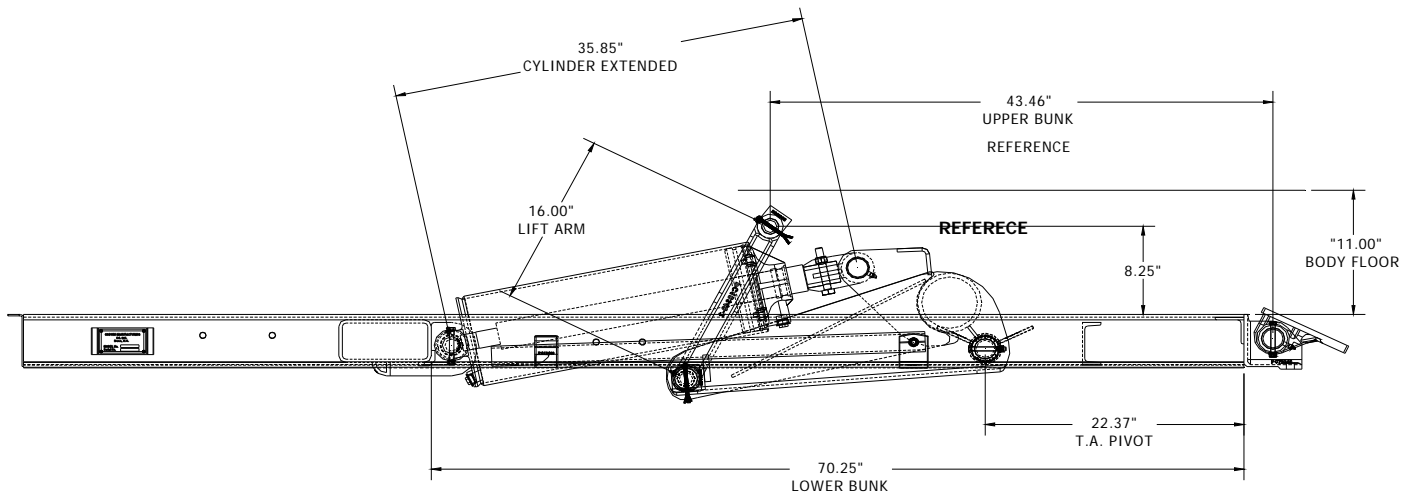

DESIGNED FOR TRUCKS WITH 24,000 TO 38,000 GVW

CHAMPION

Hoist and Equipment

Dunn, North Carolin, U.S.A.

910 - 897 - 4995

Fax 910 - 897 - 6822

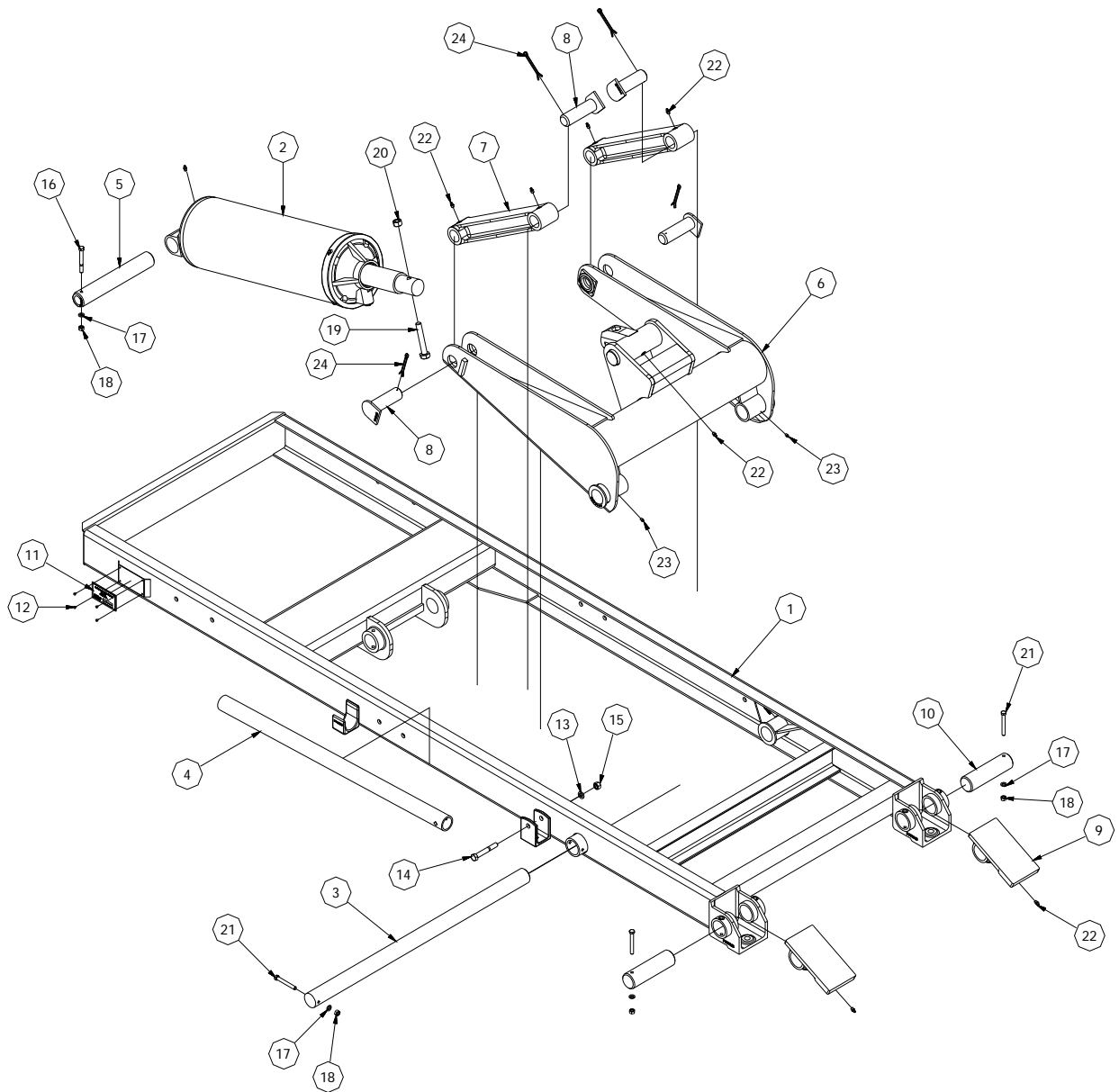

PARTS LIST

ITEM	QTY	PART NUMBER	DESCRIPTION
1	1	W13414	SUBFRAME WELDMENT, 10'- (MTA) U740-750-850-860 (10FT)
2	1	CYLINDER	U740/750 USE 720CYLINDER, U850/860 USE 820CYLINDER
3	1	SM13018	TORQUE ARM PIVOT PIN - 718/816
4	1	SM13033	STAND, SAFETY - 716/816
5	1	PC10559	816/820 LOWER CYLINDER PIN
6	1	W12380	GALION 820 TORQUE ARM WELDMENT
7	2	PC10340-16	LIFT ARM, 16" TORQUE ARM CASTING
8	4	PC10345	PIN, LIFT ARM - TORQUE ARM TAILGATE OFFSET HARDWARE CASTING
9	2	PC70042	REAR HINGE FLIPPER, Ø2" WIDE FLANGE
10	2	PC70041	REAR HINGE SHAFT, SOLID, 2"
11	1	P10100	PLATE, SERIAL
12	4	PAAP43	RIVET, 1/8" CHERRY POP
13	1	118-5-A1	Lock Washer, 1/2
14	1	102-415-A1	Hex Bolt, 1/2-13 UNC x 3 1/2 GRD8
15	1	116-5-A1	Hex Nut, 1/2
16	1	102-214	Hex Bolt, 3/8 UNC x 3 1/4
17	4	118-3-A1	Lock Washer, 3/8
18	4	116-3-A1	Hex Nut, 3/8 UNC
19	1	102-617-L	HEX BOLT, 5/8-11 UNC X 4, GR 9
20	1	143-7	NUT, LOCK, 5/8 UNC
21	3	102-213-A1	HEX BOLT, 3/8" x 3"
22	8	P800	3/8" GREASE FITTING, PIPE THREAD
23	2	PT7608	Grease Fitting
24	4	125-260	COTTER PIN, 1/4 X 3

ASSEMBLY, 10 FT, U850/860

CHAMPION HOIST MODEL: 826SFDAP, 8826SFDAP , 7726SFDA

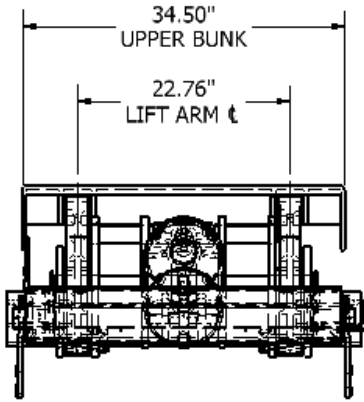

** 826SFDA SHOWN

STANDARD SUBFRAME LENGTHS (FT):

826— 10, 11, 12

7726— 10, 11, 12

8826— 10, 11, 12, 13, 14

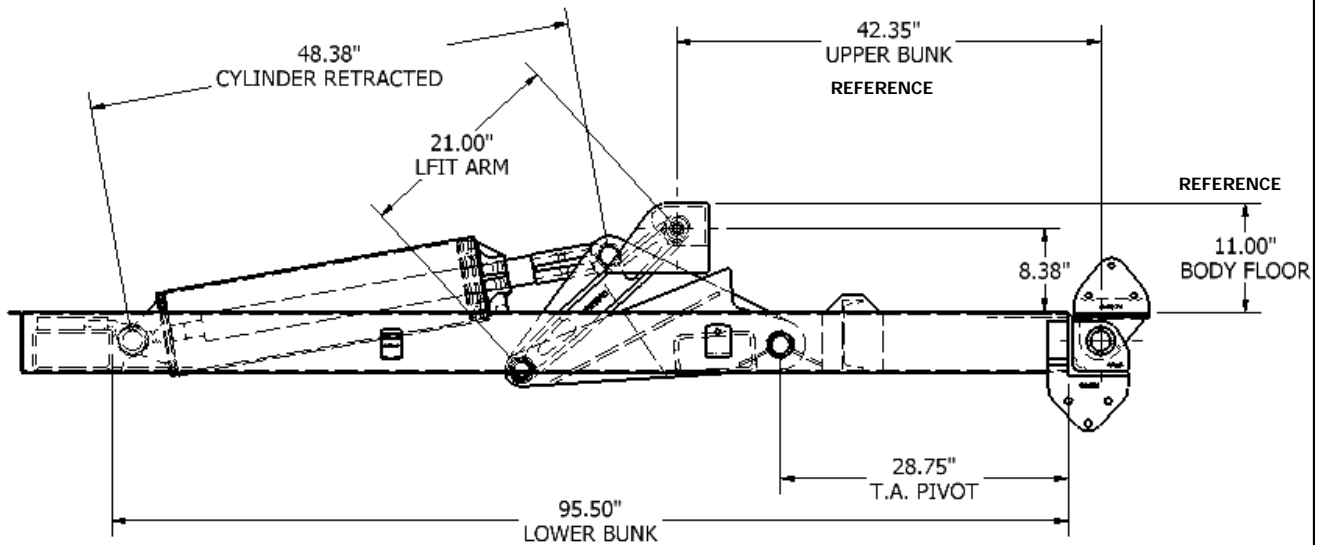

** SAME AS 826SFDA WITH EXCEPTION OF TWO CYLINDERS

DESIGNED FOR TRUCKS WITH 28,000 TO 35,000 GVW

CHAMPION

Hoist and Equipment

Dunn, North Carolin, U.S.A.

910 - 897 - 4995

Fax 910 - 897 - 6822

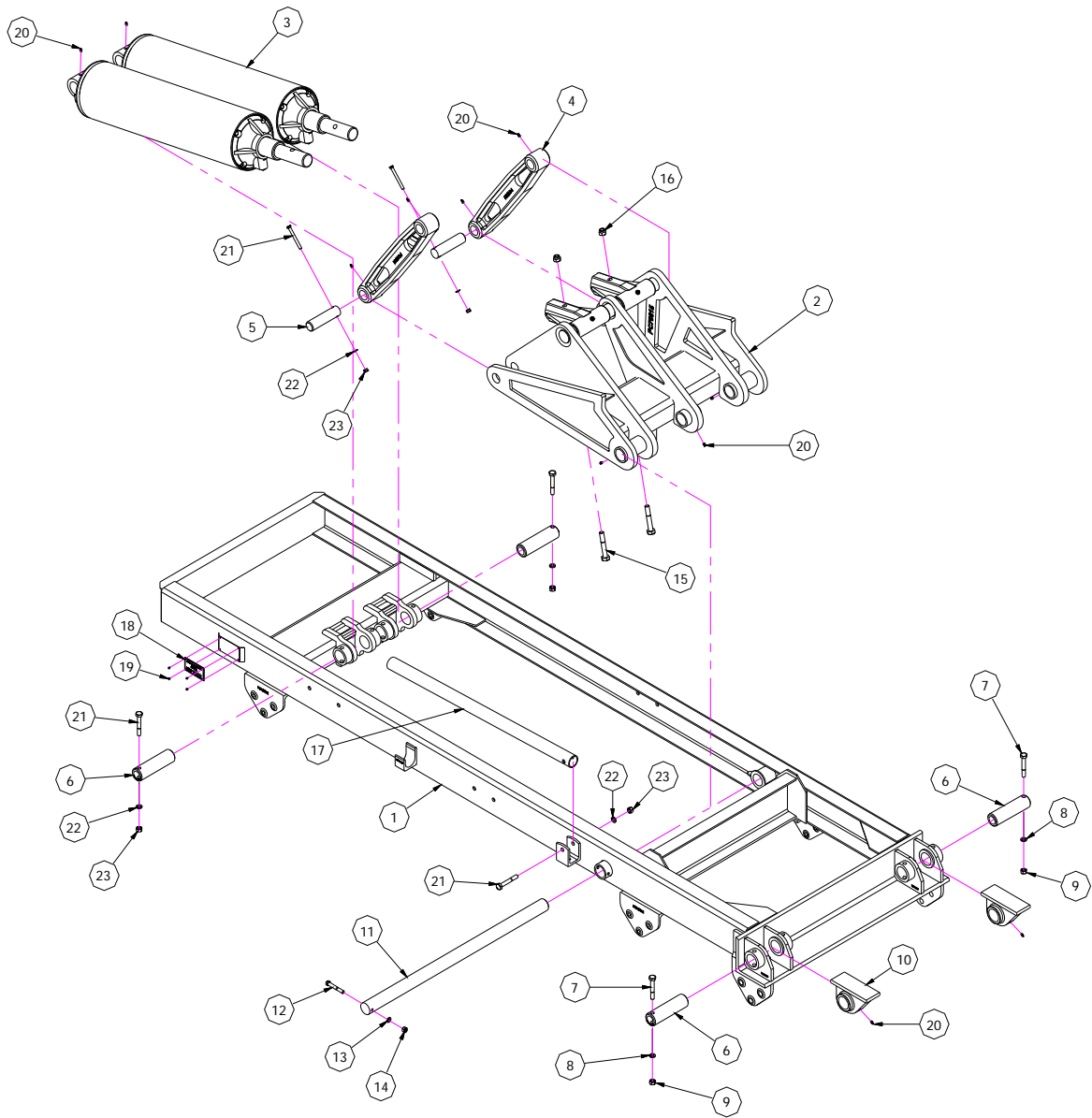

Parts List			
ITEM	QTY	PART NUMBER	DESCRIPTION
1	1	W13438	WELDMENT SUBFRAME 8826-14
2	1	W13407	WELDMENT TORQUE ARM 8826
3	2	726-DA	CYLINDER, UNDERBODY
4	2	PC10701	LIFT ARM, 826
5	2	SM13104	PIN, LIFT ARM 7734/8834
6	4	PC10523	PIN 2"
7	5	102-415-A1	HEX BOLT, 1/2 -13 UNC X 3 1/2, GR 8
8	5	118-5-A1	LOCK WASHER, 1/2
9	5	116-5-A1	HEX NUT, 1/2
10	2	PC10335	2" REAR HINGE
11	1	SM13018	SHAFT, TORQUE ARM PIVOT
12	1	102-313-A1	HEX BOLT, 7/16-14 UNC X 3
13	1	118-4-A1	LOCK WASHER, 7/16
14	1	116-4-A1	HEX NUT, 7/16-14 UNC
15	2	102-617-L	HEX BOLT, 5/8-11 UNC X 4, GR 9
16	2	143-7	LOCK NUT, 5/8
17	1	SM13033	STAND, SAFETY
18	1	P10200	SERIAL PLATE
19	4	PAAP43	POP RIVET, 1/8
20	13	PT7608	GREASE FITTING
21	5	102-215-A1	HEX BOLT, 3/8-16 UNC X 3 1/2
22	5	118-3-A1	LOCK WASHER, 3/8
23	5	116-3-A1	HEX NUT, 3/8-16 UNC



7726SFDA 14ft.

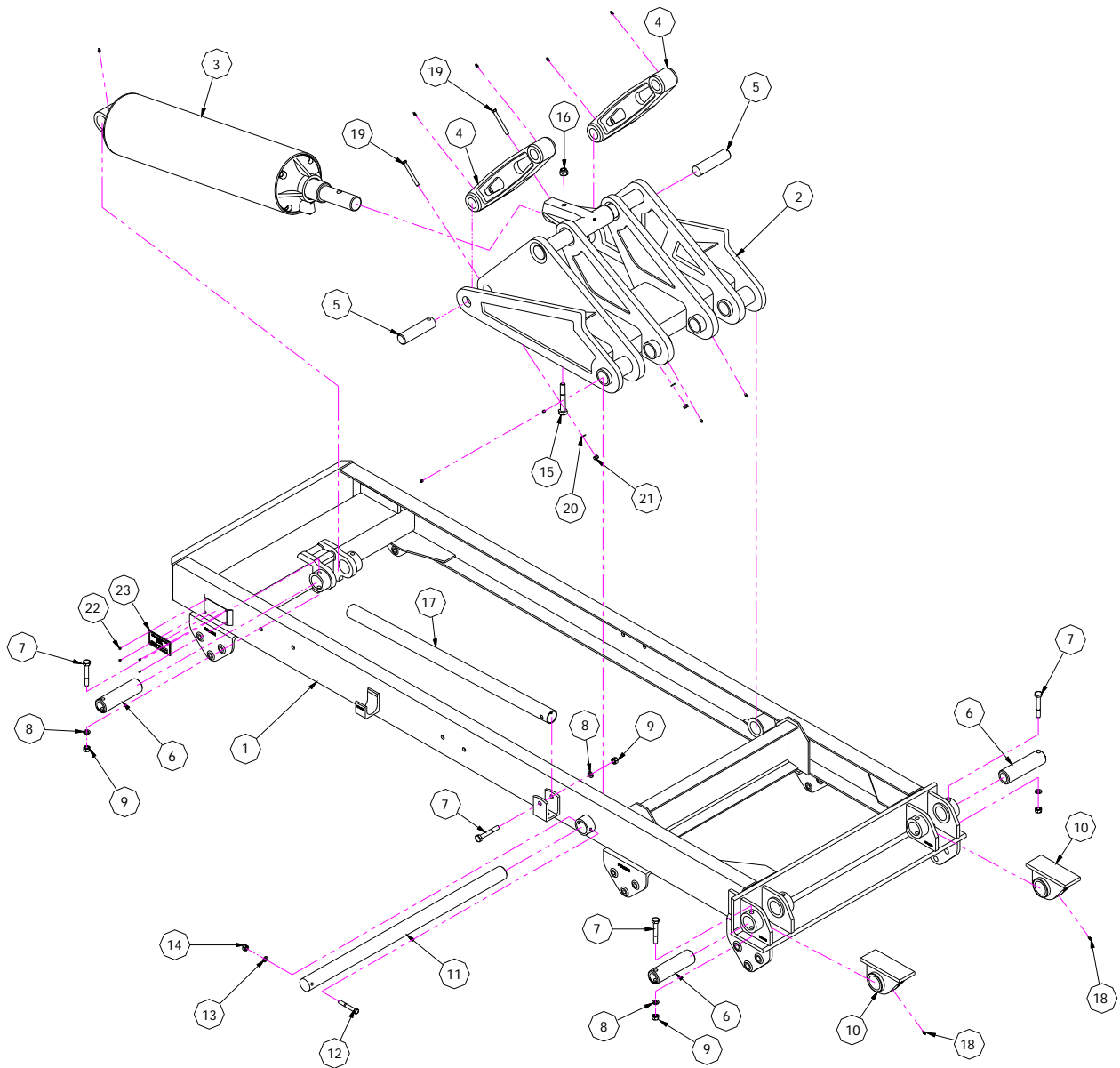

Parts List

ITEM	QTY	PART NUMBER	DESCRIPTION
1	1	W13334	SUBFRAME WELDMENT 826-10
2	1	W13338	TORQUE ARM WELDMENT 826
3	1	826 DA	CYLINDER, UNDERBODY
4	2	PC10701	LIFT ARM, 826
5	2	SM13104	PIN, LIFT ARM 826/7734/8834
6	3	PC10523	PIN 2"
7	4	102-415-A1	HEX BOLT, 1/2-13 UNC X 3 1/2, GR8
8	4	118-5-A1	LOCK WASHER, 1/2
9	4	116-5-A1	HEX NUT, 1/2
10	2	PC10335	REAR HINGE, 2"
11	1	SM13018	SHAFT, TORQUE ARM PIVOT
12	1	102-313-A1	HEX BOLT, 7/16-14 UNC X3
13	1	118-4-A1	LOCK WASHER, 7/16
14	1	116-4-A1	HEX NUT, 7/16-14 UNC
15	1	102-617-L	HEX BOLT, 5/8-11 UNC X 4, GR9
16	1	143-7	LOCK NUT, 5/8
17	1	SM13033	STAND, SAFETY
18	12	PT7608	GREASE FITTING
19	2	102-215-A1	HEX BOLT, 3/8-16 UNC X 3 1/2
20	2	118-3-A1	LOCK WASHER, 3/8
21	2	116-3-A1	HEX NUT, 3/8-16 UNC
22	4	PAAP43	PDP RIVET, 1/8
23	1	PI0200	SERIAL PLATE



826SFDAP 10ft.

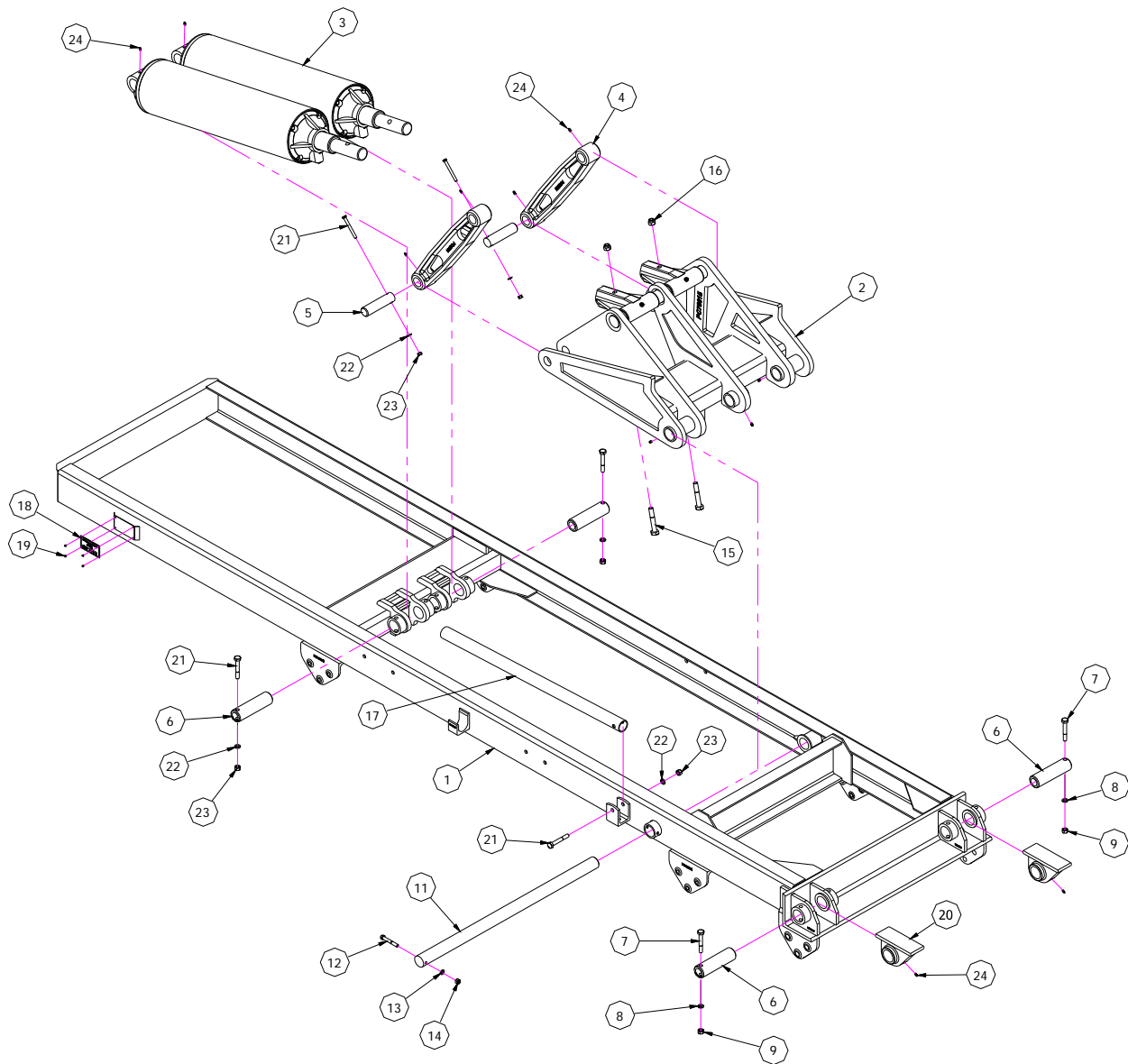

Parts List

ITEM	QTY	PART NUMBER	DESCRIPTION
1	1	W13438	WELDMENT SUBFRAME 8826-14
2	1	W13407	WELDMENT TORQUE ARM 8826
3	2	826-DA	CYLINDER, UNDERBODY
4	2	PC10701	LIFT ARM, 826
5	2	SM13104	PIN, LIFT ARM 7734/8834
6	4	PC10523	PIN 2"
7	5	102-415-A1	HEX BOLT, 1/2 -13 UNC X 3 1/2, GR 8
8	5	118-5-A1	LOCK WASHER, 1/2
9	5	116-5-A1	HEX NUT, 1/2
10	2	PC10335	2" REAR HINGE
11	1	SM13018	SHAFT, TORQUE ARM PIVOT
12	1	102-313-A1	HEX BOLT, 7/16-14 UNC X 3
13	1	118-4-A1	LOCK WASHER, 7/16
14	1	116-4-A1	HEX NUT, 7/16-14 UNC
15	2	102-617-L	HEX BOLT, 5/8-11 UNC X 4, GR 9
16	2	143-7	LOCK NUT, 5/8
17	1	SM13033	STAND, SAFETY
18	1	P10200	SERIAL PLATE
19	4	PAAP43	POP RIVET, 1/8
20	13	PT7608	GREASE FITTING
21	5	102-215-A1	HEX BOLT, 3/8-16 UNC X 3 1/2
22	5	118-3-A1	LOCK WASHER, 3/8
23	5	116-3-A1	HEX NUT, 3/8-16 UNC
24	5	PT7608	GREASE FITTING

CHAMPION
Hoist and Equipment

8826SFDAP 14ft.

CHAMPION HOIST MODEL: 734SFDAP, 834SFDAP, 7734SFDA, 8834SFDAP

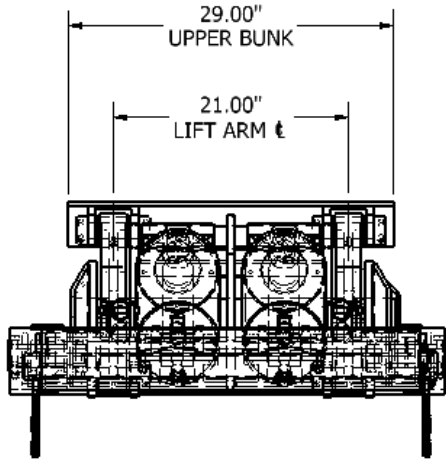

STANDARD SUBFRAME LENGTHS (FT):
14, 15, 16

8834SFDA SHOWN

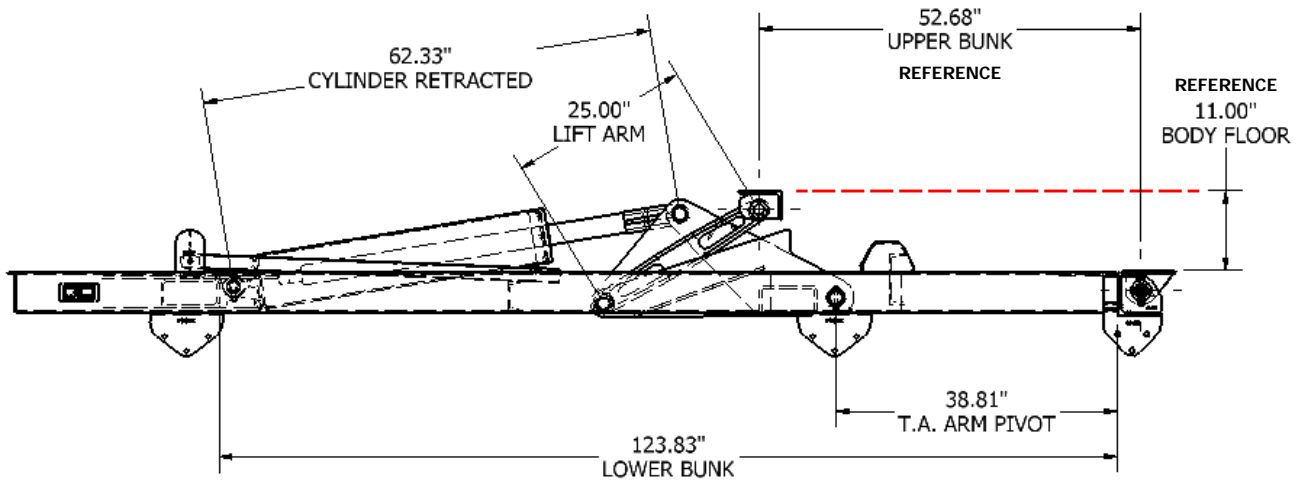

DESIGNED FOR TRUCKS WITH 50,000 GVW

REAR HINGE INSTALLATION

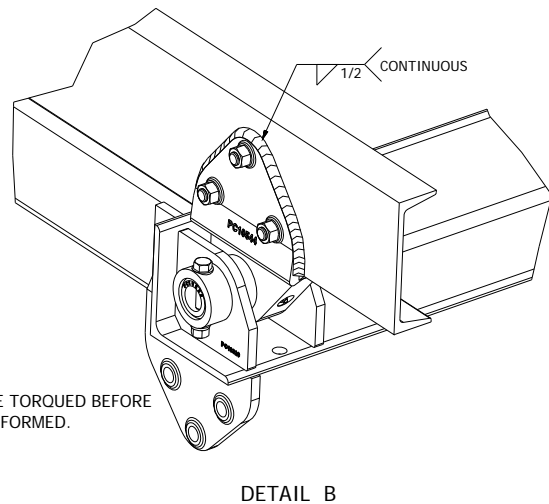
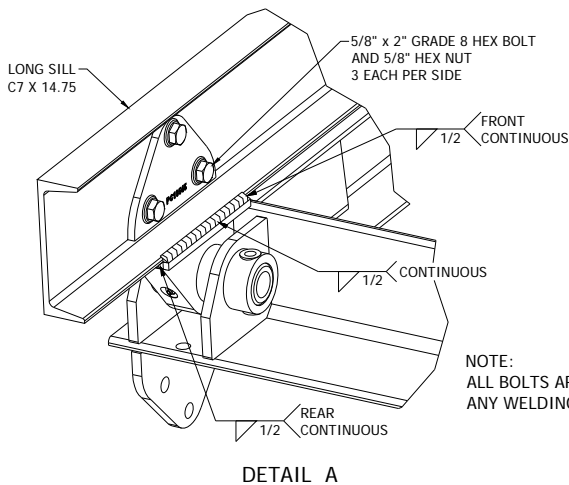

NOTE:
ALL BOLTS ARE TO BE TORQUED BEFORE
ANY WELDING IS PERFORMED.

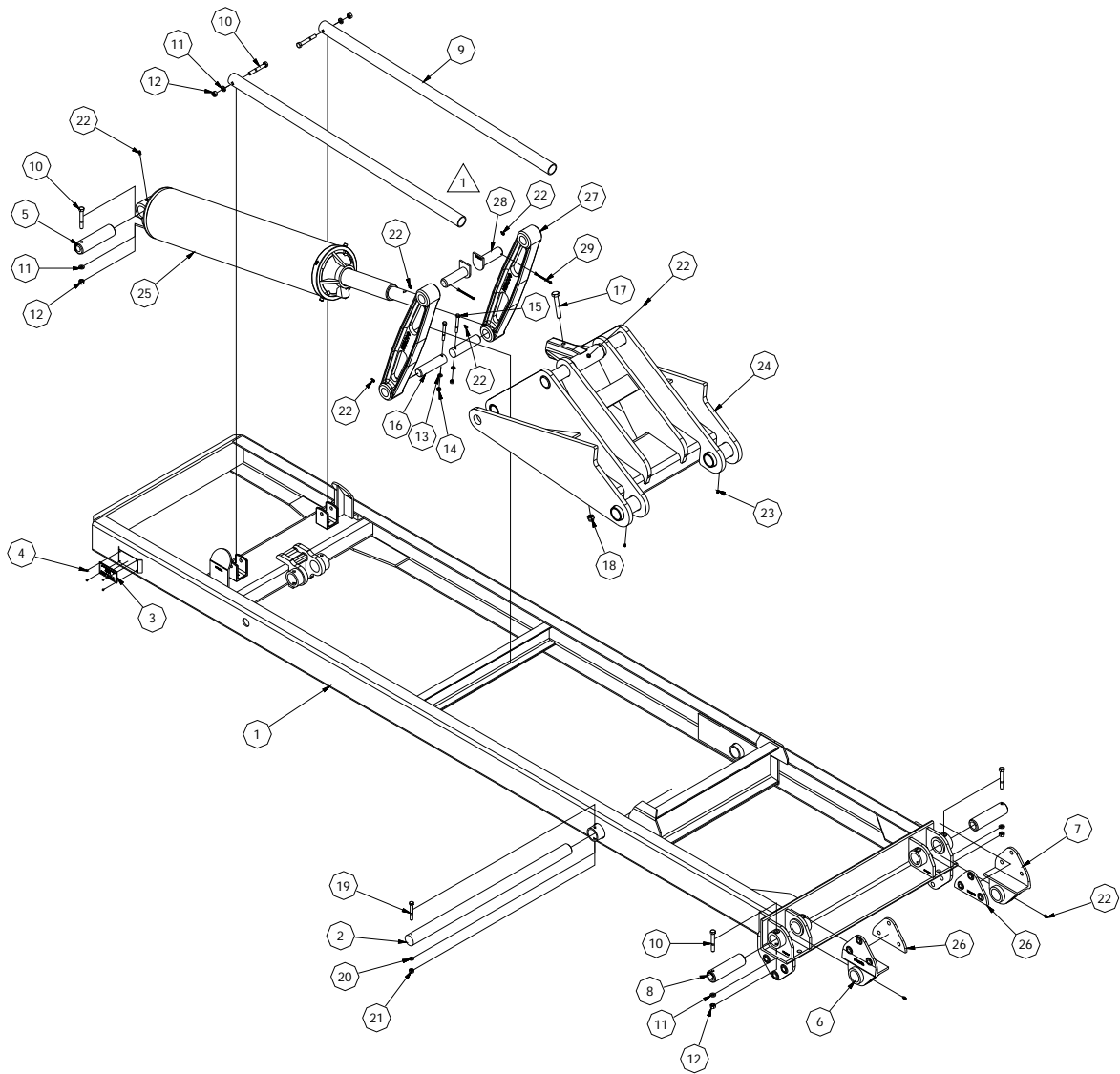

PARTS LIST			
ITEM	QTY	PART NUMBER	DESCRIPTION
1	1	W13705	WELDMENT - SUBFRAME 734/834 - 14'
2	1	SM13018	TORQUE ARM PIVOT PIN - 718/816
3	1	P10100	PLATE, SERIAL
4	4	PAAP43	RIVET, 1/8" CHERRY POP
5	1	PC10564	7-1/2" PIN LOWER CYLINDER PIN FOR 7734/8834 - 834
6	1	PC10544	2" BOLT ON REAR HINGE (L)
7	1	PC10543	2" BOLT ON REAR HINGE (R)
8	2	PC10523	REAR HINGE PIN 2"
9	2	SM13208	STAND, SAFETY 52" LG.
10	5	102-415-A1	Hex Bolt, 1/2-13 UNC x 3 1/2 GRD8
11	5	118-5-A1	LOCK WASHER, 1/2
12	5	116-5-A1	HEX NUT, 1/2 -13 UNC
13	2	118-3-A1	Lock Washer, 3/8
14	2	116-3-A1	Hex Nut, 3/8 UNC
15	2	102-214	Hex Bolt, 3/8 UNC x 3 1/4
16	2	SM13104	PIN, LIFT ARM - 7734/8834
17	1	102-617-A1	HEX BOLT, 5/8 X 4, GR 8
18	1	162-12-S	LOCK NUT, 5/8
19	1	102-313-A1	Hex Bolt, 7/16-14 UNC x 3
20	1	118-4-A1	Lock Washer, 7/16
21	1	116-4-A1	Hex Nuts, 7/16-14 UNC
22	8	P800	1/8" GREASE FITTING, PIPE THREAD
23	2	PT7608	Grease Fitting
24	1	W13409	734/834 TORQUE ARM
25	1	734/834 Cylinder with 2.75 Shaft	734/834 Cylinder with 2.75 Shaft
26	2	PC10545	BACKING PLATE FOR BOLT-ON REAR HINGE
27	2	PC10365	LIFT ARM, 20" TORQUE ARM CASTING
28	2	PC10345	PIN, LIFT ARM - TORQUE ARM TAILGATE OFFSET HARDWARE CASTING
29	2	125-257	PIN, COTTER 2"

REVISION HISTORY			
ZONE	REV	DESCRIPTION	DATE APPROVED
	1	REPLACED PIN PC13299 WITH PC10345	9/7/2011 Chip Loworn

734/834 SFDAP ASSEMBLY



A13749

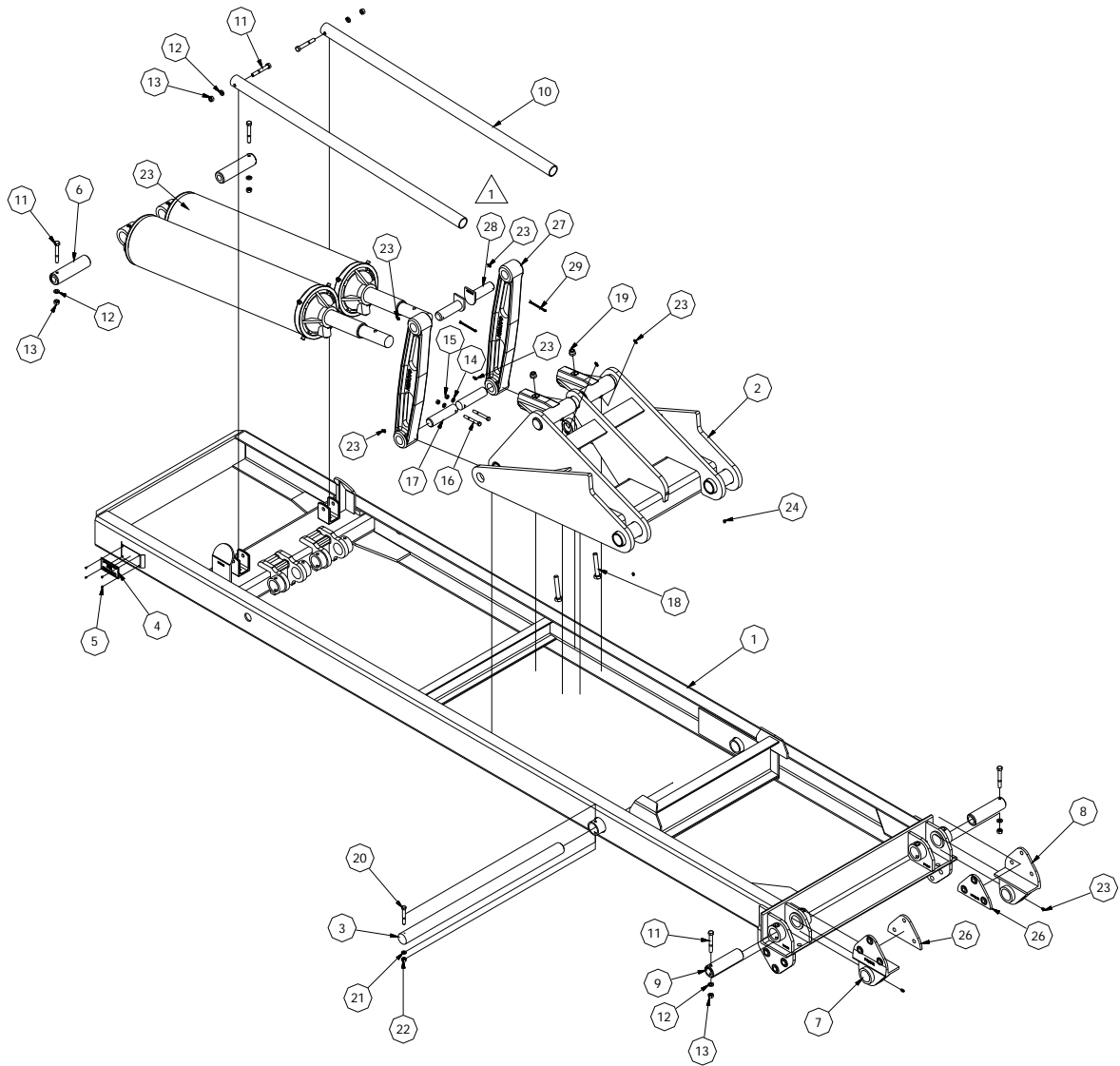

PARTS LIST			
ITEM	QTY	PART NUMBER	DESCRIPTION
1	1	W13437	WELDMENT - SUBFRAME 734/834 - 14'
2	1	W13192	WELDMENT, 7734/8834 TORQUE ARM
3	1	SM13018	TORQUE ARM PIVOT PIN - 718/816
4	1	P10100	PLATE, SERIAL
5	4	PAAP43	RIVET, 1/8" CHERRY POP
6	2	PC10564	7-1/2" PIN LOWER CYLINDER PIN FOR 8834 - 7734 & 834
7	1	PC10544	2" BOLT ON REAR HINGE (L)
8	1	PC10543	2" BOLT ON REAR HINGE (R)
9	2	PC10523	REAR HINGE PIN 2"
10	2	SM13208	STAND, SAFETY 52" LG.
11	6	102-415-A1	Hex Bolt, 1/2-13 UNC x 3 1/2 GRD8
12	6	118-5-A1	LOCK WASHER, 1/2
13	6	116-5-A1	HEX NUT, 1/2 -13 UNC
14	2	118-3-A1	Lock Washer, 3/8
15	2	116-3-A1	Hex Nut, 3/8 UNC
16	2	102-214	Hex Bolt, 3/8 UNC x 3 1/4
17	2	SM13104	PIN, LIFT ARM - 7734/8834
18	2	102-617-A1	HEX BOLT, 5/8 X 4, GR 8
19	2	162-12-S	LOCK NUT, 5/8
20	1	102-313-A1	Hex Bolt, 7/16-14 UNC x 3
21	1	118-4-A1	Lock Washer, 7/16
22	1	116-4-A1	Hex Nuts, 7/16-14 UNC
23	10	P800	1/8" GREASE FITTING, PIPE THREAD
24	2	PT7608	Grease Fitting
25	2	834cylinder with 2.75 shaft	834 Cylinder with 2.5 shaft
26	2	PC10545	BACKING PLATE FOR BOLT-ON REAR HINGE
27	2	PC10365	LIFT ARM, 20" TORQUE ARM CASTING
28	2	PC10345	PIN, LIFT ARM - TORQUE ARM TAILGATE OFFSET HARDWARE CASTING
29	2	125-257	PIN, COTTER 2"

REVISION HISTORY				
ZONE	REV	DESCRIPTION	DATE	APPROVED
	1	REPLACED PIN PC13299 WITH PC10345	9/7/2011	Chip Iovorn

7734/8834 SFDAP ASSEMBLY

GODWIN MFG. CO., INC.
DUNN, NORTH CAROLINA

A13435

CHAMPION HOIST MODEL: 816SFDAP

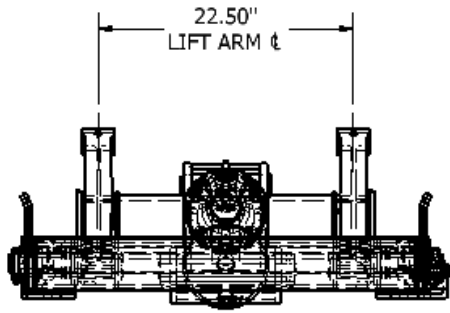

STANDARD SUBFRAME LENGTHS (FT):
10, 11, 12

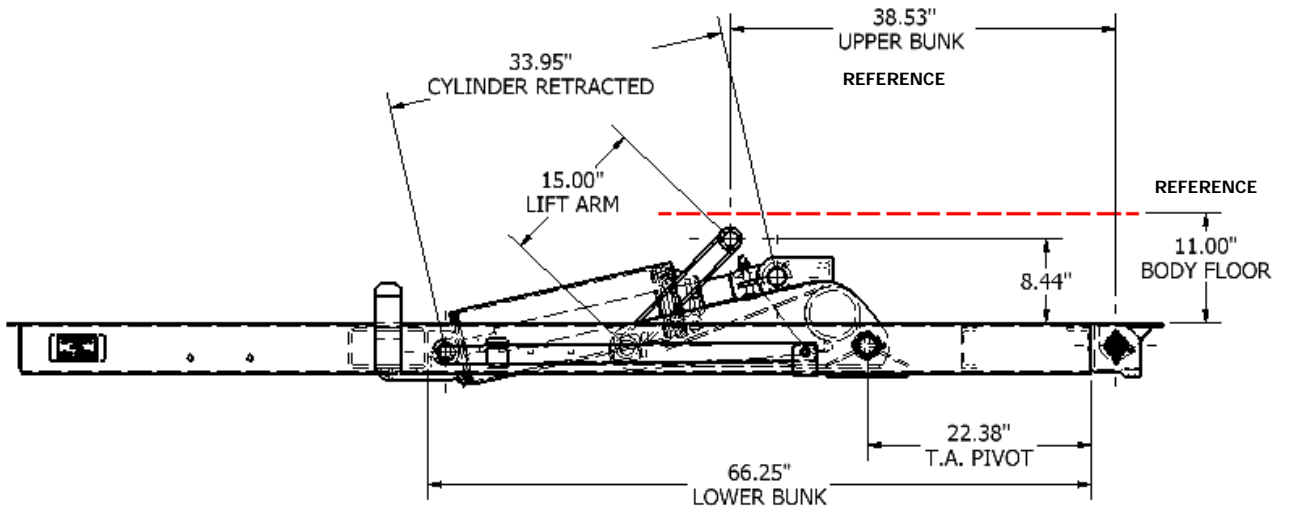

DESIGNED FOR TRUCKS WITH 24,000 TO 35,000 GVW

CHAMPION

Hoist and Equipment
Dunn, North Carolina, U.S.A.

910 - 897 - 4995

Fax 910 - 897 - 6822

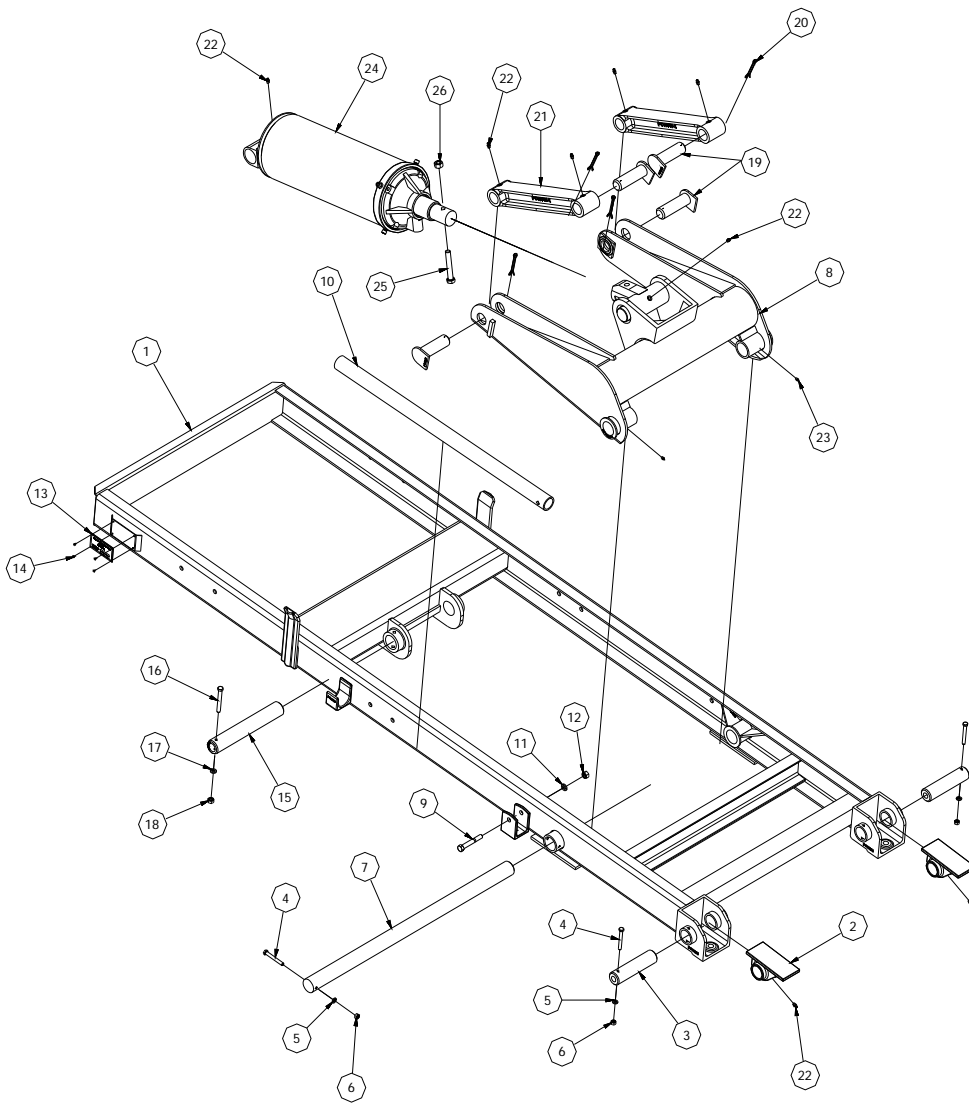

PARTS LIST				
ITEM	QTY	PART NUMBER	DESCRIPTION	
1	1	W13429	WELDMENT - SUBFRAME 716/816 -10'	
2	2	PC10463	HINGE - 1-3/4" FLIPPER	
3	2	PC10525	REAR HINGE PIN 816-820 SF	
4	3	102-213-A1	HEX BOLT, 3/8" x 3"	
5	3	118-3-A1	Lock Washer, 3/8	
6	3	116-3-A1	Hex Nut, 3/8 UNC	
7	1	SM13018	TORQUE ARM PIVOT PIN - 718/816	
8	1	W12134	TORQUE ARM WELDMENT	
9	1	102-415-A1	Hex Bolt, 1/2-13 UNC x 3 1/2 GRD8	
10	1	SM13033	STAND, SAFETY - 716/816	
11	1	118-5-A1	Lock Washer, 1/2	
12	1	116-5-A1	Hex Nut, 1/2	
13	1	P10100	PLATE, SERIAL	
14	4	PAAP43	RIVET, 1/8" CHERRY POP	
15	1	PC10559	816/820 LOWER CYLINDER PIN	
16	1	102-315-A1	Hex Cap Screw, 7/16-14 UNC X 3 1/2	
17	1	118-4-A1	Lock Washer, 7/16	
18	1	116-4-A1	Hex Nuts, 7/16-14 UNC	
19	4	PC10345	PIN, LIFT ARM - TORQUE ARM TAILGATE OFFSET HARDWARE CASTING	
20	4	125-260	COTTER PIN, 1/4 X 3	
21	2	PC10340-16	LIFT ARM, 16" TORQUE ARM CASTING	
22	8	P800	1/8" GREASE FITTING, PIPE THREAD	
23	2	PT7608	Grease Fitting	
24	1	A21138	CYLINDER ASSEMBLY, 816 DA	
25	1	102-617-L	Hex Cap Screw, 5/8 x 4, GR 9	
26	1	143-7	NUT, LOCK, 5/8 UNC	

816 SUBFRAME ASSEMBLY

CHAMPION
Roll and Equipment
Dunn, North Carolina, U.S.A.

A13820

CHAMPION HOIST MODEL: 820SFDAP

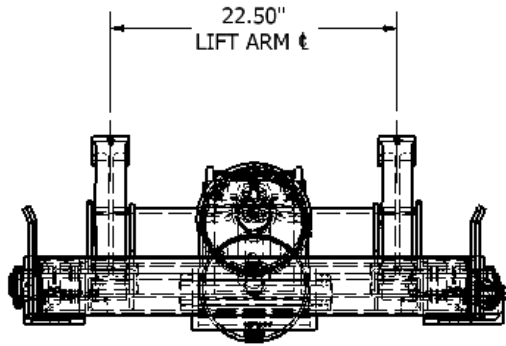

STANDARD SUBFRAME LENGTHS (FT):

10, 11, 12

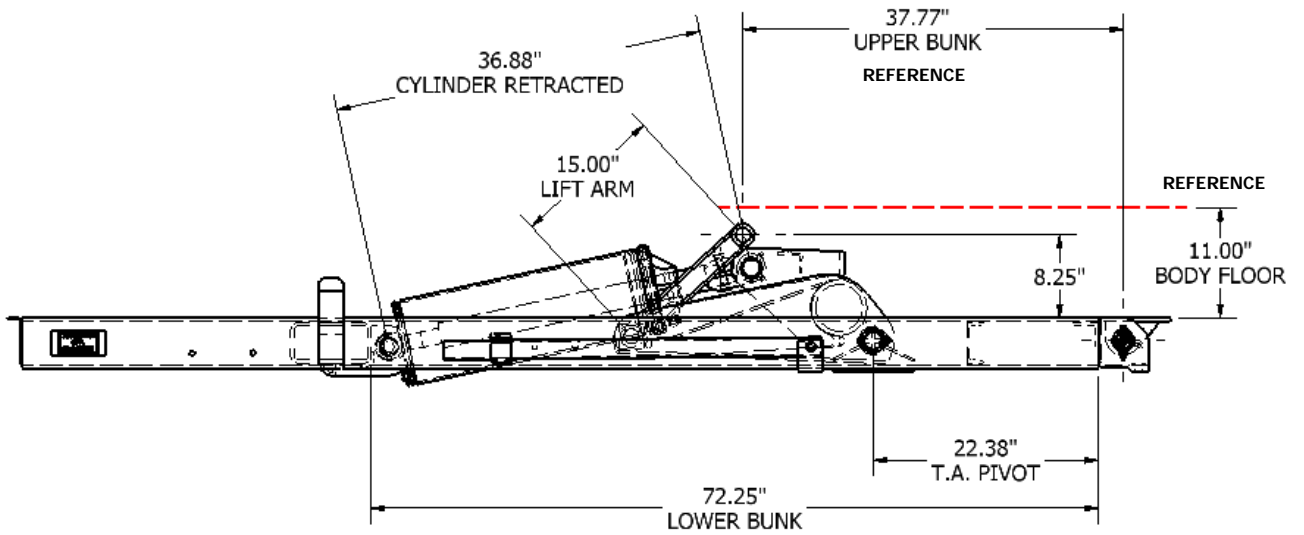

DESIGNED FOR TRUCKS WITH 24,000 TO 35,000 GVW

CHAMPION

Hoist and Equipment

Dunn, North Carolina, U.S.A.

910 - 897 - 4995

Fax 910 - 897 - 6822

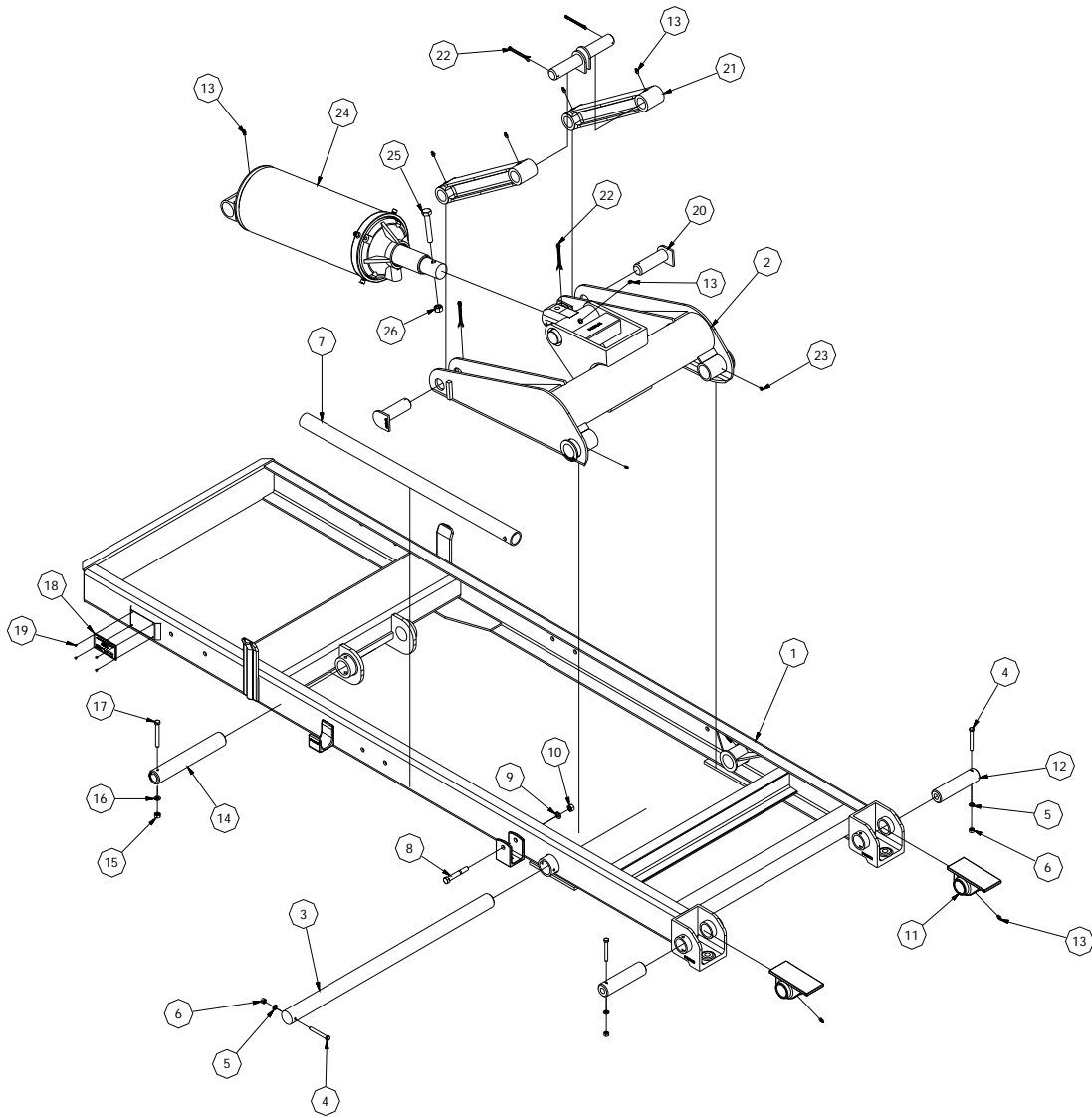

PARTS LIST			
ITEM	QTY	PART NUMBER	DESCRIPTION
1	1	W13326	SUBFRAME WELDMENT - 720/820, 10 FT
2	1	W12135	TORQUE ARM WELDMENT
3	1	SM13018	TORQUE ARM PIVOT PIN - 718/816
4	3	102-213-A1	HEX BOLT, 3/8" x 3"
5	3	118-3-A1	Lock Washer, 3/8
6	3	116-3-A1	Hex Nut, 3/8 UNC
7	1	SM13033	STAND, SAFETY - 716/816
8	1	102-415-A1	Hex Bolt, 1/2-13 UNC x 3 1/2 GRD8
9	1	118-5-A1	Lock Washer, 1/2
10	1	116-5-A1	Hex Nut, 1/2
11	2	PC10463	HINGE - 1-3/4" FLIPPER
12	2	PC10525	REAR HINGE PIN 816-820 SF
13	8	P800	1/8" GREASE FITTING, PIPE THREAD
14	1	PC10559	816/820 LOWER CYLINDER PIN
15	1	116-4-A1	Hex Nuts, 7/16-14 UNC
16	1	118-4-A1	Lock Washer, 7/16
17	1	102-315-A1	Hex Cap Screw, 7/16-14 UNC X 3 1/2
18	1	P10100	PLATE, SERIAL
19	4	PAAP43	RIVET, 1/8" CHERRY POP
20	4	PC10345	PIN, LIFT ARM - TORQUE ARM TAILGATE OFFSET HARDWARE CASTING
21	2	PC10340-16	LIFT ARM, 16" TORQUE ARM CASTING
22	4	125-260	COTTER PIN, 1/4 X 3
23	2	PT7608	Grease Fitting
24	1	A21138	CYLINDER ASSEMBLY, 820 DAP
25	1	102-617-A1	HEX BOLT, 5/8 X 4, GR 8
26	1	143-7	NUT, LOCK, 5/8 UNC

**SUBFRAME ASSEMBLY
820SFDAP 10 FT**