

# CHAMPION

Hoist and Equipment

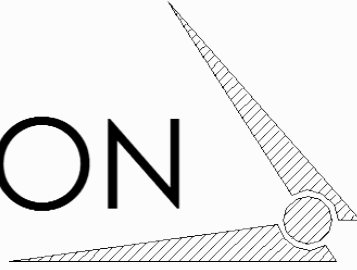

AN AFFILIATE OF



200 CHAMPION DRIVE  
DUNN, NC 28334  
PHONE: (910) 897-4995  
FAX: (910) 897-7306

## Truck Conversion Hoist

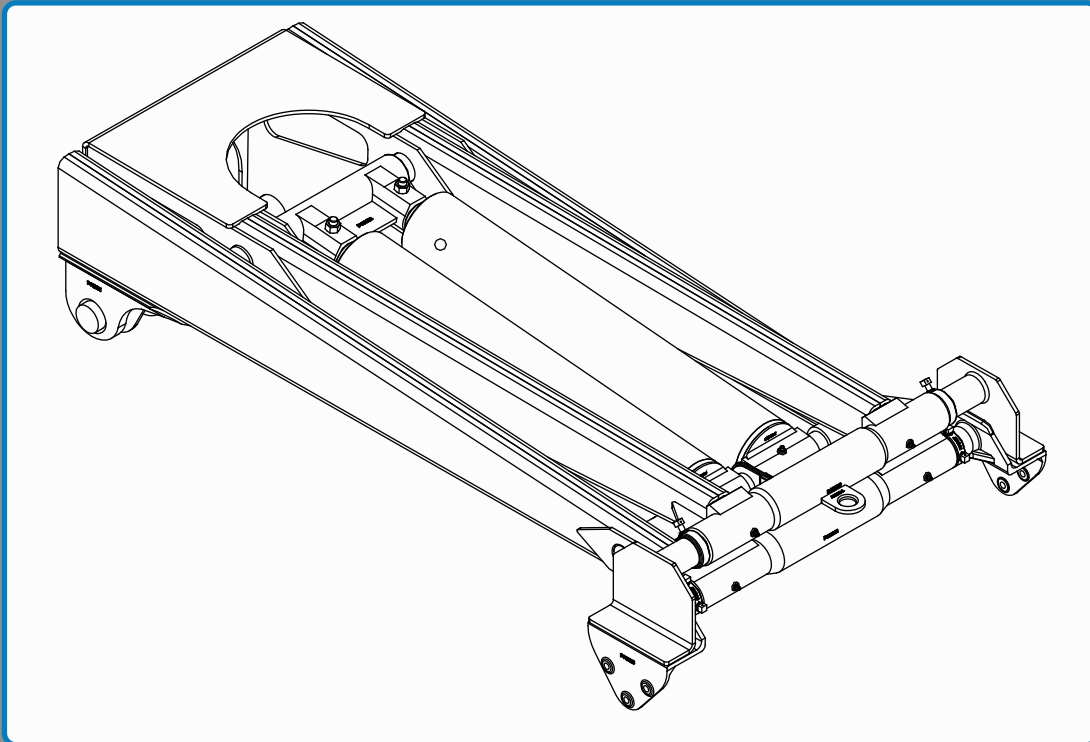

### Service Manual

NOTICE: This manual is to remain with the truck after hoist is installed.

## Notes

It is recommended that the Owner/Operator record the following information immediately after purchasing, so that when calling for Parts or Service, the information will be readily on hand.

### Dump Truck Body

Model Number \_\_\_\_\_

Serial Number \_\_\_\_\_

### Subframe Assembly

Model Number \_\_\_\_\_

Serial Number \_\_\_\_\_

### Hoist Assembly

Model Number \_\_\_\_\_

Serial Number \_\_\_\_\_

### Truck

Year \_\_\_\_\_

Make \_\_\_\_\_

Model \_\_\_\_\_

Truck Number \_\_\_\_\_

September 2021

# Table of Contents

	Page
Safety Alert Symbols	4
Safety Checklist	5
Periodic Inspections	6
Scissor Hoist Pressure Caution	7
Power Take Off (PTO) Pump	8
Pump Rotation and Porting	9
Hydraulic Plumbing Diagram	10
Hydraulic Plumbing Diagram, Single Acting Electric Pump (PD40048)	11
Hydraulic Plumbing Diagram, Double Acting Electric Pump (PD40045)	12
Electric Pump Priming Procedure (MP50398)	13
Electric Pump Troubleshooting Procedure (MP50399)	14
Champion 8S Valve- Twin Hydraulic Plumbing Diagram (PD40087-8S)	15
Hoist Installation Procedure I, Hoist Location on Truck Chassis	16
Hoist Installation Procedure II, Bed Spacer and Rear Hinge Installation	17
Hoist Installation Procedure III, Removing Slack from Hoist and Rear Hinge	18
Hoist and Dump Body Installation Procedure	19
Safety Prop Installation	20-21
CS412TRK Scissor Hoist (A12454)	22-24
CS415TRK Scissor Hoist (A12673)	25-27
CS515TRK Scissor Hoist (A12674)	28-30
CS615TRK Scissor Hoist (A12675)	31-33
Rear Hinge Assembly	34
CS520TRK Scissor Hoist (A12676)	35-37
CS620TRK Scissor Hoist (A12677)	38-40
CS5520TRK Scissor Hoist (A12675)	41-43
CS6620RK Scissor Hoist (A12679)	44-46
CS415LP Scissor Hoist (A12427)	47-49
CS515LP Scissor Hoist (A12428)	50-52
CS615LP Scissor Hoist (A12429)	53-55
CS615HDLP Scissor Hoist (A12557)	56-58
CS620HDLP Scissor Hoist (A12556)	59-61
CS6615LP Scissor Hoist (A12552)	62-64
CS6620LP Scissor Hoist (A12649)	65-67
CS628LP Scissor Hoist (A12554)	68-70
CS5530LP Scissor Hoist (A12553)	71-73
CS6630LP Scissor Hoist (A12547)	74-76
Rear Hinge Assembly	77
Warranty Information	78

Attention: Before Operating, Maintaining, or Repairing the Conversion Hoist read this manual completely and refer to it continuously.

### Safety Alert Symbols

The terms Danger, Warning, and Caution are used to indicate different levels of potential hazard to equipment and personnel.

 **DANGER** Indicates a hazardous situation which, if not avoided, will result in death or serious injury. This signal word is to be limited to the most extreme situations.

 **WARNING** Indicates a hazardous situation which, if not avoided, could result in death or serious injury.

 **CAUTION** Indicates a hazardous situation which, if not avoided, could result in minor injury.

 **NOTICE** Used to warn of a potential hazard to the equipment.

# Safety Checklists



To prevent possible death or injury to personnel and damage to the equipment, the following checklist is to be performed prior to and during operation of the truck and hoist.

## Pre-Operation Checklist

- Prior to initial operation of truck and hoist read this manual completely and refer to it continuously.
- Prior to operation of hoist, read and understand all safety symbols, (cautions, warnings, and dangers) in this manual, identify them on the truck and hoist, and follow their instructions carefully. If any safety symbols are missing or incomplete on the subframe, hoist, or dump body, order them from Godwin Manufacturing.
- Do not allow unauthorized personnel to operate this equipment.
- Do not allow personnel to ride in or on the truck body.
- Do not operate a loaded truck on unlevel or soft surfaces.
- Prior to operation of hoist inspect to ensure that the safety props, pump/valve guard, and PTO shaft guards are in place and in good working order.
- Disengage the PTO drive prior to operating the truck. Moderately high PTO speeds will damage the pump and sustained high PTO speeds may cause the hydraulic oil temperature to rise high enough to damage the pump.

## Operational Checklist

- Before loading the truck make sure that the load does not exceed the Gross Vehicle Weight (GVW) rating of vehicle or the hoist's rated lifting capacity.
- Always load the dump body evenly from side-to-side and from front-to-rear.
- Prior to operating the hoist ensure the area is clear of personnel and equipment.
- Do not allow hoist controls and the area around them to become cluttered with tools, etc.
- Do not operate the hoist under power lines.
- Do not raise the hoist when truck is in motion.
- Do not move the truck with the hoist raised.
- Always release tailgate latching controls prior to lifting the dump body.
- Always operate the hoist controls from inside the truck cab.
- Do not go underneath a loaded and raised truck body under ANY circumstances.
- Do not go underneath a truck with the engine running.
- Do not go underneath an unloaded raised truck body unless the safety props are properly installed.
- Do not leave truck unattended with truck body raised.

## Post-Operation Checklist

- Do not use hands or other body parts to check for hydraulic leaks.
- Follow all Federal, State, and Local regulations pertaining to this equipment.
- Keep all equipment properly maintained and serviced.

# Periodic Inspections

The following checklist is to be followed prior to operating and while operating the truck and hoist:

## Daily Inspection (Before Operating)

- Check hydraulic oil level and add more to the reservoir as needed
  - For PTO driven pumps use HD 32 hydraulic oil
  - For electric driven pumps use Dextron ATF automatic transmission fluid ONLY!
- Check for any fluid leaks under truck and hoist
- Make sure all components are securely fastened, such as frame/pump guard, tool box is closed, hydraulic hoses for spreader/plow properly stowed, etc.
- Check all lighting to be sure it is functioning properly
- Check lighting on any towed equipment
- Inspect hitch if towed equipment is attached and be sure safety chains are fastened
- Test hydraulic functions and observe for proper operations
- Check tire pressure per markings on the tires

## Weekly Inspection

- Perform all of the above checks
- Inspect all mechanical functions, i.e., hoist pivots, rear hinge pivots, single hitch, etc. Be sure they have been properly lubricated and show no signs of stress
- Test low oil shutdown system to be sure it is operating properly

## Bi-Monthly Inspection

- Lubricate all hoist pivot points and rear hinge assemblies with chassis grease (See MP50077)
- Lubricate pintle hitch with chassis grease

## Six Months to One Year (*Depending upon usage*)

- Change hydraulic oil filter (First change should be done after 50 hours of operation)
- Inspect suction strainer in oil tank
- Check hydraulic oil for contamination, discoloration, signs of wear, etc.

# Scissor Hoist Pressure Caution



The chart below provides hoist/hydraulic system specification for all 4", 5" and 6" cylinder units whether used as single cylinder hoist or twin cylinder hoist system applications. The hoist cylinders are designed to operate as single or double acting hydraulic systems.

<b>Single Cylinder Hoist Systems</b>			
<b>Hoist Cylinder Model</b>	<b>GPM Flow (Maximum)</b>	<b>Body Up Pressure</b>	<b>Body Down Pressure</b>
412T, 415T/515T/615T 520T/620T, 628T 412TRK, 415TRK/515TRK/615TRK 415LP/515LP/615LP 615HDLP, 620HDLP 628LP,	8 gallon/minute(max.)	3200 psi Single or Double Acting	0 psi - Single Acting 750 psi - Double Acting

<b>Twin Cylinder Hoist Systems</b>			
<b>Hoist Cylinder Model</b>	<b>GPM Flow (Maximum)</b>	<b>Body Up Pressure</b>	<b>Body Down Pressure</b>
5520T/6620T 6615LP, 5520LP/6620LP 5530LP/6630LP	12 gallon/minute(max.)	3200 psi Single or Double Acting	0 psi - Single Acting 750 psi - Double Acting

# Power Take Off (PTO) and Electric Pump Operations

**WARNING** Disengage PTO before driving truck.

PTO operation is controlled by either a cable, electric hydraulic system, or air shift system. (Refer to Figure 11 below).

## To Engage PTO on Standard Transmission

**NOTICE** The follow instructions are to be performed with the engine running at idle speed, transmission in neutral, and the park brake engaged.

1. Allow the engine to slow to idle speed, shift into neutral, and engage the park brake.
2. Depress and hold down the clutch pedal.
3. Pull PTO control out until the red PTO light illuminates.

**NOTE:** If light does not illuminate, and PTO does not engage. Slowly release the clutch pedal while pulling on the PTO control.

4. When the PTO is engaged, slowly release the clutch pedal to supply power to the hoist pump.
5. The pump/hoist control should be in the neutral or “hold” position.
6. Depress the safety button and pull the pump/hoist control to raise the bed.
7. When bed raises to desired height, push the pump/hoist controls to the center neutral or “hold” position this will stop bed movement up or down.
8. To lower the bed depress the safety button and push pump/hoist control.
9. Depress clutch pedal and push PTO control to disengage.

## To Engage PTO on Automatic Transmission

1. Allow the engine to slow to idle speed, engage the park brake, and shift into a drive gear. This will stop the transmission gears from turning.
2. Shift PTO into gear, then shift transmission into neutral. This will start transmission gears turning, and in turn, put PTO into operation.

## Electric Pump

Press and hold the appropriate button. **Note: Pump will stop when button is released.**

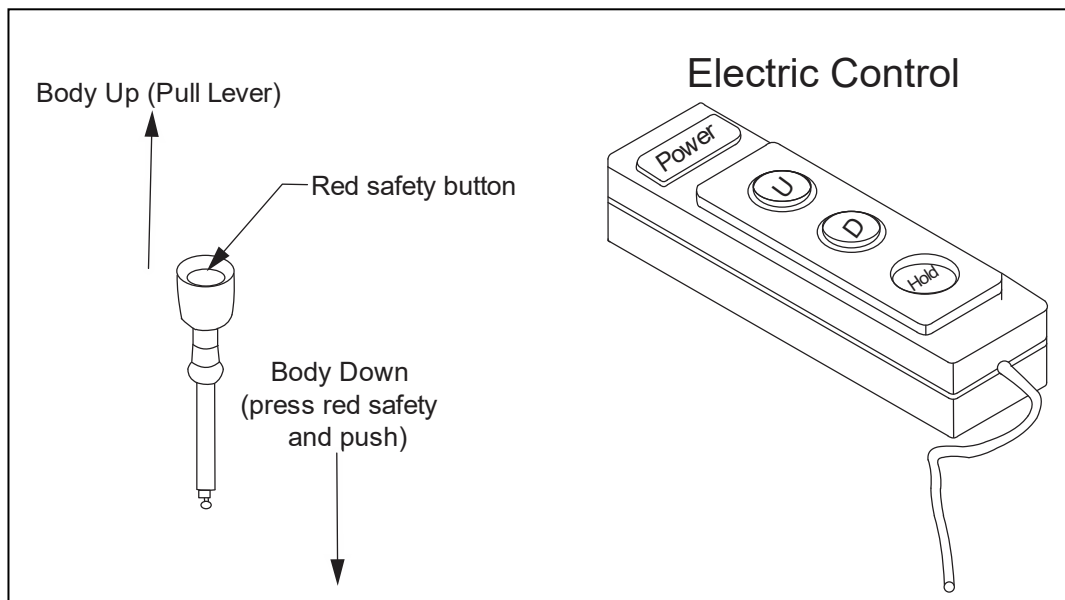
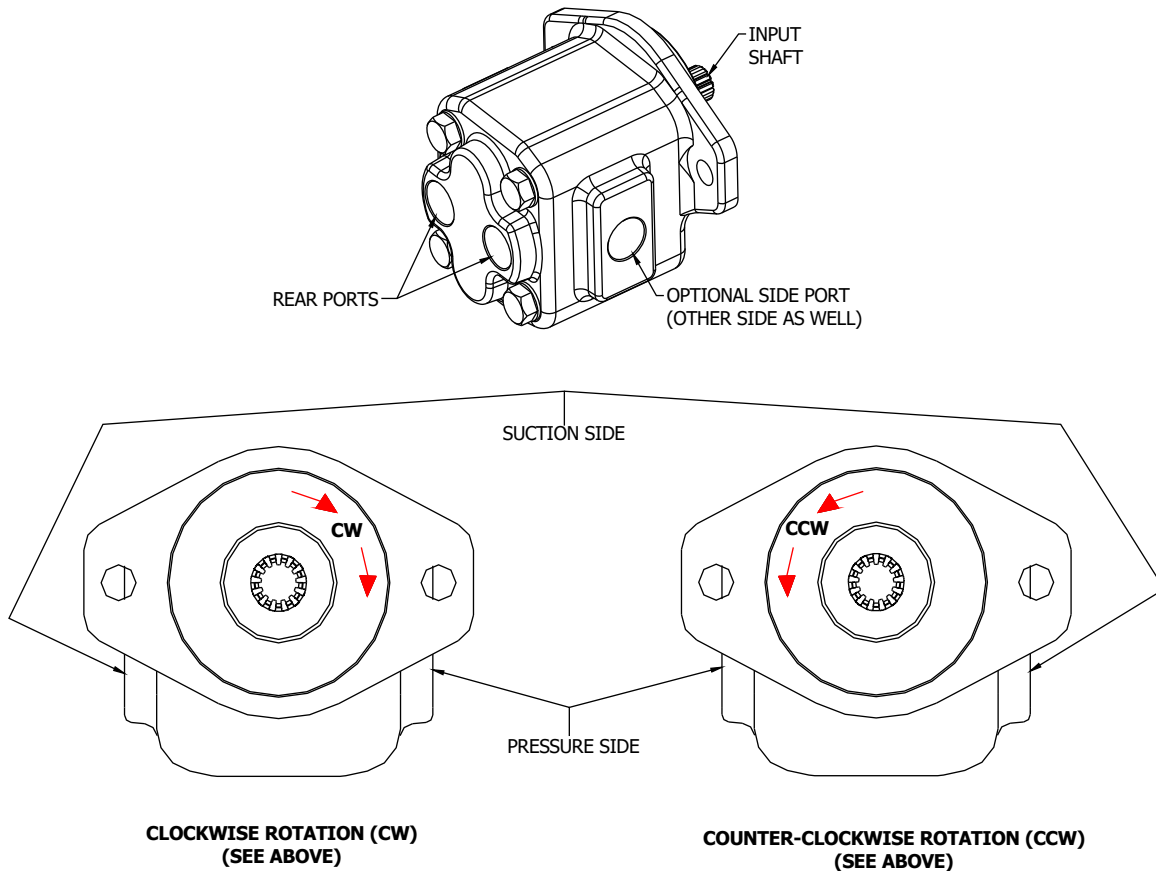

Figure 11: PTO & Electric Pump Controls



# Pump Rotation and Porting



The P21 and P22 pumps are bi-directional and offer side and rear (NPT) porting. The pumps are shipped with the side ports plugged. To utilize side porting move the steel plugs from the side ports to the rear ports and plumb the hydraulic lines. Refer to the illustration above for port designation based on pump rotation.

## Helpful Hint:

To determine pump rotation, do not remove the plastic shipping plugs. Temporarily bolt pump to the mounted PTO. Start truck engine and engage PTO for approximately 3 seconds, then disengage PTO and shut-off engine. The plastic shipping plug on the pressure port should have popped out of the pump housing.

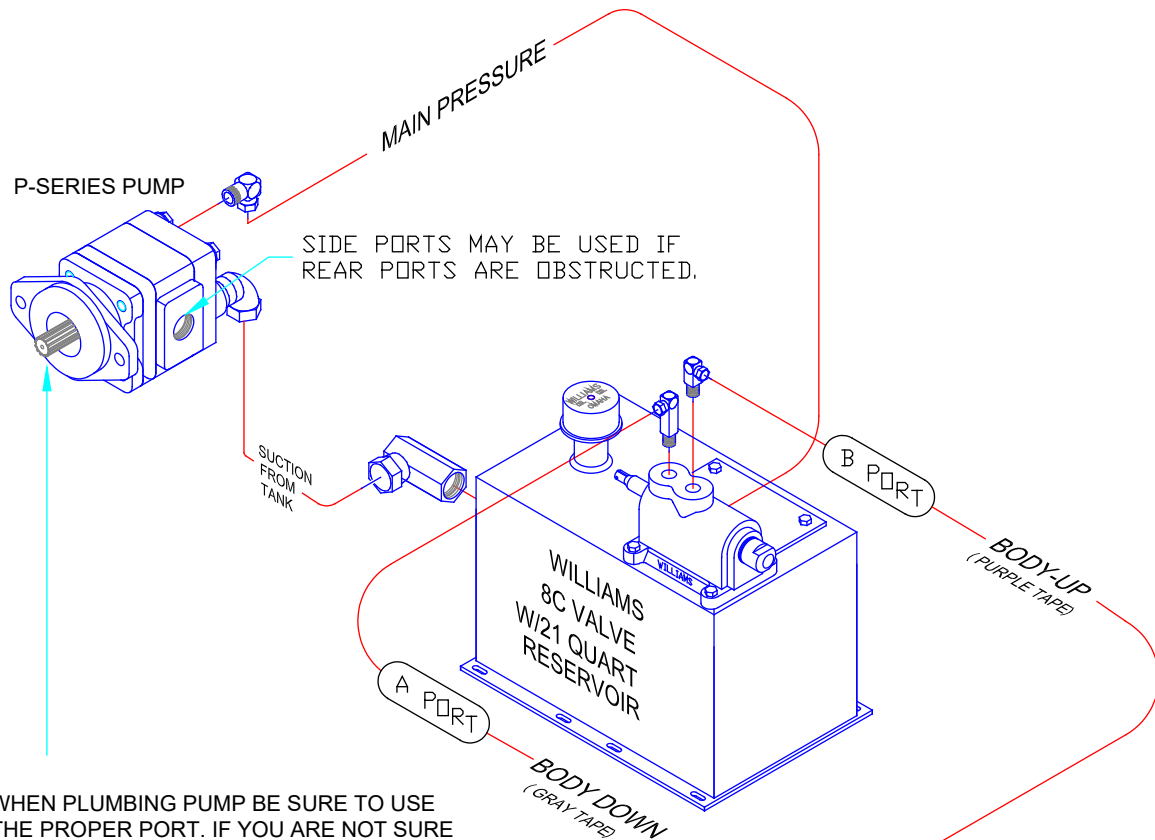

**NOTE:**

WHEN PLUMBING PUMP BE SURE TO USE THE PROPER PORT. IF YOU ARE NOT SURE WHICH PORT IS SUCTION & WHICH IS MAIN PRESSURE. LEAVE SHIPPING PLUGS IN PORTS AND OPERATE PUMP NO LONGER THAN 3 SECONDS THIS WILL POP OUT THE MAIN PRESSURE SHIPPING PLUG. BE SURE IT RUNS NO LONGER THAN 3 SECONDS OR PERMANENT DAMAGE TO PUMP MAY OCCUR!!

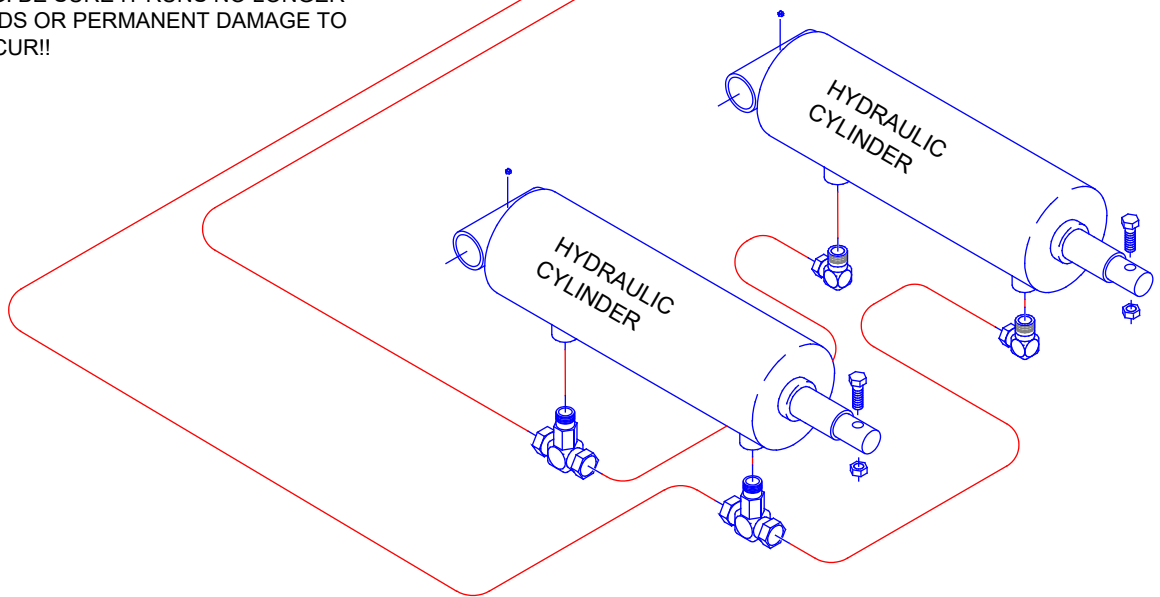

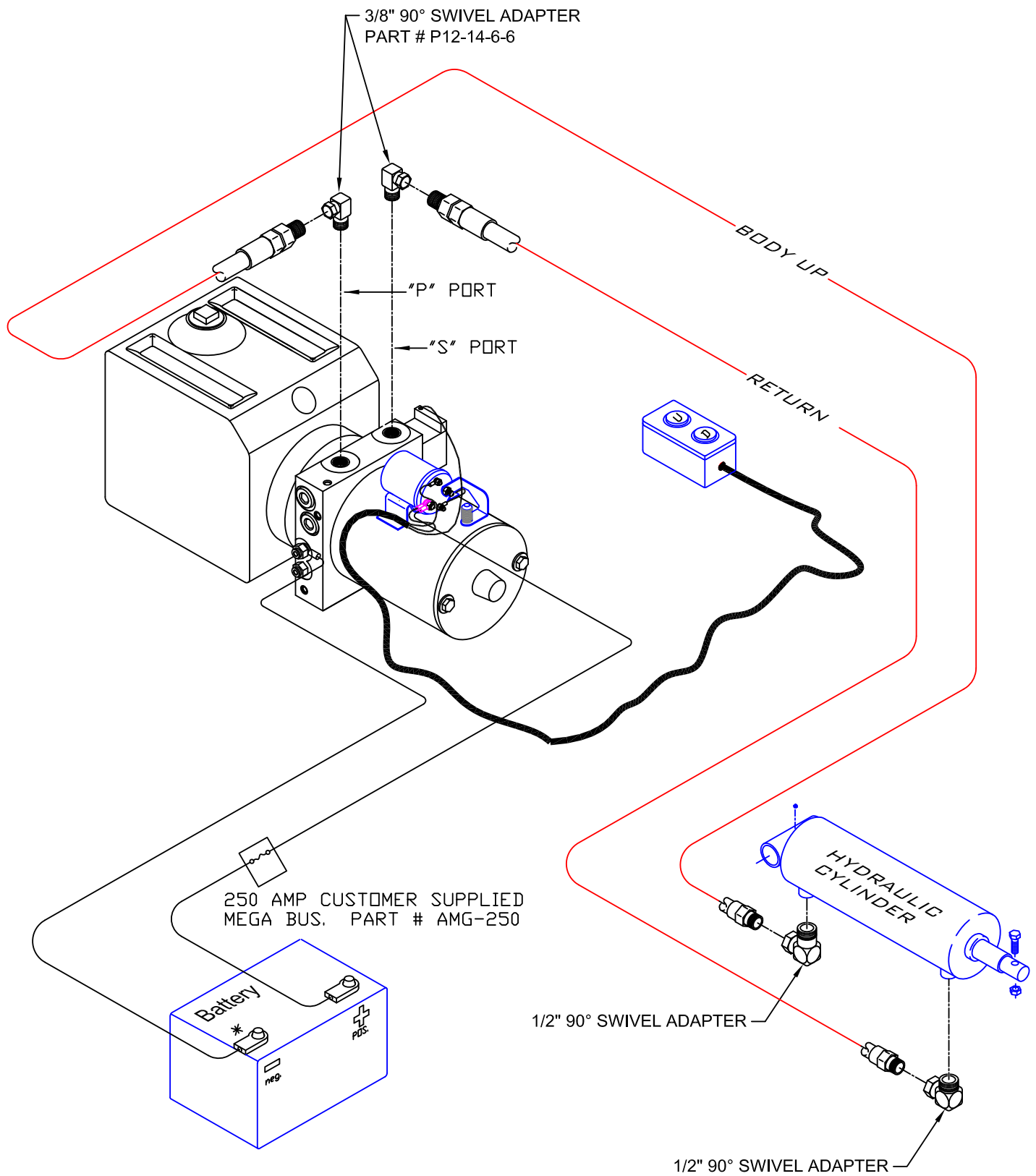

NOTE: Ground Wire is to be ground to valve body.  
DO NOT GROUND TO CHASSIS!!

NOTE:  
HYDRAULIC PORT FITTINGS ORIENTATION MAY  
VARY DEPENDING ON CHASSIS TYPE.

HYDRAULIC PLUMB DIAGRAM  
SINGLE ACTING ELECTRIC PUMP

GODWIN MFG. CO., INC.  
DUNN, NORTH CAROLINA

**PD40048**

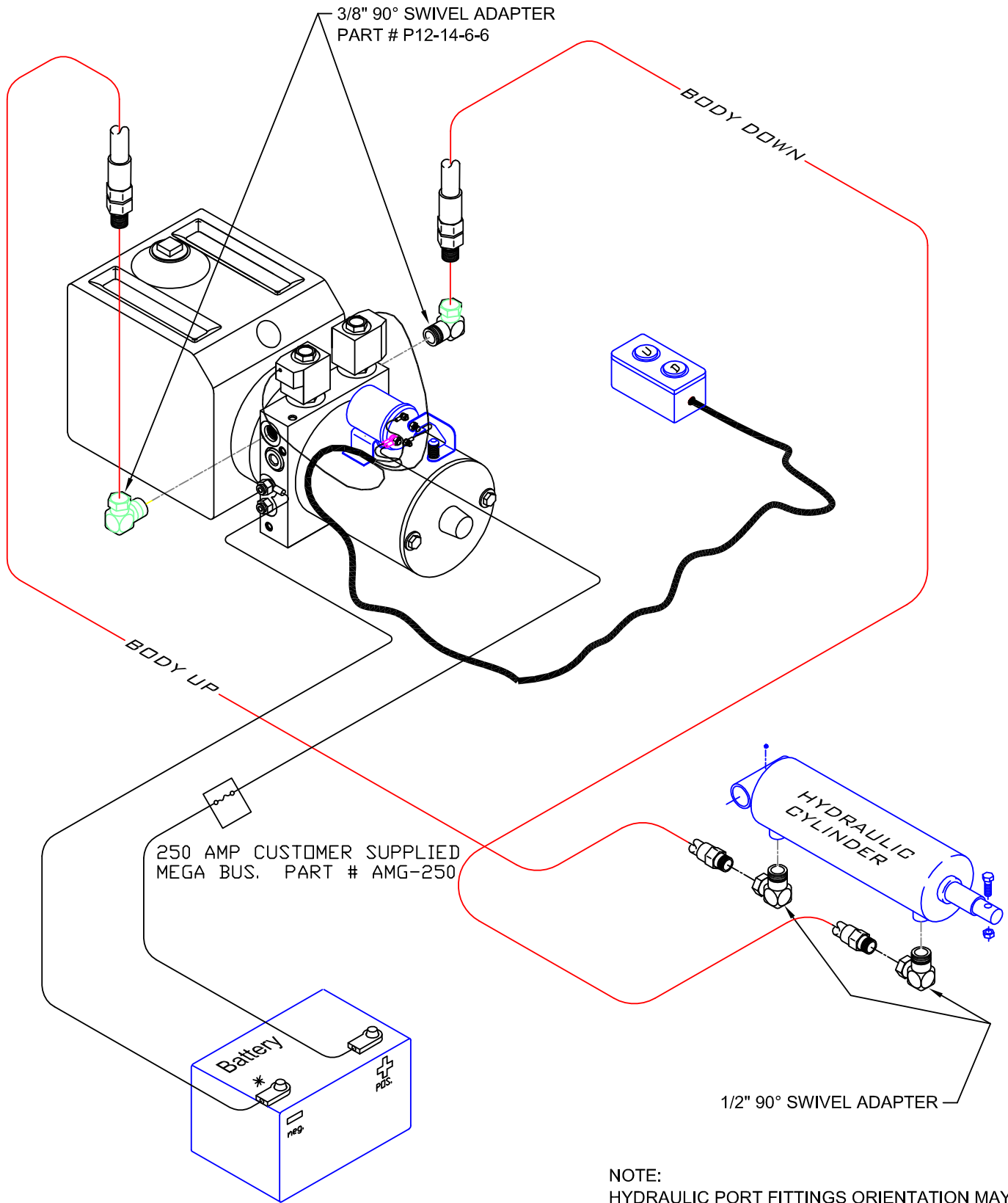

NOTE: Ground Wire is to be ground to valve body.  
DO NOT GROUND TO CHASSIS!!

NOTE:  
HYDRAULIC PORT FITTINGS ORIENTATION MAY  
VARY DEPENDING ON CHASSIS TYPE.

<b>HYDRAULIC PLUMB DIAGRAM DOUBLE ACTING ELECTRIC PUMP</b>	
GODWIN MFG. CO., INC. DUNN, NORTH CAROLINA	<b>PD40045</b>

## Electric Pump Priming Procedure

### Single acting (M-3519) or Double acting (M-3551)

- A. Be sure hoist and electric pump are completely installed and ready to safely operate. Fill electric pump reservoir with Automatic Transmission Oil to within 1 inch of top.
- B. Power the hoist up using the white button the push button controller.

**NOTE:** If hoist does not start to raise within 10 seconds, stop and check that the hydraulic lines are correctly installed. See below:

- Monarch 3551 (double acting, yellow) “C1” port = hoist raise (white button) = 3200 PSI.  
“C2” port = hoist lower (black button) = 800 PSI.
- Monarch 3519 (single acting, orange) “P” port = hoist raise (white button) = 3200 PSI.  
“S” port = lower/vent to res (black button) = 0 PSI.

**NOTICE** To prevent damage to the equipment, Do not allow the hydraulic reservoir to run out of hydraulic, Automatic Transmission Oil. Always maintain at least half a tank of oil.

- C. When powering the hoist up the first time, it is imperative that the reservoir NOT run out of oil. Maintain a half tank of oil on the first lift by stopping and filling as needed.
- D. Check for leaks during lifting operations and check for obstructions.
- E. For double acting pump only- Lower the hoist by pressing the black button.  
**Note:** Lower the hoist 1/3 and stop for 20 seconds, repeat two more times until hoist is fully lowered. Once the hoist has fully lowered CONTINUE to hold the black button until the oil in the reservoir stops moving (turbulence), about 20 seconds. The turbulence in the reservoir during this crucial step is filling the top side (or down side) of the cylinder. This typically has to be done only upon the initial installation or when the unit has run low in oil and is being refilled.
- F. After steps A through E have been done, fill the reservoir as needed to maintain  $\frac{2}{3}$  to  $\frac{3}{4}$  full with the bed down.

#### Helpful Hints:

1. Perform the above priming steps no more than twice in 30 minutes due to oil aerating.
2. If the reservoir overflows when lowering, the following could cause overflowing.
  - (a) Aerated oil
  - (b) “Hoist lower” line too small or obstructed
  - (c) Wrong ports used on pump
  - (d) Extremely cold conditions.
3. Make sure the customer understands that the electric power unit (used when necessary) has the same lifting capacity but will be slower than a PTO driven unit.
4. Do not operate pump more than two minutes at a time or without truck engine running so as to keep a charge in battery.

## Electric Pump Troubleshooting Procedure Single acting (M-3519) or Double acting (M-3551)

### Electric pump solenoid does not click:

A. Bad hot (+) or ground (-) cables(s) from battery to pump. Be sure to use both cables and connect directly to the battery. Install a 250 amp mega fuse at the positive battery connection.

**NOTE:** On newer trucks, the ground cable from battery to chassis is too small to carry the load of the electric pump unit. Two individual positive and ground cables from battery to electric pump unit are needed to correct for the higher current draw.

B. Check for 12 volt signal at small post of solenoid when pressing the up button on the control. If voltage is below 12 volts it may be an alternator or battery issue. If no voltage, it may be the switch or a broken or corroded wire.

### Electric pump Solenoid clicks but motor does not operate:

A. Check battery connection between solenoid and motor

B. Contacts in solenoid could be burned. (Check this by shorting the two large posts on the solenoid, if motor turns replace solenoid assembly)

C. Bad motor

D. Seized pump

### Motor/pump turns but hoist will not work:

A. Check for 12 volts at valve coil(s). Could be bad switch or broken wire.

B. Are coils magnetized when button is pressed? Could be bad coil or connector.

C. Cartridge stem could be bent. Lower bed completely, remove cartridge, and roll it on a table to check for alignment.

D. Check pump unit pressure. Up pressure should be 3200 PSI and down (on double acting units) should be 800 PSI.

### Hoist stuck in Up position, will not come down:

A. Check for 12 volts at down coil.

B. Check for bent stem on down cartridge. Call for service technician.

**DO NOT ATTEMPT TO REPAIR!**



**A hoist that is stuck in the up position is an extremely dangerous situation and must be handled with great care. DO NOT ATTEMPT TO REPAIR! Contact a service technician.**

**Note:**

Install a 10 amp fuse at the source. Fuse provided by others.

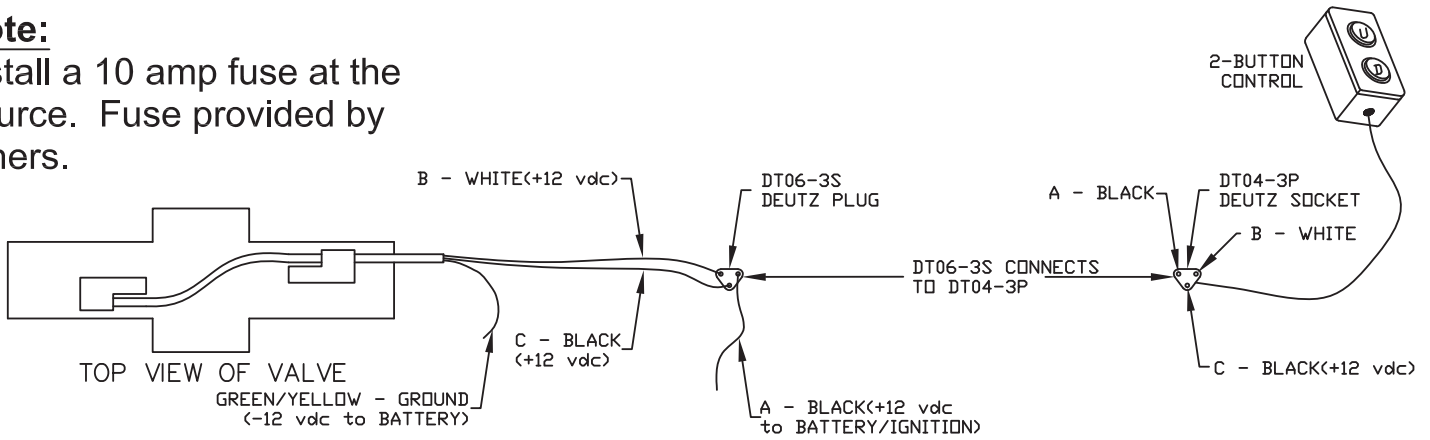

**WIRING DIAGRAM**

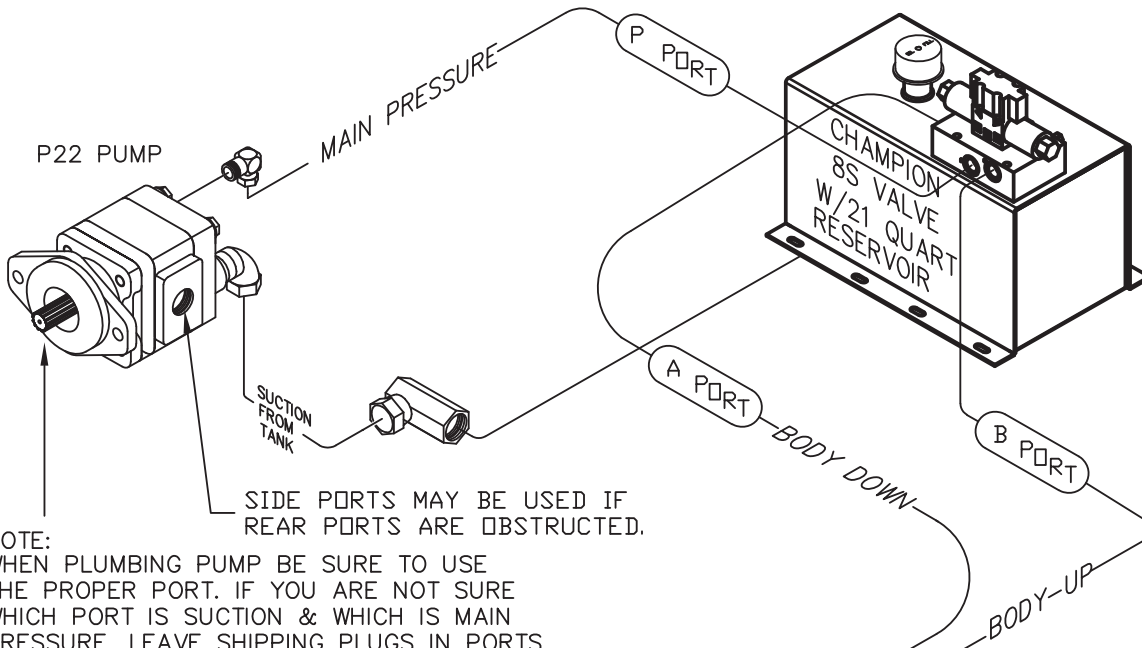

NOTE:  
 WHEN PLUMBING PUMP BE SURE TO USE THE PROPER PORT. IF YOU ARE NOT SURE WHICH PORT IS SUCTION & WHICH IS MAIN PRESSURE. LEAVE SHIPPING PLUGS IN PORTS AND OPERATE PUMP NO LONGER THAN 3 SECONDS THIS WILL POP OUT THE MAIN PRESSURE SHIPPING PLUG. BE SURE IT RUNS NO LONGER THAN 3 SECONDS OR PERMANENT DAMAGE TO PUMP MAY OCCUR!!

**Factory Pressure Presets**

High Pressure Valve(Red)  
 Up - 3200 psi  
 Down - 750 psi

**NOTE:**

TWIN CYLINDER APPLICATION ARE FOR 4"/5"/6" DIAMETER CYLINDERS ONLY

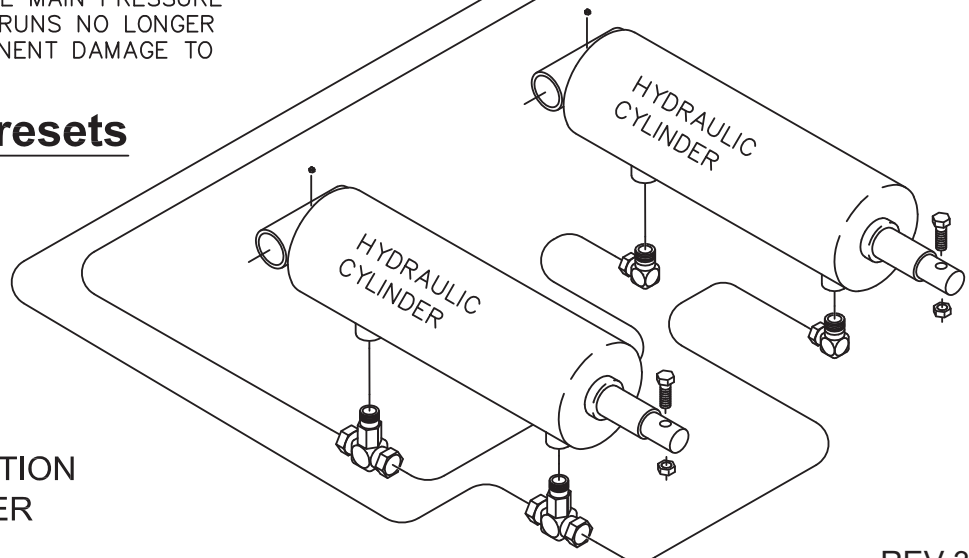

REV 3-10-21

**HYDRAULIC PLUMBING DIAGRAM**

**CHAMPION 8S VALVE- TWIN HYDRAULIC PLUMBING DIAGRAM**

GODWIN MFG. CO., INC.  
DUNN, NORTH CAROLINA

**PD40087-8S**

## Procedure I - Hoist Location On Truck Chassis

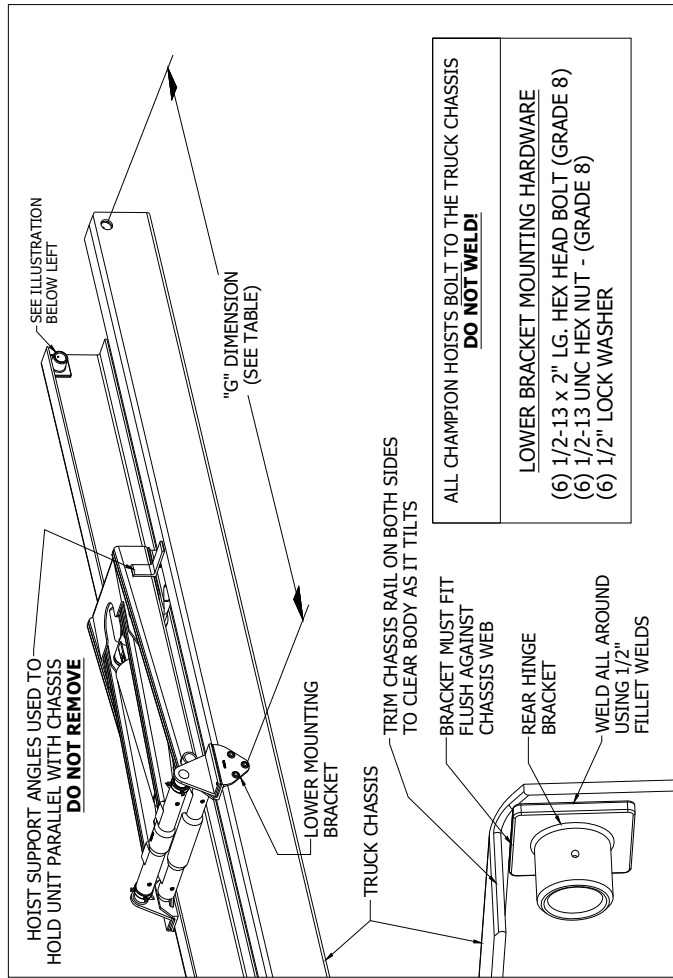

Model	45° Tilt	50° Tilt
CS412TRK	62.5	56.5
CS415TRK	76"	69"
CS515TRK	76"	69"
CS615TRK	76"	69"
CS415LP	76"	68.5"
CS515LP	76"	68.5"
CS615LP	76"	68.5"
CS615HDLP	82"	74"
CS620HDLP	105"	95"
CS6615LP	82"	74"
CS6620LP	106.5"	96.5
CS628LP	132"	119.5"
CS5530LP	138"	125"
CS6630LP	138"	125"

### Procedure Steps:

(Refer to illustration on this page)

Locate and mark Centerlines for the Rear Hinge Pivot. (This dimension is usually 6" behind the Rear Spring Hanger Bracket but may vary on certain chassis models.)

Based on the hoist model, select the "G" dimension from the table above. Mark the Centerline of the Lower Mounting Bracket.

Place the hoist on the chassis and check for Crossmember interference. The hoist may be repositioned fore or aft to relieve any interference with truck components.

After successful hoist location, drill truck chassis and mount the Lower Mounting Brackets using approved hardware as shown on the illustration.

GWWR	Hoist Model	Recommended Bed Length
8,000 - 10,000 LBS.	CS415LP	10 - 12 FT.
8,000 - 10,000 LBS.	CS515LP	10 - 12 FT.
11,000 - 14,000 LBS.	CS615LP	10 - 12 FT.
11,000 - 15,000 LBS.	CS615LP	10 - 12 FT.
14,000 - 18,000 LBS.	CS615HDLP	10 - 12 FT.
18,000 - 24,000 LBS.	CS6615LP	12 - 14 FT.
14,000 - 18,000 LBS.	CS620HDLP	12 - 16 FT.
24,000 - 28,000 LBS.	CS628LP	12 - 16 FT.
24,000 - 28,000 LBS.	CS6620LP	14 - 16 FT.
28,000 - 35,000 LBS.	CS5530LP	18 - 22 FT.
35,000 - 50,000 LBS.	CS6630LP	18 - 24 FT.



## Procedure II - Bed Spacer and Rear Hinge Installation

### **Procedure Steps:** (See Illustrations Left)

Cut Spacer Blocks (1" x 3" x 4" LG).

Position blocks on top of the Truck Chassis Rail on either side of the Lower Hoist Mounting Brackets approximately 48" apart. The 1" thick side should face up on the Long Sill.

Place Dump Body on Truck Chassis approximately 2-1/2" from Truck Cab. The body must be parallel with the chassis rails.

Weld Rear Hinge Flippers to Long Sills. Using 1/2" continuous Fillet Welds around all contact areas.

Weld Body Spacers to long sills of the dump body.

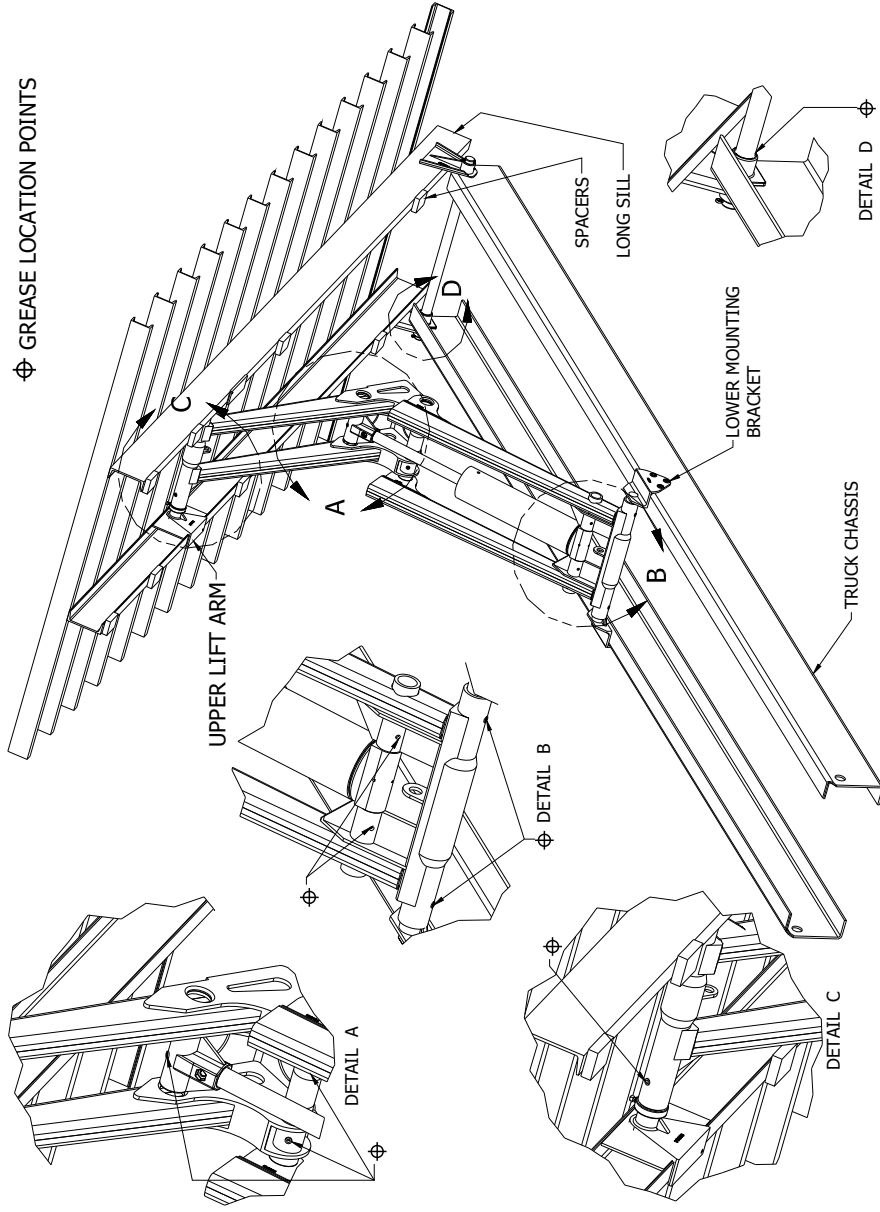

### **CAUTION**

Failure to perform this procedure as specified could cause hoist failure and therefore **VOIDS ASSOCIATED WARRANTY!**

**PROCEDURE III - REMOVING SLACK FROM HOIST AND REAR HINGE**

**INCORRECT INSTALLATION**

**UPPER LIFT ARMS AND TOP OF LONG SILLS MUST BE PARALLEL.**

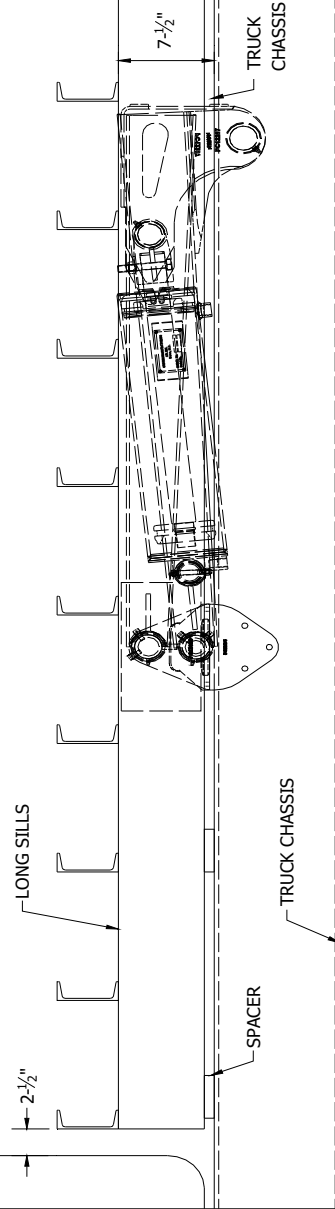
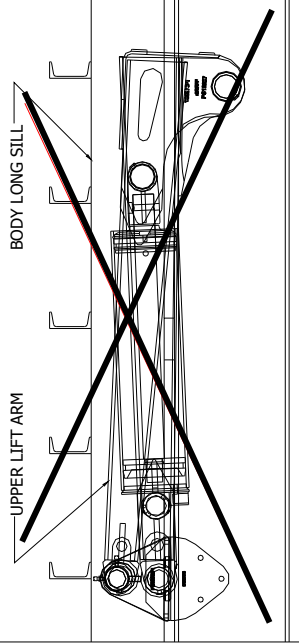

**NOTE: MAKE SURE TO GREASE ALL LUBRICATION FITTINGS BEFORE OPERATING. REFER TO PAGE (8) FOR FITTING LOCATIONS.**

**PROCEDURE STEPS:**  
(SEE ILLUSTRATION LEFT)

- SIT THE BODY FLUSH ONTO THE TRUCK CHASSIS.
- WELD LIFT ARMS TO LONG SILLS USING 1/2" CONTINUOUS FILLET WELD. (SEE BELOW)
- MAKE SURE HOIST IS CENTERED WITHIN THE TRUCK CHASSIS RAILS.
- SLIDE THE HOIST SET COLLARS FIRMLY AGAINST THE LIFT ARM SHOULDERS AND TIGHTEN THE SQUARE HEADED SCREWS.

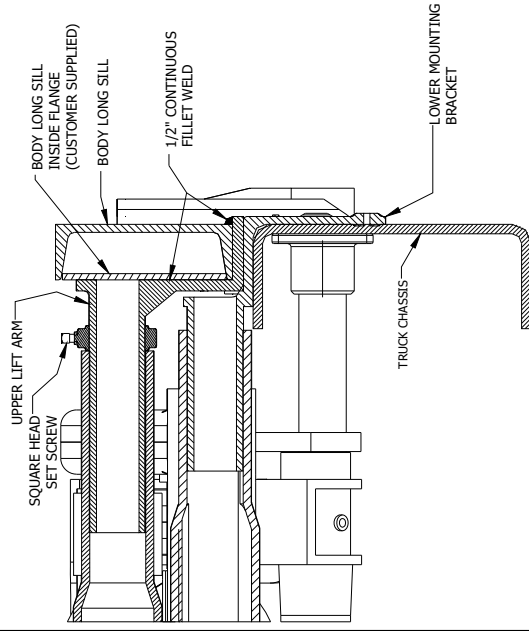

**CAUTION:** FAILURE TO PERFORM THIS PROCEDURE AS SPECIFIED COULD CAUSE HOIST FAILURE AND THEREFORE VOIDS ASSOCIATED WARRANTY.

# Hoist and Dump Body Installation Procedure

## Install Hoist Assembly

### Determine Hoist Location and Install Hoist

1. Measure 3 inches from the rear of the truck cab along the chassis and mark the distance with a bright marker pen.

**NOTICE** The 3 inch distance will not apply if there is an obstruction on the back of the cab or the chassis. If there is an obstruction, measure 3 inches from the obstruction towards the rear of the chassis or remove the obstruction.

2. Measure and record the distance from the 3 inch mark to the end of the truck chassis.
3. Measure and record the length of the long sill on the bottom of the dump body.
4. Determine amount of chassis to remove based on measurements taken and desired overhang.
5. Once the correct distance is determined, cut a notch into the ends of the chassis rails to accommodate the rear hinge flipper assembly and remove any excess rails.
6. Align the rear hinge flipper assembly in the notches and install it with a 1/2 inch continuous fillet weld on all contacting surfaces between the chassis rails and the rear hinge flipper assembly.
7. Using an appropriate lifting device, i.e., overhead crane, place the hoist on the chassis and check for crossmember interference. The hoist may be repositioned fore or aft to relieve any interference with truck components.
8. Locate and mark centerline for rear hinge pivot.
9. Based on the hoist model, select the "G" dimension from the table associated with the hoist.
10. Mark the centerline of the lower mounting bracket on the hoist assembly.
11. After successful hoist location, drill truck chassis and mount the lower mounting brackets using approved hardware.
12. Connect hydraulic lines to hoist and use the hoist controls to raise and lower the hoist to test operation of the hoist.

## Install Dump Body

**DANGER** Dump bodies are very heavy! Be careful when lifting or moving.

### Determine Body Location and Install Body

1. Using an appropriate lifting device i.e., overhead crane, place the body on the chassis and check for correct alignment with chassis. Be sure that the body is aligned with the measurements in step 1.
2. Using the hoist controls, raise the hoist until upper lift points are flush against cross sill, but not high enough to lift the body.
3. Tack weld rear hinge flippers and upper lift points enough to allow the body to be raised safely.
4. Using the hoist controls, raise the body high enough to engage the safety prop.
5. Securely weld rear hinge flippers and upper lift points to the body.
6. Allow welds to cool and grease all pivot points and grease fittings with EP-2 chassis grease or equivalent. (Refer to hoist dimensions, capacities, & parts pages for grease fitting locations.)

## Safety Prop Installation

Federal Regulation 1926.601, paragraph 10, requires the use of a Safety Prop (Safety Strut or Body Prop) on Dump Trucks and Dumping Trailers.



- Do not place any personal body parts between the truck chassis and the moving parts of the hoist and dump body.
- Do not use the safety prop when the dump body is loaded.
- Do not use damaged, bent, or loose safety props. Replace if damaged or bent and tighten all loose bolts.
- Read and understand the safety labels accompanying the safety prop. If label is damaged or missing, replace with a new label.

### Safety Prop Information

1. Safety prop is not designed to be used when the dump body is loaded. It is designed to be used only when the body is empty and needs cleaning, inspecting, or maintenance.
2. Godwin hoists are equipped with a single safety prop for dump bodies below 13 feet in length, and two safety props for dump bodies above 13 feet in length.
3. To prevent damage to safety prop and other equipment, keep safety prop stowed in prop mounting bracket when not in use.

### Using the Safety Prop

1. Use the hoist controls to raise the dump body high enough to stand the safety prop up.
2. Align the safety prop with the safety cup and slowly lower the dump body down.
3. When the safety prop is no longer required. Use the hoist controls to raise the dump body high enough to clear the safety prop and lower the safety prop down into a safe position.

### Safety Prop & Cup Installation

**Note: The following instructions are for single safety prop trucks. Extra care must be taken when locating dual safety props to prevent drilling into a hydraulic hose or an electrical wire.**

1. Use the hoist to raise the dump body high enough to allow for measurement of correct alignment of safety prop and cup. Leave body raised until installation is complete.

**Note: The safety prop cup must be located on a dump body cross channel. This means that the cup will be tucked-up inside of the dump body so that it can be welded to the cross channel, and the floor of the body.**

**Note: When correctly installed the safety prop will angle slightly (80°) towards the rear of the truck. Put another way, 90° is perpendicular (vertical) to the truck frame therefore 80° is 10° off of vertical. This will prevent the safety prop from slipping out of the safety cup.**

2. Assemble the safety prop and pivot bracket by inserting a ½ inch bolt through the bracket and the prop. Secure it lightly with a nut.
3. Align the pivot bracket even with the top of the truck chassis and tip the safety prop 80° towards the rear of the truck. Slide the bracket and prop assembly along the chassis until the location of the safety cup is determined.

Prior to locating the safety cup and prop carefully inspect the area for any wiring or hydraulic hoses.

**NOTICE** Pay particular attention to the inside of the chassis where the two holes for the pivot bracket will be drilled. Temporarily move any wiring or hoses out of the way when drilling.

## Safety Prop Instructions (continued)

### Safety Prop & Cup Installation (continued)

4. Mount the safety cup to the cross member, and underside of the floor. Secure it with a C-clamp and weld all contact points with 3/8 inch bead.
5. Place the end of the safety prop in the newly mounted safety cup (at the 80° angle) and mark the location for the holes to be drilled into the truck chassis.
6. Disassemble the safety prop and pivot bracket by removing the 1/2 inch bolt holding the bracket and the prop together.
7. Align the pivot bracket to the mark on the chassis and remark the holes.
8. Remove the pivot bracket and drill the two holes. (refer to notice above)
9. Mount the pivot bracket to the chassis with the lower bolt and assemble the safety prop to the pivot bracket and chassis using the longer bolt.
10. Tighten the lower (shorter) bolt firmly to the chassis and tighten the upper (longer) bolt enough to allow the safety prop to move back and forth, with effort.
11. Align the safety prop with the safety cup and rest the body on the safety prop and test for stability. (The safety prop should not move and should stay in the safety cup.)
12. Lift body off of safety prop and check tightness of bolts.
13. Lower safety prop forward alongside the chassis and lower body fully.

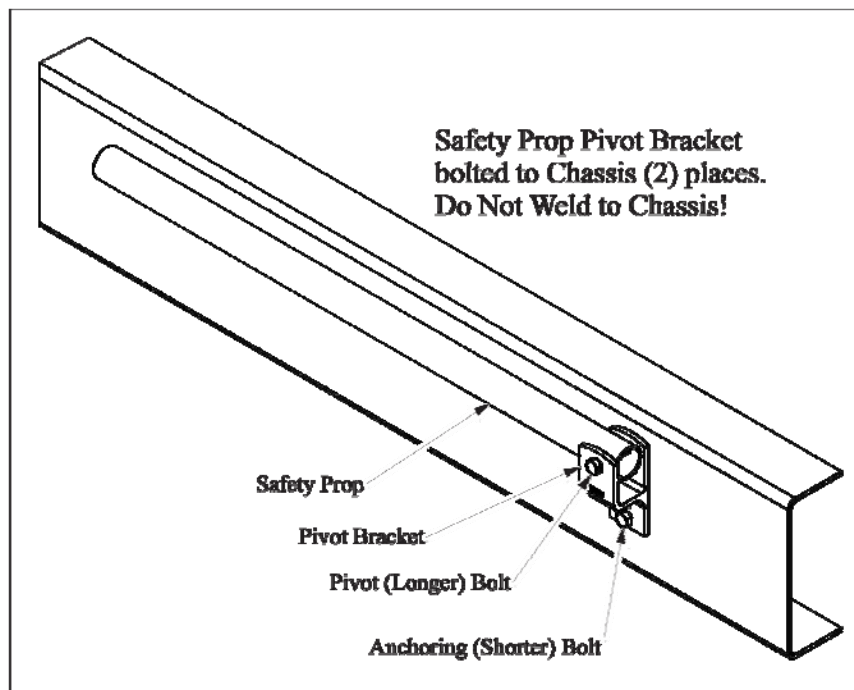

Safety Prop Installation

## CS412TRK Capacities

CS412TRK Hoist Capacity (Tons)			
Body Length (Feet)	Overhang (Inches)	Dump Angle (Degrees)	
		"G" Dimension (Inches)	
		45 Deg.(62.5 Inches)	50 Deg. (56.5 Inches)
8	0	5.10	4.60
	12	6.80	6.10
	18	8.10	7.30
	24	10.20	9.20
9	0	4.50	4.10
	12	5.80	5.20
	18	6.80	6.10
	24	8.10	7.30
10	0	4.10	3.70
	12	5.10	4.60
	18	5.80	5.20
	24	6.80	6.10

# CS412TRK Dimensions

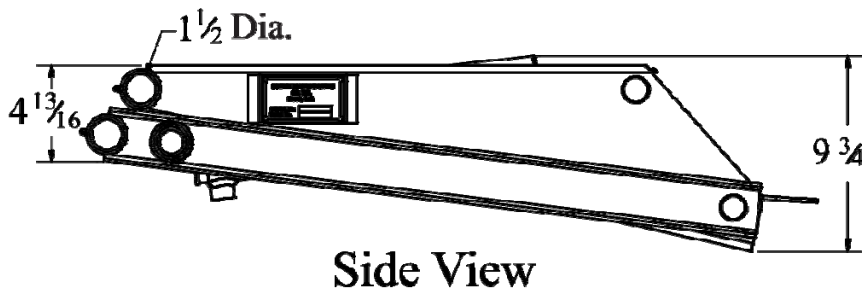
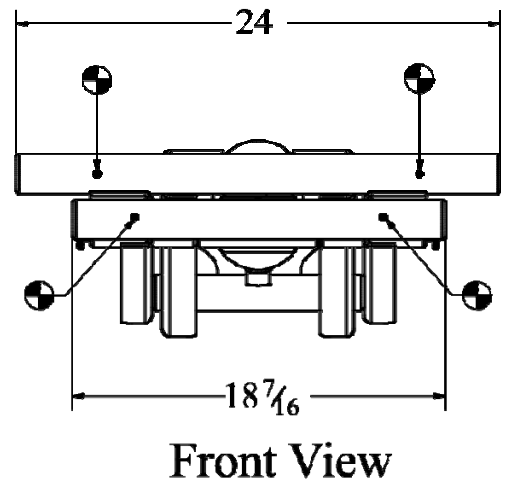
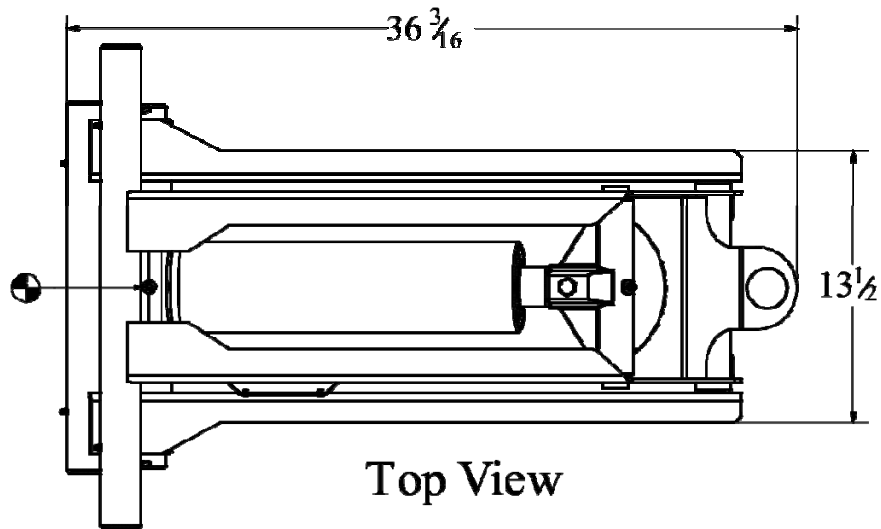

 Grease Fitting Locations

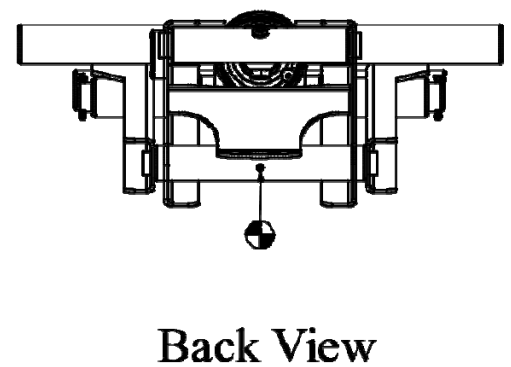
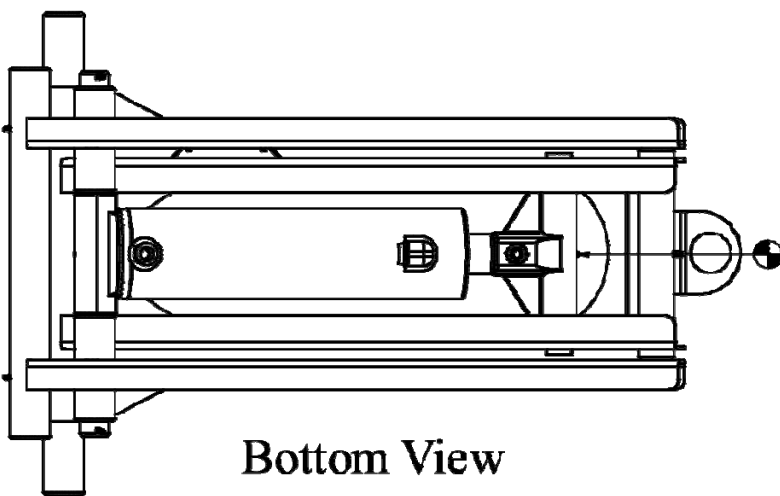

# CS412TRK Parts List

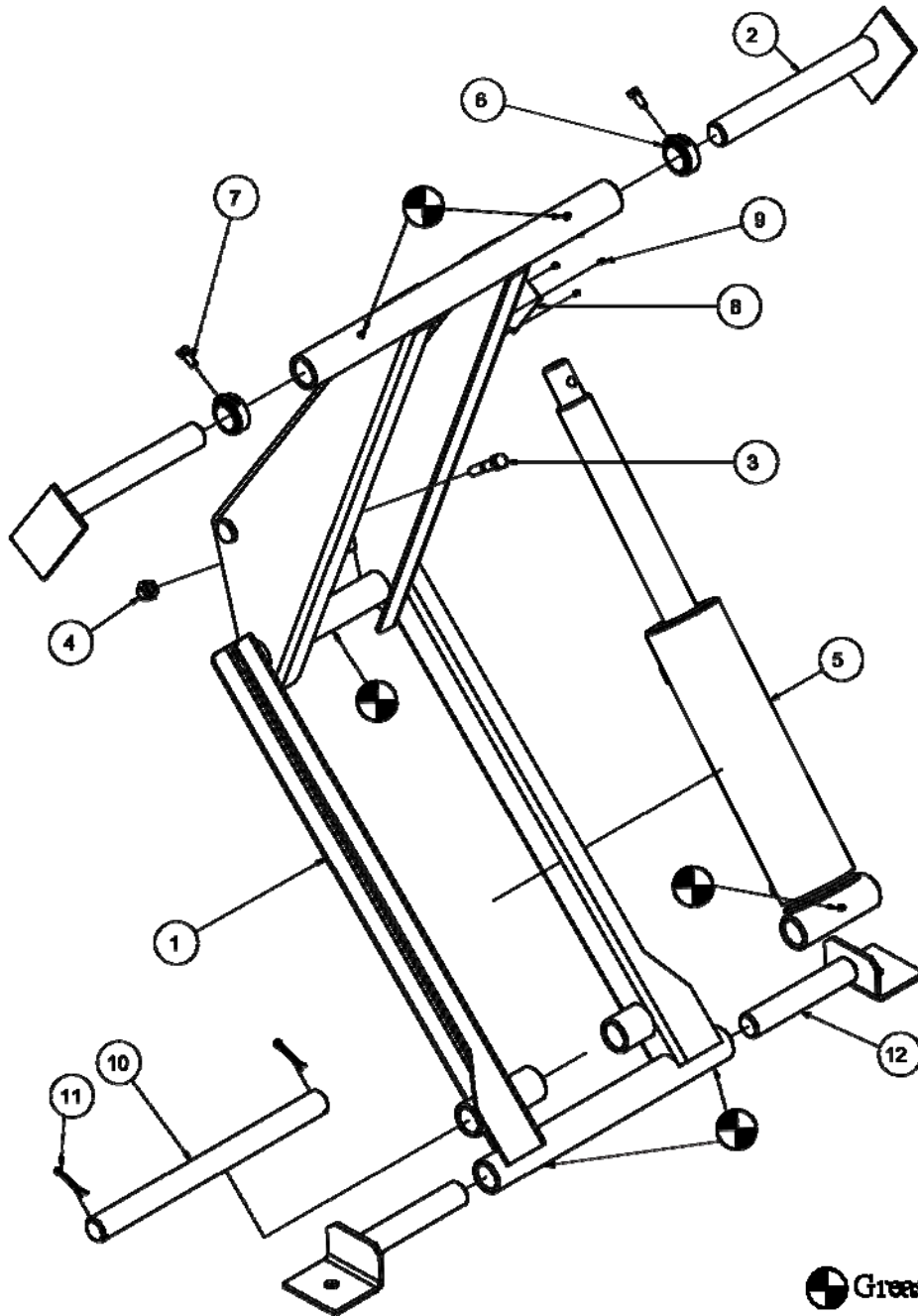

 Grease Fitting Locations

CS412TRK Parts List (refer to engineering drawing A12454)

Item	Qty.	Part Number	Description
1	1	W12439	Scissor Hoist Weldment, CS412T
2	2	W12451	Upper lift Arm Weldment, CS412T
3	1	102-411-A1	Hex Bolt, 1/2" x 2 1/2"
4	1	162-10-S	Lock Nut, 1/2"
5	1	A21324	Cylinder Assembly 412
6	2	PC12458	Collar, Lift Arm 1-7/16"
7	2	P34	Set Screw 3/8"-16 x 3/4" Square Head
8	1	P10100	Serial Plate
9	4	PAAP43	Rivet, 1/8" Cherry Pop
10	1	SM12580	Bottom Cylinder Shaft, 412T
11	2	125-256	Pin, Cotter
12	2	W12582	Lower Lift Point Weldment 412T



## CS415TRK Capacities

CS415TRK Hoist Capacity (Tons)			
Body Length (Feet)	Overhang (Inches)	Dump Angle (Degrees)	
		"G" Dimension (Inches)	
		45 Deg.(76 Inches)	50 Deg. (69 Inches)
8	0	6.20	5.60
	12	8.20	7.50
	18	9.90	9.00
	24		11.20
9	0	5.50	5.00
	12	7.10	6.40
	18	8.20	7.50
	24	9.90	9.00
10	0	4.90	4.50
	12	6.20	5.60
	18	7.10	6.40
	24	8.20	7.50

# CS415TRK Dimensions

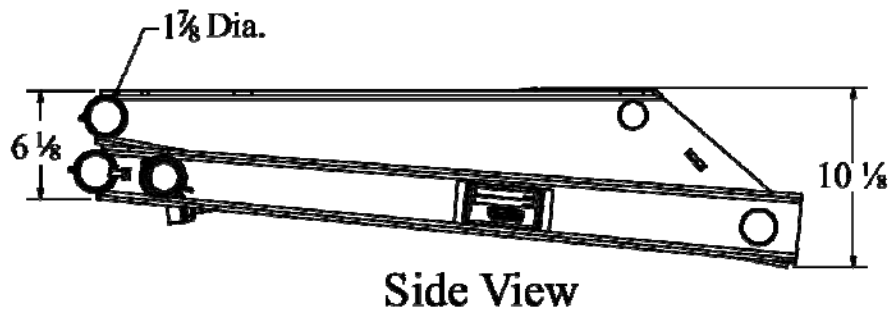
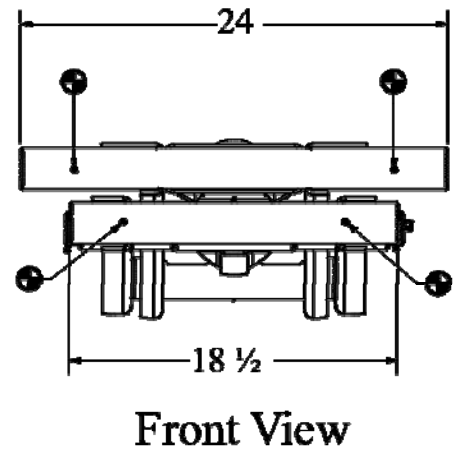
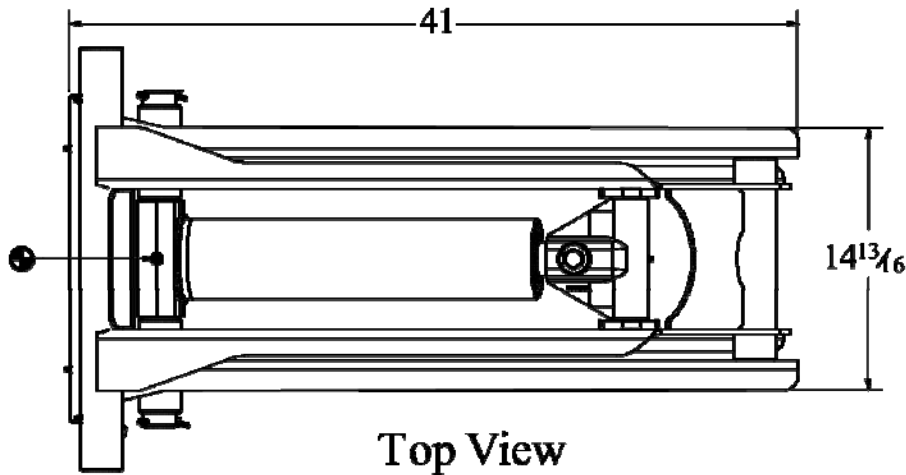

 Grease Fitting Locations

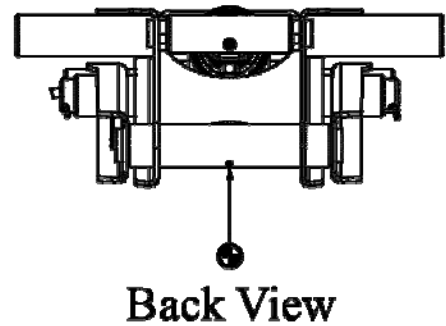
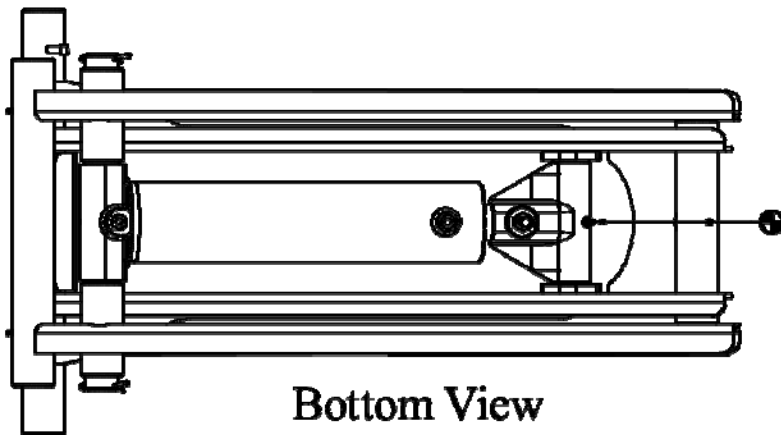

# CS415TRK Parts List

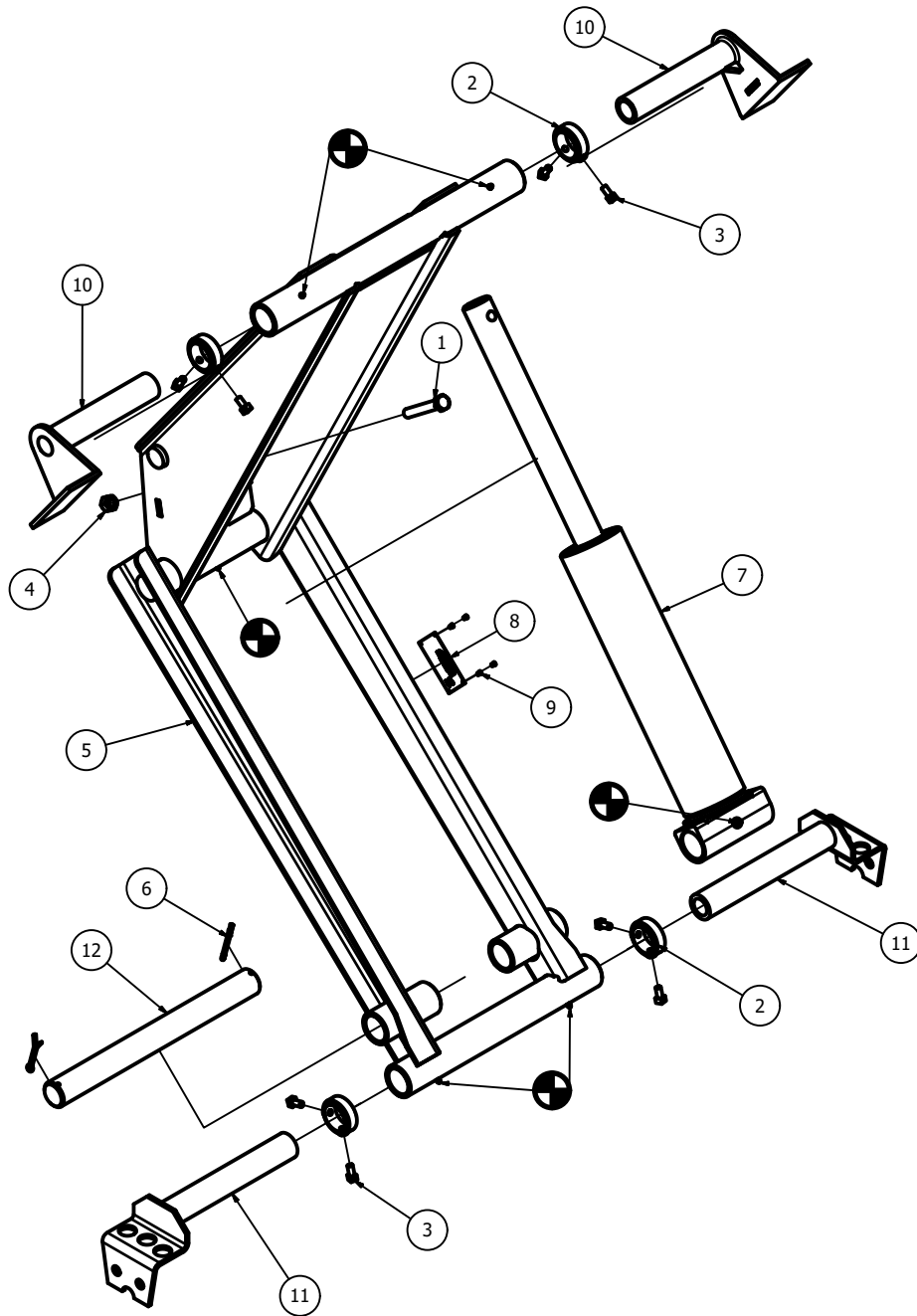

PARTS LIST			
ITEM	QTY	PART NUMBER	DESCRIPTION
1	1	102-617-L	Hex Cap Screw, 5/8 x 4, GR 9
2	4	PC12161	COLLAR, LIFT ARM 1-7/8"
3	8	P34	SET SCREW 3/8"-16 x 3/4" SQHD
4	1	143-7	5/8" NYLON LOCK NUT
5	1	W12334	SCISSOR HOIST WELDMENT, 415T/515T/615T
6	2	125-259	COTTER PIN, 1/4 x 2 1/2
7	1	A21321	ASSEMBLY, 415 DA CYLINDER
8	1	P10200	CHAMPION SERIAL PLATE
9	4	PAAP43	RIVET, 1/8" CHERRY POP
10	2	PC10627	UPPER LIFT ARM, 1-7/8"
11	2	W12352	1 7/8 LOWER LIFT ARM WELDMENT
12	1	PC12651	BOTTOM CYLINDER SHAFT, 415/515/615/615LS415T/515T/615T

# CS515TRK Capacities

CS515TRK Hoist Capacity (Tons)			
Body Length (Feet)	Overhang (Inches)	Dump Angle (Degrees)	
		"G" Dimension (Inches)	
		45 Deg.(76 Inches)	50 Deg. (69 Inches)
9	0	8.60	7.80
	12	11.00	10.00
	18	12.90	11.70
	24	15.40	14.00
10	0	7.70	7.00
	12	9.70	8.80
	18	11.00	10.00
	24	12.90	11.70
11	0	7.00	6.40
	12	8.60	7.80
	18	9.70	8.80
	24	11.00	10.00

# CS515TRK Dimensions

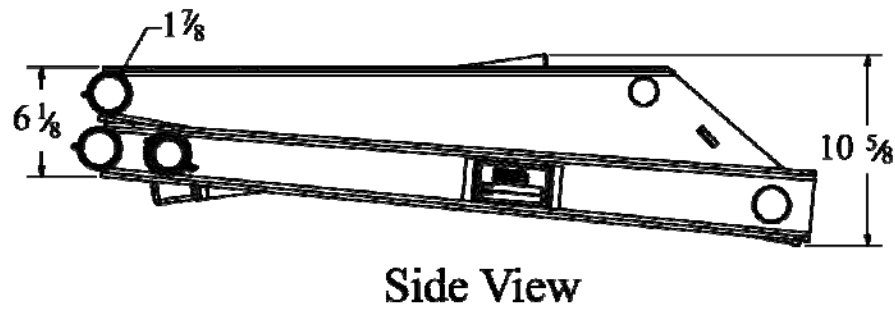
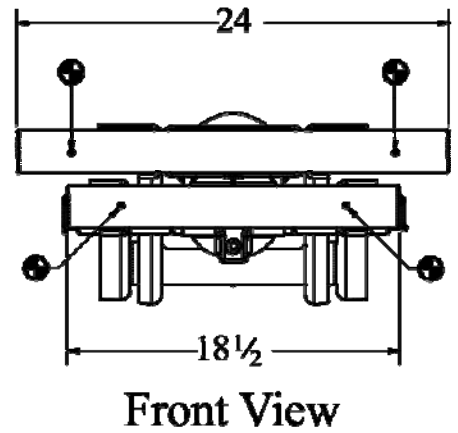
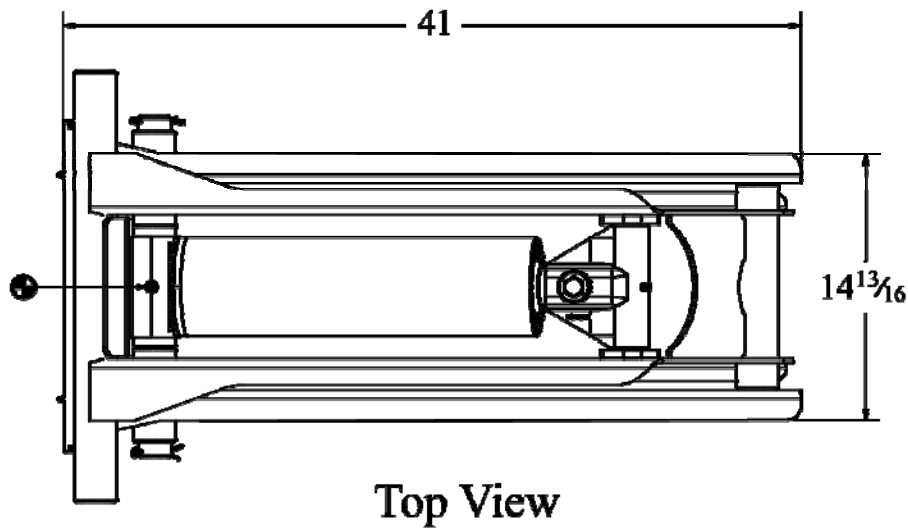

 Grease Fitting Locations

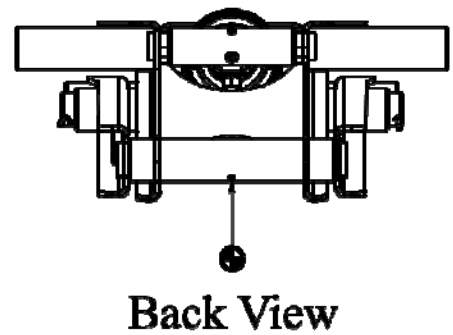
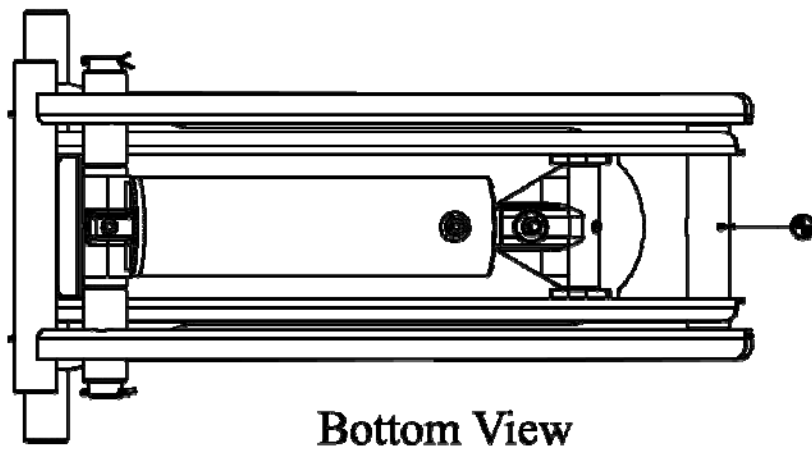

# CS515TRK Parts List

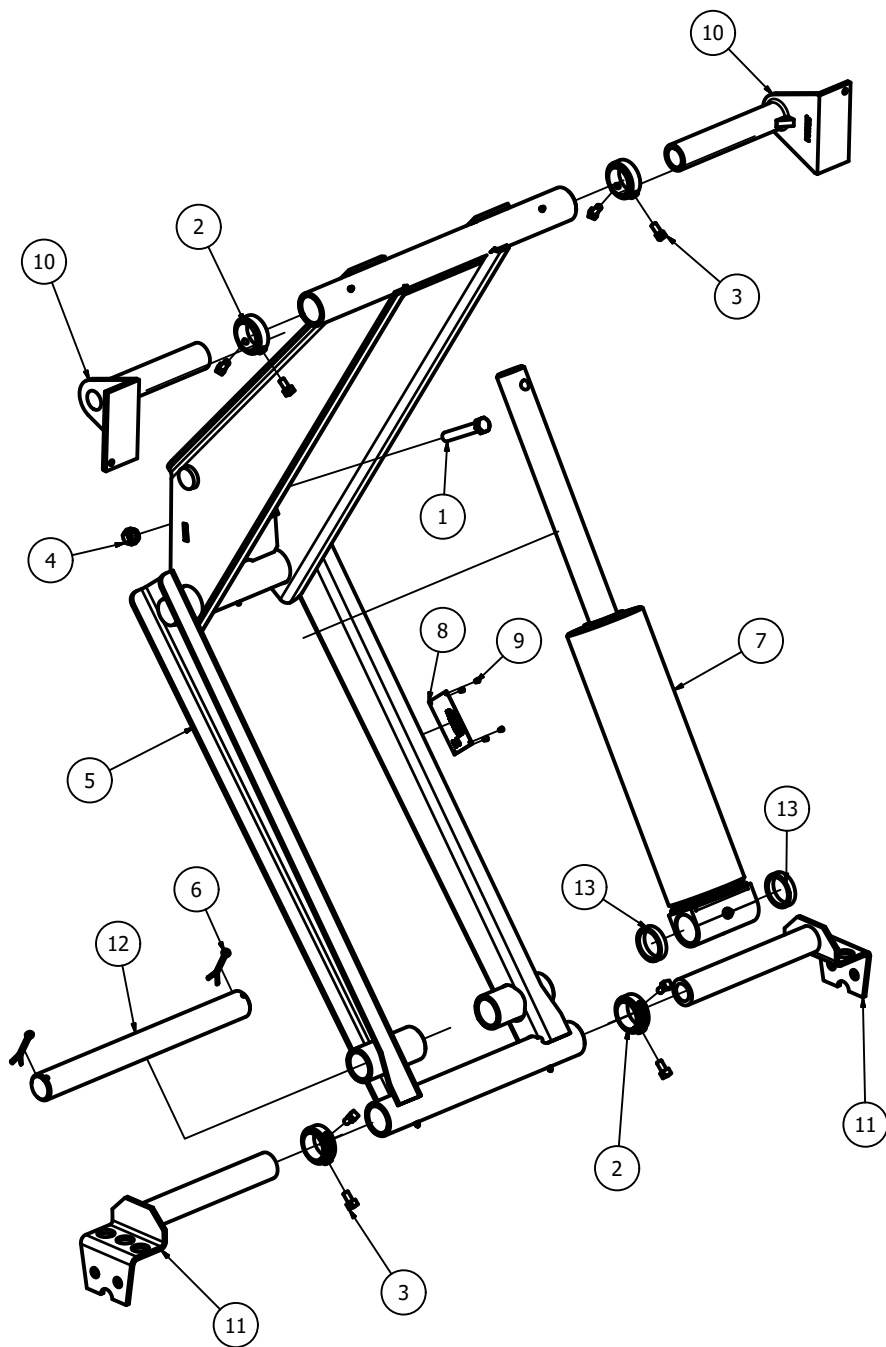

## PARTS LIST

ITEM	QTY	PART NUMBER	DESCRIPTION
1	1	102-617-L	Hex Cap Screw, 5/8 x 4, GR 9
2	4	PC12161	COLLAR, LIFT ARM 1-7/8"
3	8	P34	SET SCREW 3/8"-16 x 3/4" SQHD
4	1	143-7	5/8" NYLON LOCK NUT
5	1	W12334	SCISSOR HOIST WELDMENT, 415T/515T/615T
6	2	125-259	COTTER PIN, 1/4 x 2 1/2
7	1	A21322	ASSEMBLY, 515 DA CYLINDER
8	1	P10200	CHAMPION SERIAL PLATE
9	4	PAAP43	RIVET, 1/8" CHERRY POP
10	2	PC10627	UPPER LIFT ARM, 1-7/8"
11	2	W12352	1 7/8 LOWER LIFT ARM WELDMENT, TRAILER HOIST TRUCK APPLICATION
12	1	PC12651	BOTTOM CYLINDER SHAFT, 415/515/615/615LS415T/515T/615T
13	2	PC12572	2" SPACER

## CS615TRK Capacities

CS615TRK Hoist Capacity (Tons)			
Body Length (Feet)	Overhang (Inches)	Dump Angle (Degrees)	
		"G" Dimension (Inches)	
		45 Deg.(76 Inches)	50 Deg. (69 Inches)
10	0	11.10	10.10
	12	13.90	12.60
	18	15.90	14.40
	24	18.50	16.80
11	0	10.10	9.20
	12	13.90	11.20
	18	13.90	12.60
	24	15.90	14.40
12	0	9.30	8.40
	12	11.10	10.10
	18	12.40	11.20
	24	13.90	12.60
13	0	8.60	7.80
	12	10.10	9.20
	18	11.10	10.10
	24	12.40	11.20

# CS615TRK Dimensions

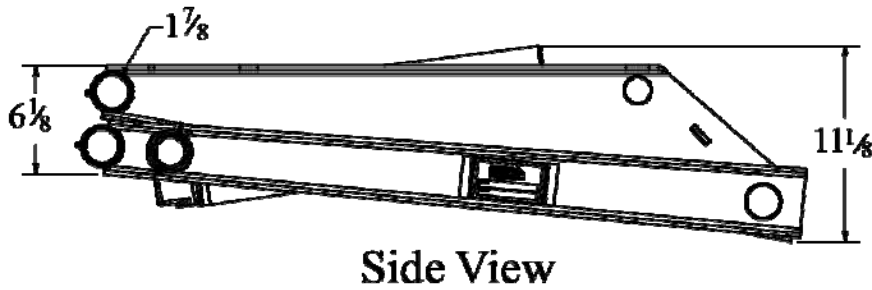
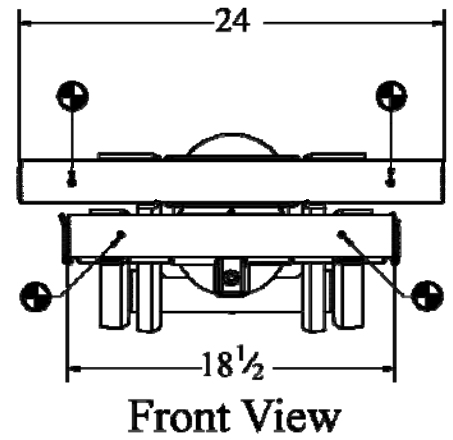
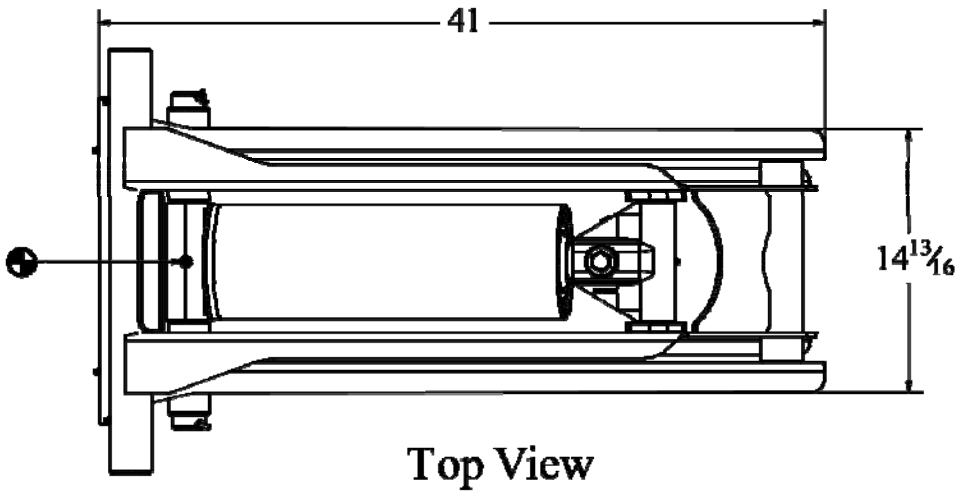

 Grease Fitting Locations

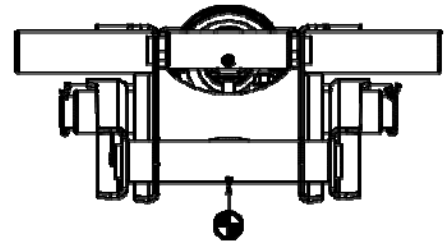
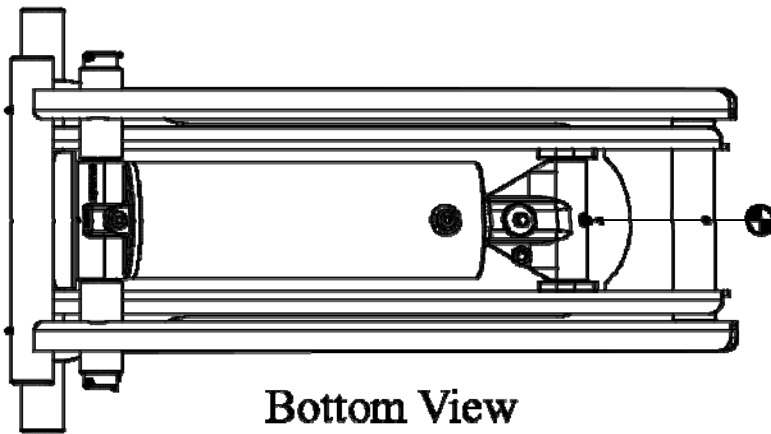



# CS615TRK Parts List

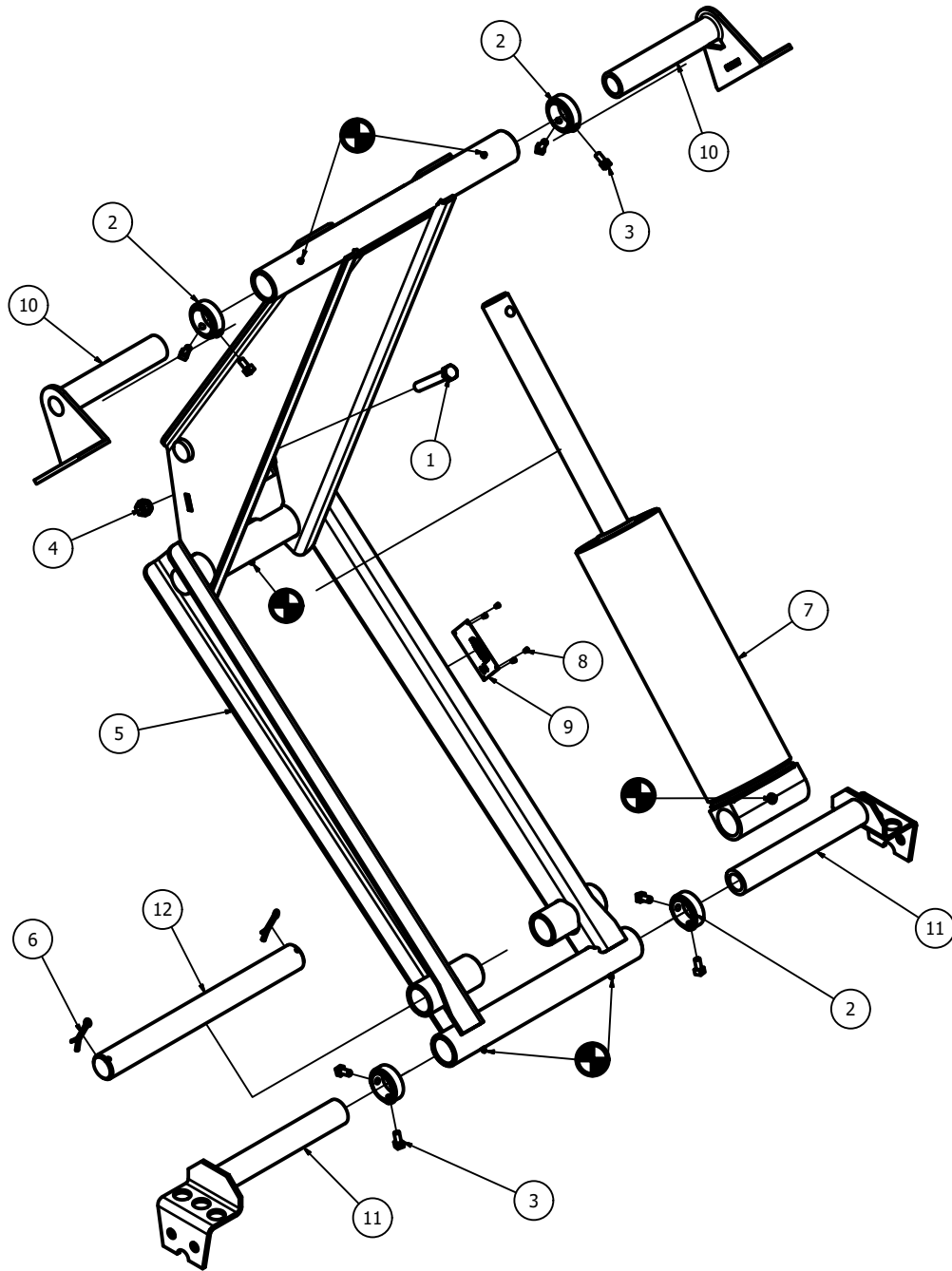

PARTS LIST			
ITEM	QTY	PART NUMBER	DESCRIPTION
1	1	102-617-L	Hex Cap Screw, 5/8 x 4, GR 9
2	4	PC12161	COLLAR, LIFT ARM 1-7/8"
3	8	P34	SET SCREW 3/8"-16 x 3/4" SQHD
4	1	143-7	5/8" NYLON LOCK NUT
5	1	W12334	SCISSOR HOIST WELDMENT, 415T/515T/615T
6	2	125-259	COTTER PIN, 1/4 x 2 1/2
7	1	W21214	WELDMENT, 615 CYLINDER & CAP
8	4	PAAP43	RIVET, 1/8" CHERRY POP
9	1	P10200	CHAMPION SERIAL PLATE
10	2	PC10627	UPPER LIFT ARM, 1-7/8"
11	2	W12352	1 7/8 LOWER LIFT ARM WELDMENT, TRAILER HOIST TRUCK APPLICATION
12	1	PC12651	BOTTOM CYLINDER SHAFT, 415/515/615/615LS415T/515T/615T

# CS412TRK/CS415TRK/CS515TRK/CS615TRK Rear Hinge Assembly

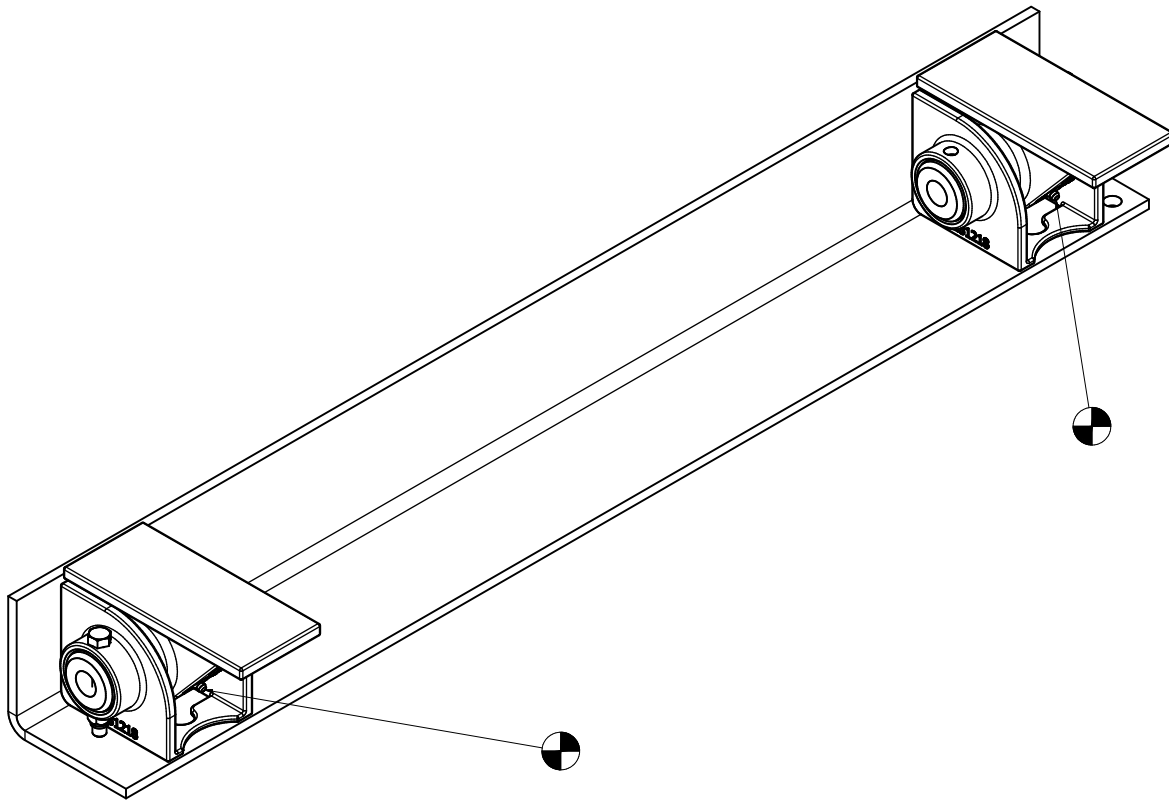

 - Grease Point Location

PARTS LIST			
ITEM	QTY	PART NUMBER	DESCRIPTION
1	2	PC10463	HINGE - 1-3/4" FLIPPER
2	1	F13694	REAR HINGE ANGLE - ALTEC
3	2	PC131218	REAR HINGE SUPPORT, 1-3/4" - 50 DEG. BOLT-IN PIN
4	2	PC10816	1-3/4" REAR HINGE PIN, SHORT VERSION
5	2	102-213-A1	HEX BOLT, 3/8 X 3 LG. GR 8
6	2	P800	1/8" PIPE THREAD GREASE FITTING
7	2	162-8-S	HEX LOCK NUT (STOVER) 3/8

## CS520TRK Capacities

CS520TRK Hoist Capacity (Tons)			
Body Length (Feet)	Overhang (Inches)	Dump Angle (Degrees)	
		"G" Dimension (Inches)	
		45 Deg.(105.5 Inches)	50 Deg. (95.5 Inches)
12	0	8.50	7.70
	12	10.20	9.20
	18	11.30	10.30
	24	12.80	11.60
13	0	7.90	7.10
	12	9.30	8.40
	18	10.20	9.20
	24	11.30	10.30
14	0	7.30	6.60
	12	8.50	7.70
	18	9.30	8.40
	24	10.20	9.20
15	0	6.80	6.20
	12	7.90	7.10
	18	8.50	7.70
	24	9.30	8.40
16	0	6.40	5.80
	12	7.30	6.60
	18	7.90	7.10
	24	8.50	7.70

# CS520TRK Dimensions

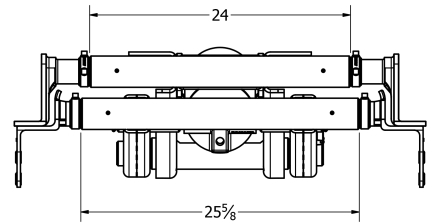
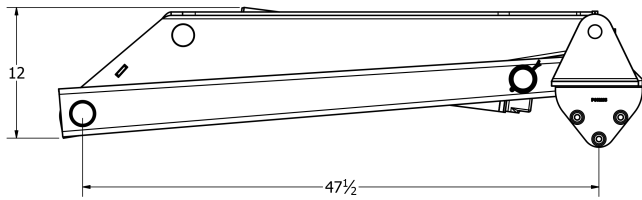
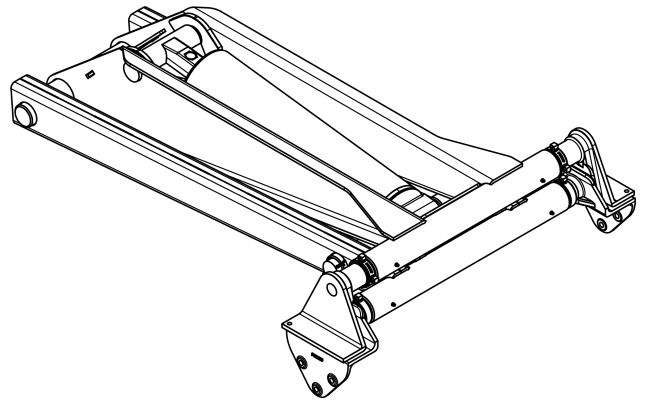
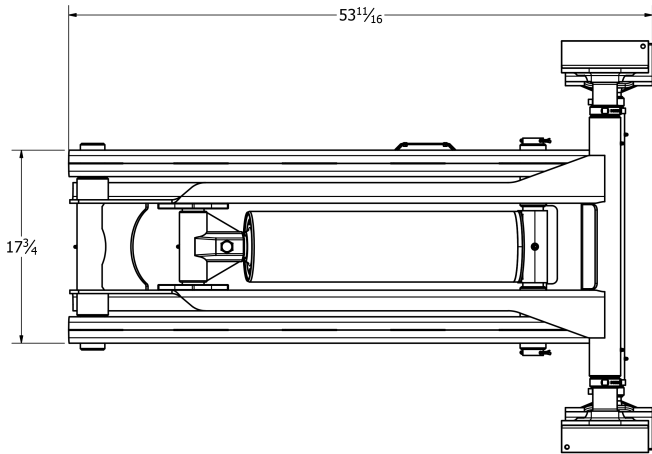

## CS520TRK Parts List

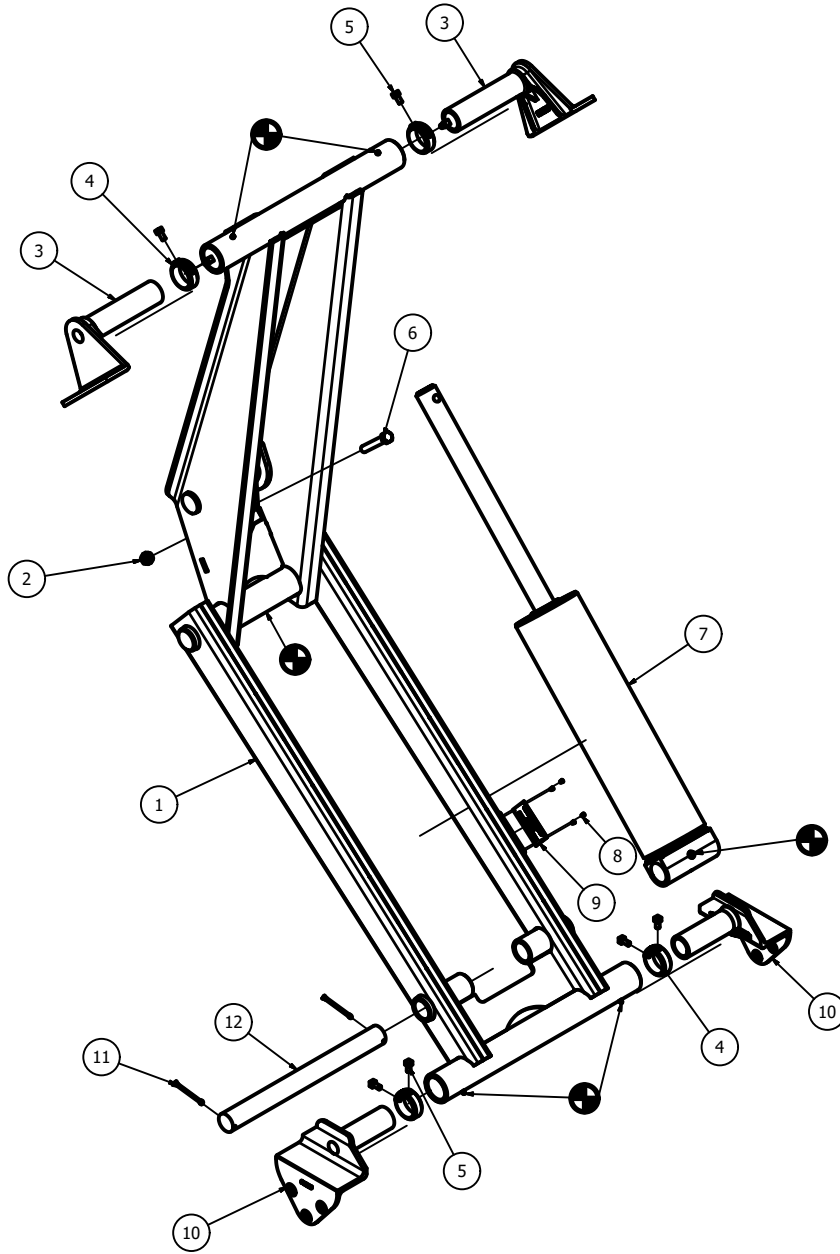

### PARTS LIST

ITEM	QTY	PART NUMBER	DESCRIPTION
1	1	W12335	SCISSOR HOIST WELDMENT, 520T/620T
2	1	143-7	5/8" NYLON LOCK NUT
3	2	PC10626	2-1/4" UPPER LIFT ARM
4	4	PC12157	SET COLLAR FOR 2-1/4" LIFT ARM
5	8	P34	SET SCREW 3/8"-16 x 3/4" SQHD
6	1	102-617-L	Hex Cap Screw, 5/8 x 4, GR 9
7	1	W21215	WELDMENT, 6-20 DA CYLINDER & CAP
8	4	PAAP43	RIVET, 1/8" CHERRY POP
9	1	P10100	SERIAL PLATE
10	2	PC13285	LOWER LIFT ARM, 2 1/4"
11	2	125-257	PIN, COTTER 2"
12	1	PC12600	CYLINDER MOUNT SHAFT, 520T/620T

## CS620TRK Capacities

CS620TRK Hoist Capacity (Tons)			
Body Length (Feet)	Overhang (Inches)	Dump Angle (Degrees)	
		"G" Dimension (Inches)	
		45 Deg.(105.5 Inches)	50 Deg. (95.5 Inches)
12	0	12.30	11.10
	12	14.70	13.30
	18	16.30	14.80
	24	18.40	16.60
13	0	11.30	10.20
	12	13.40	12.10
	18	14.70	13.30
	24	16.30	14.80
14	0	10.50	9.50
	12	12.30	11.10
	18	13.40	12.10
	24	14.70	13.30
15	0	9.80	8.90
	12	11.30	10.20
	18	12.30	11.10
	24	13.40	12.10
16	0	9.20	8.30
	12	10.50	9.50
	18	11.30	10.20
	24	12.30	11.10

# CS620TRK Dimensions

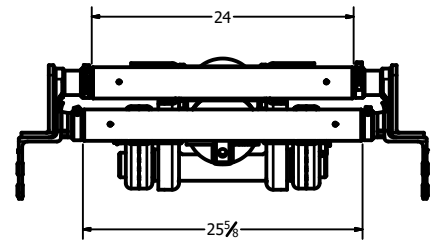
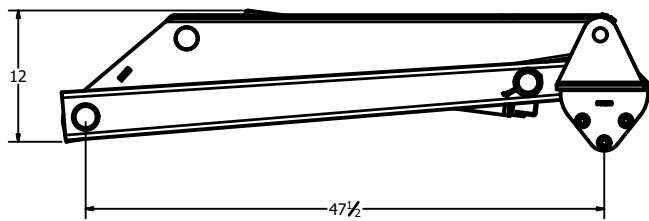
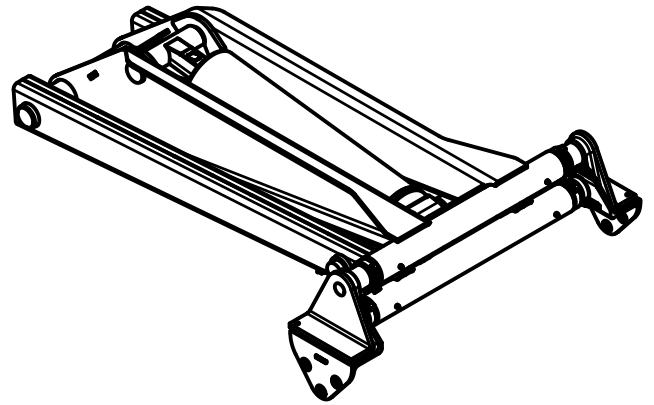
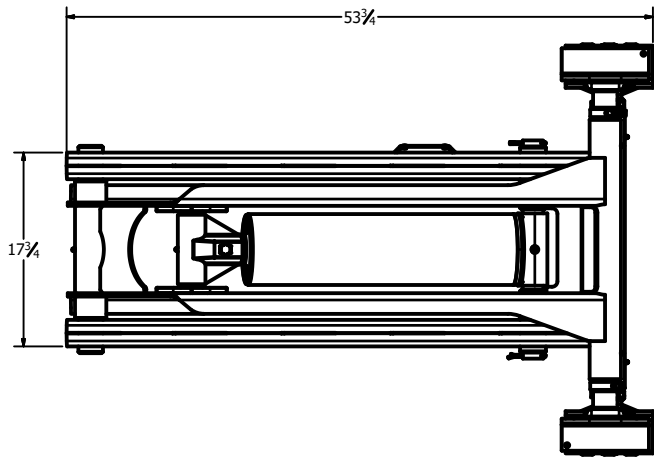

## CS620TRK Parts List

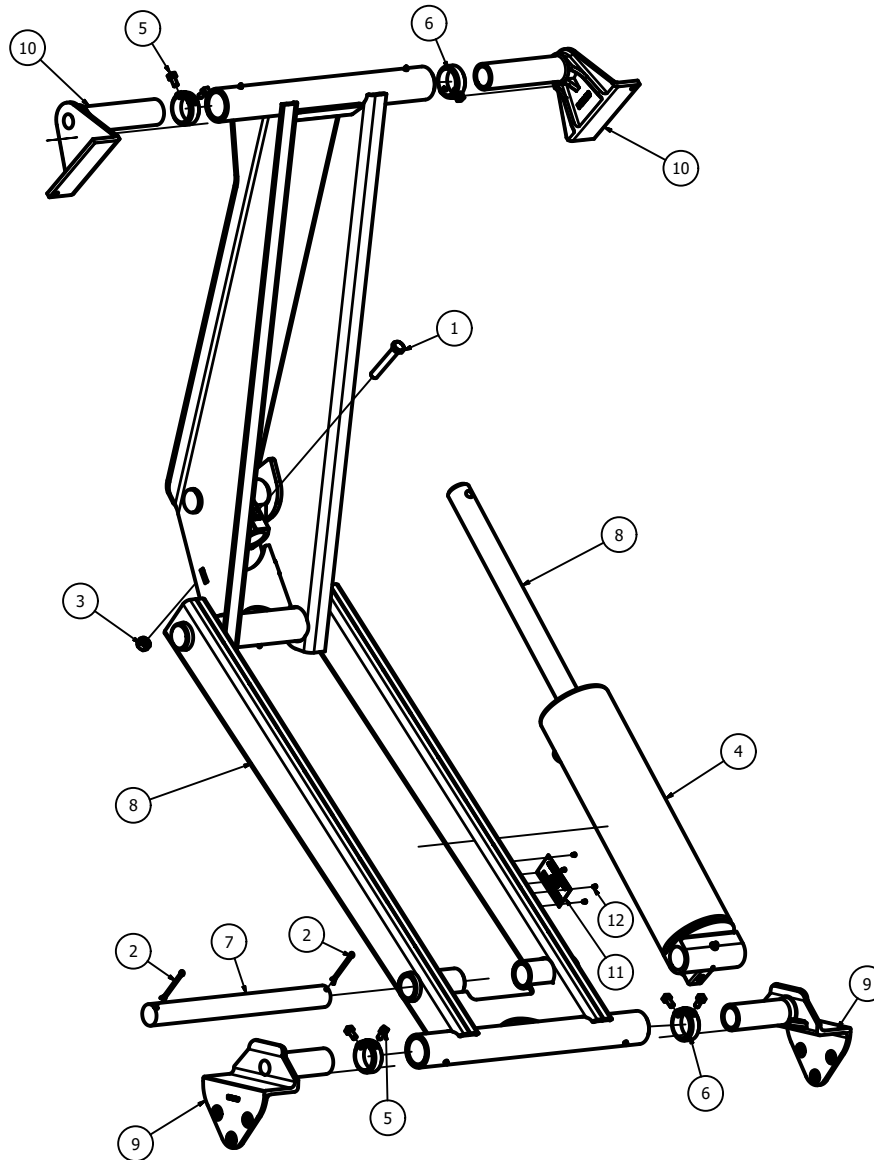

### PARTS LIST

ITEM	QTY	PART NUMBER	DESCRIPTION
1	1	102-617-A1	CAP SCREW, 5/8 x 4
2	2	125-257	PIN, COTTER 2"
3	1	162-10-S	1/2" LOCK NUT
4	1	W21215	WELDMENT, 6-20 DA CYLINDER & CAP
5	8	P34	SET SCREW 3/8"-16 x 3/4" SQHD
6	4	PC12157	SET COLLAR FOR 2-1/4" LIFT ARM
7	1	PC12600	CYLINDER MOUNT SHAFT, 520T/620T
8	1	W12335	SCISSOR HOIST WELDMENT, 520T/620T
9	2	PC13285	LOWER LIFT ARM, 2 1/4"
10	2	PC10626	2-1/4" UPPER LIFT ARM
11	1	P10100	SERIAL PLATE
12	4	PAAP43	RIVET, 1/8" CHERRY POP



## CS5520TRK Capacities

CS5520TRK Hoist Capacity (Tons)			
Body Length (Feet)	Overhang (Inches)	Dump Angle (Degrees)	
		"G" Dimension (Inches)	
		45 Deg.(105.5 Inches)	50 Deg. (95.5 Inches)
14	0	14.60	13.20
	12	17.00	15.40
	18	18.60	16.80
	24	20.40	18.50
15	0	13.60	12.30
	12	15.70	14.20
	18	17.00	15.40
	24	18.60	16.80
16	0	12.80	11.60
	12	14.60	13.20
	18	15.70	14.20
	24	17.00	15.40
17	0	12.00	10.90
	12	13.60	12.30
	18	14.60	13.20
	24	15.70	14.20
18	0	11.30	10.30
	12	12.80	11.60
	18	13.60	12.30
	24	14.60	13.20

# CS5520TRK Dimensions

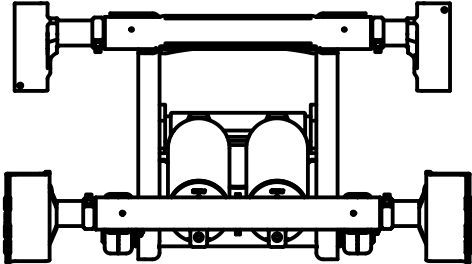
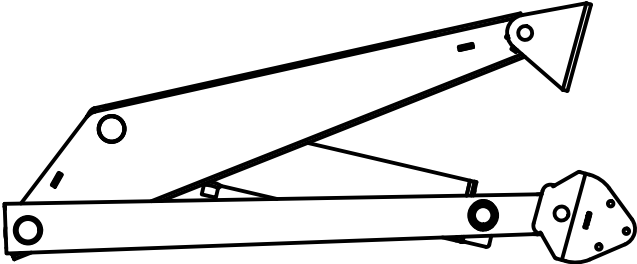
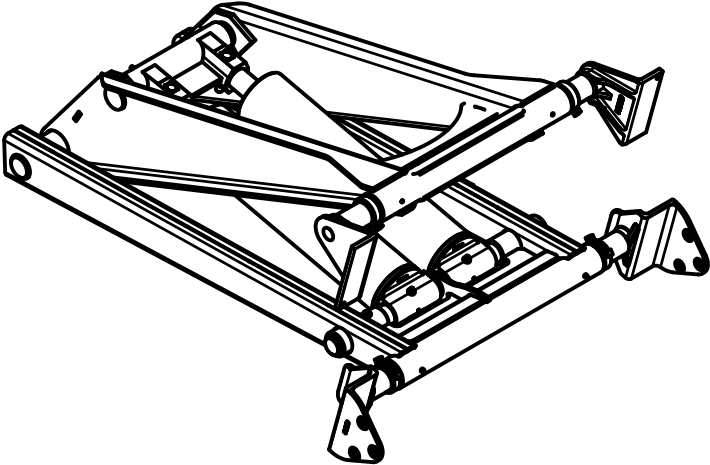
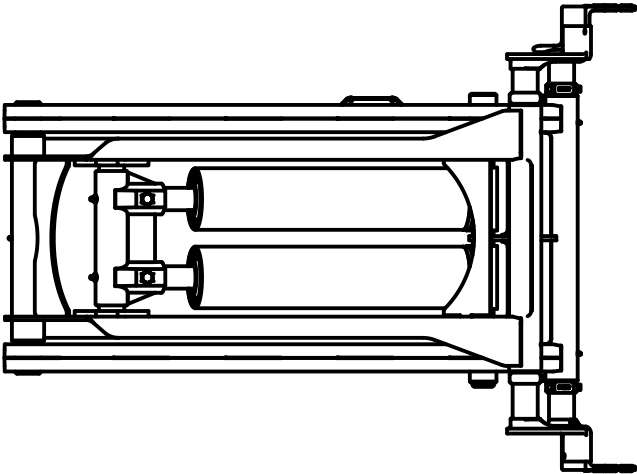

# CS5520TRK Parts List

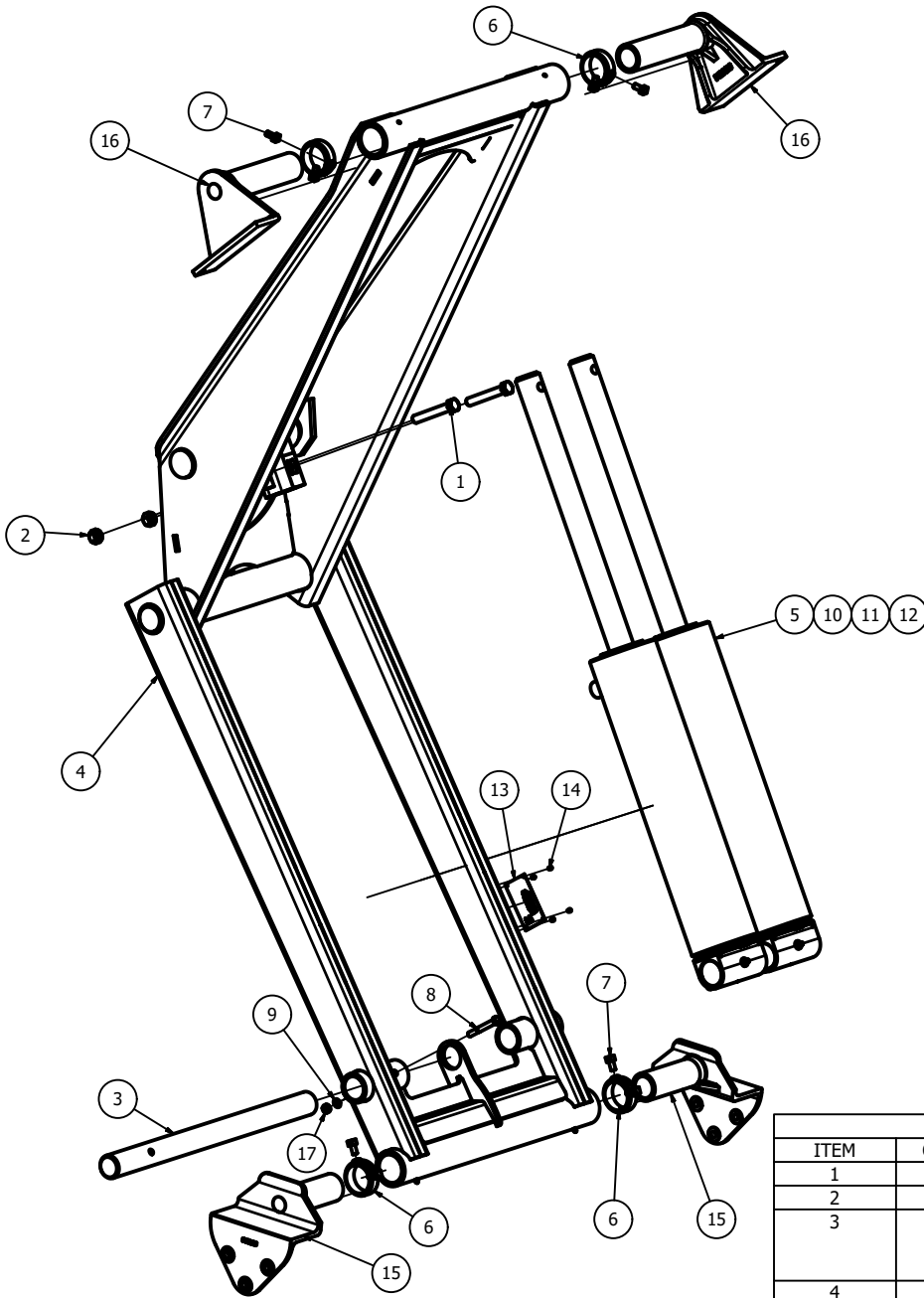

PARTS LIST			
ITEM	QTY	PART NUMBER	DESCRIPTION
1	2	102-617-L	Hex Cap Screw, 5/8 x 4
2	2	162-10-S	1/2" LOCK NUT
3	1	SM12058	CYLINDER MOUNT SHA 6615/6620/5530/6630/5 6620T
4	1	W12336	WELDMENT, 5520T/662 SCISSOR HOIST
5	2	M21015	HYDRAULIC CYLINDER FOR 520/620
6	4	PC12157	SET COLLAR FOR 2-1/4 ARM
7	8	P34	SET SCREW 3/8"-16 x 3 SQHD
8	1	102-213-A1	HEX BOLT, 3/8 X 3 LG.
9	1	118-3-A1	Lock Washer, 3/8
10	2	W21250	WELDMENT, 520 DA CYLINDER
11	2	PC21143	5 INCH GLAND-2-1/2 IN SHAFT
12	2	PC21123	5" PISTON
13	1	P10200	CHAMPION SERIAL PLA
14	4	PAAP43	RIVET, 1/8" CHERRY PO
15	2	PC13285	LOWER LIFT ARM, 2 1/
16	2	PC10626	2-1/4" UPPER LIFT ARM
17	1	ANSI B18.2.2 - 3/8 - 16	Hex Nuts (Inch Series)

## CS6620TRK Capacities

CS6620TRK Hoist Capacity (Tons)			
Body Length (Feet)	Overhang (Inches)	Dump Angle (Degrees)	
		"G" Dimension (Inches)	
		45 Deg.(105.5 Inches)	50 Deg. (95.5 Inches)
14	0	21.00	19.00
	12	24.50	22.20
	18	26.70	24.20
	24	29.40	26.60
15	0	19.60	17.70
	12	22.60	20.50
	18	24.50	22.20
	24	26.70	24.20
16	0	18.40	16.60
	12	21.00	19.00
	18	22.60	20.50
	24	24.50	22.20
17	0	17.30	15.70
	12	19.60	17.70
	18	21.00	19.00
	24	22.60	20.50
18	0	16.30	14.80
	12	18.40	16.60
	18	19.60	17.70
	24	21.00	19.00

# CS6620TRK Dimensions

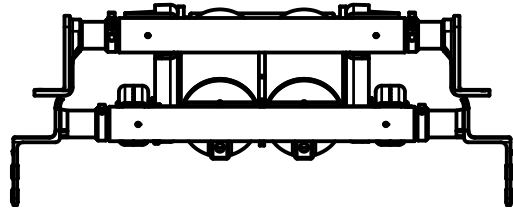
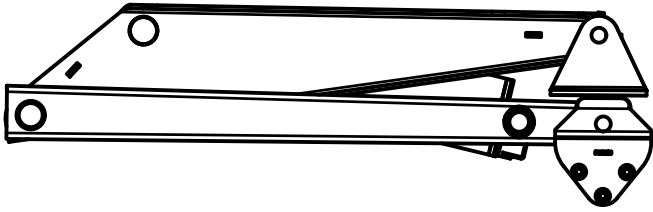
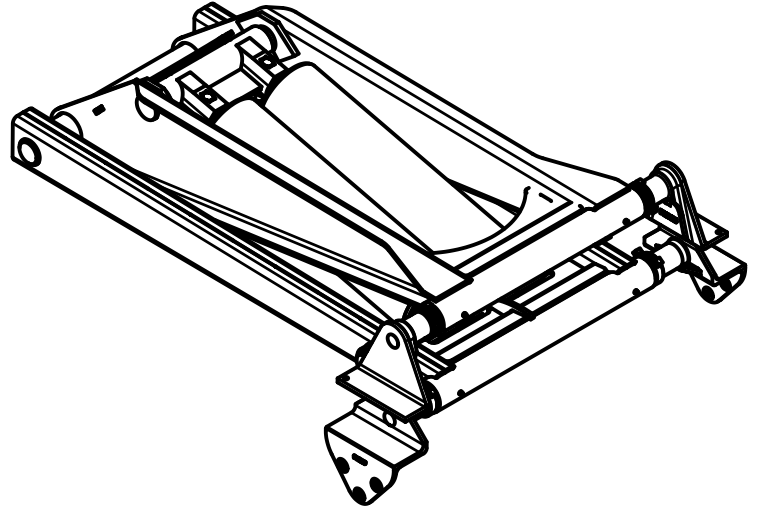
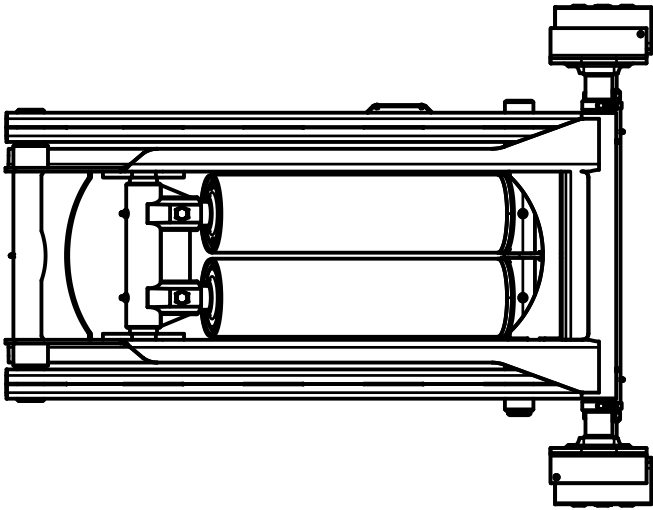

## CS6620TRK Parts List

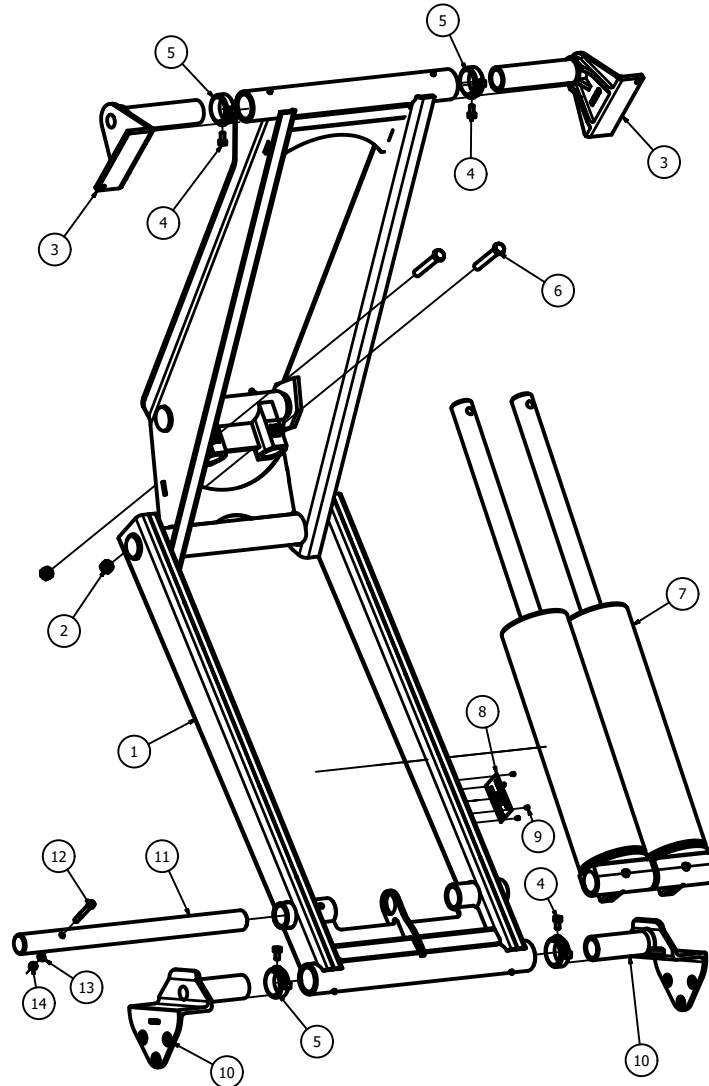

PARTS LIST			
ITEM	QTY	PART NUMBER	DESCRIPTION
1	1	W12336	WELDMNT, 5520T/6620T SCISSOR HOIST
2	2	162-10-S	1/2" LOCK NUT
3	2	PC10626	2-1/4" UPPER LIFT ARM
4	8	P34	SET SCREW 3/8"-16 x 3/4" SQHD
5	4	PC12157	SET COLLAR FOR 2-1/4" LIFT ARM
6	2	102-617-L	Hex Cap Screw, 5/8 x 4, GR 9
7	2	A21328	CYLINDER ASSEMBLY, 6620T DA
8	1	P10100	SERIAL PLATE
9	4	PAAP43	RIVET, 1/8" CHERRY POP
10	2	PC13285	LOWER LIFT ARM, 2 1/4"
11	1	SM12058	CYLINDER MOUNT SHAFT, 6615/6620/5530/6630/5520T/6620T
12	1	102-213-A1	HEX BOLT, 3/8 X 3 LG. GR 8
13	1	118-3-A1	Lock Washer, 3/8
14	1	116-3-A1	Hex Nut, 3/8 UNC

## CS415LP Capacities

CS415LP Hoist Capacity (Tons)			
Body Length (Feet)	Overhang (Inches)	Dump Angle (Degrees)	
		"G" Dimension (Inches)	
		45 Deg.(76 Inches)	50 Deg. (68.5 Inches)
8	0	5.40	4.90
	12	7.20	6.50
	18	8.70	7.80
	24		9.80
9	0	4.80	4.30
	12	6.20	5.60
	18	7.20	6.50
	24	8.70	7.80
10	0	4.30	3.90
	12	5.40	4.90
	18	6.20	5.60
	24	7.20	6.50

# CS415LP Dimensions

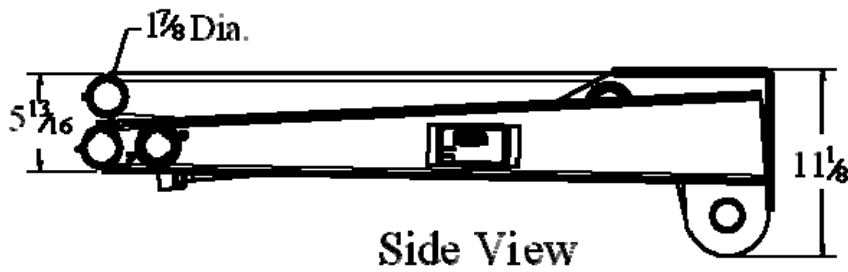
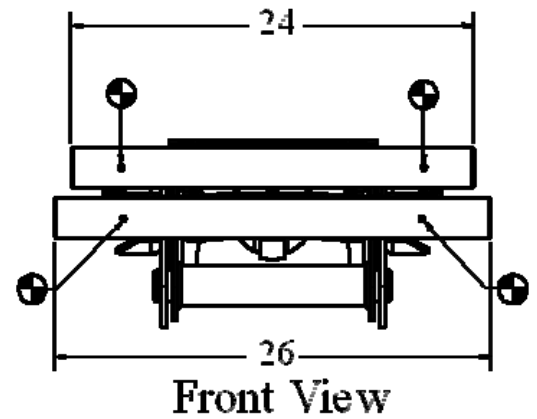
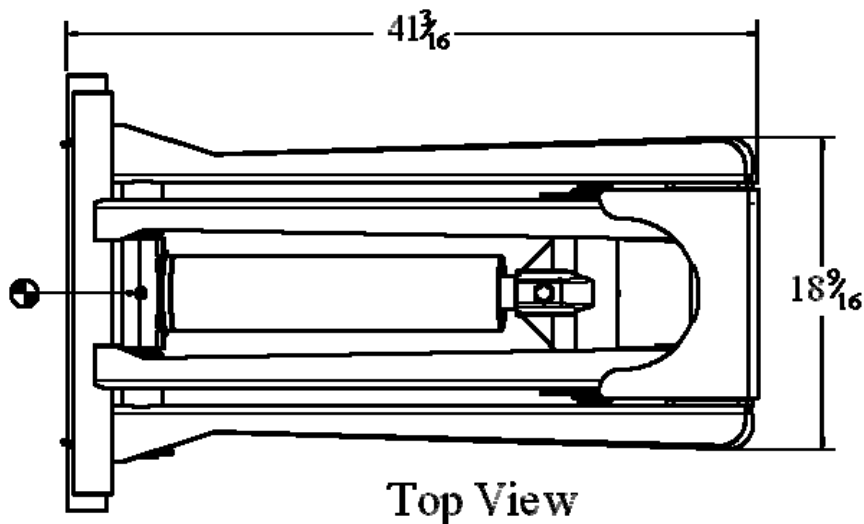

 Grease Fitting Locations

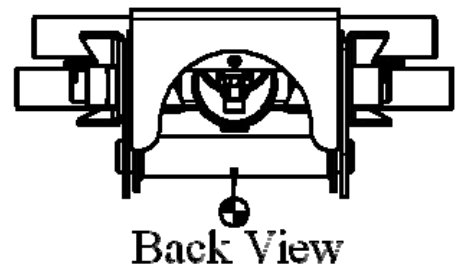
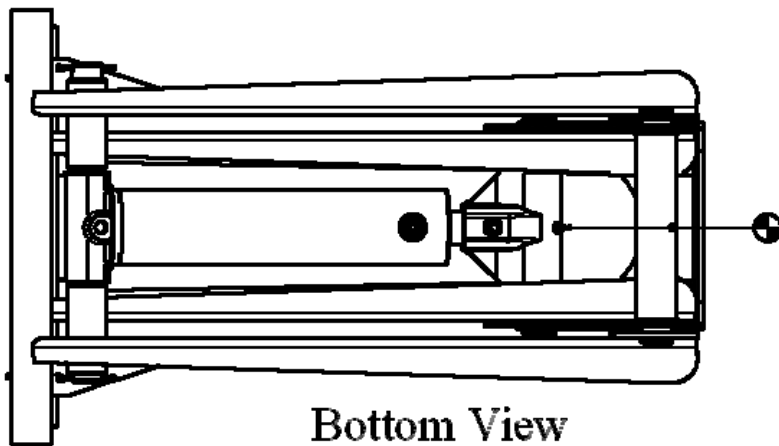



# CS415LP Parts List

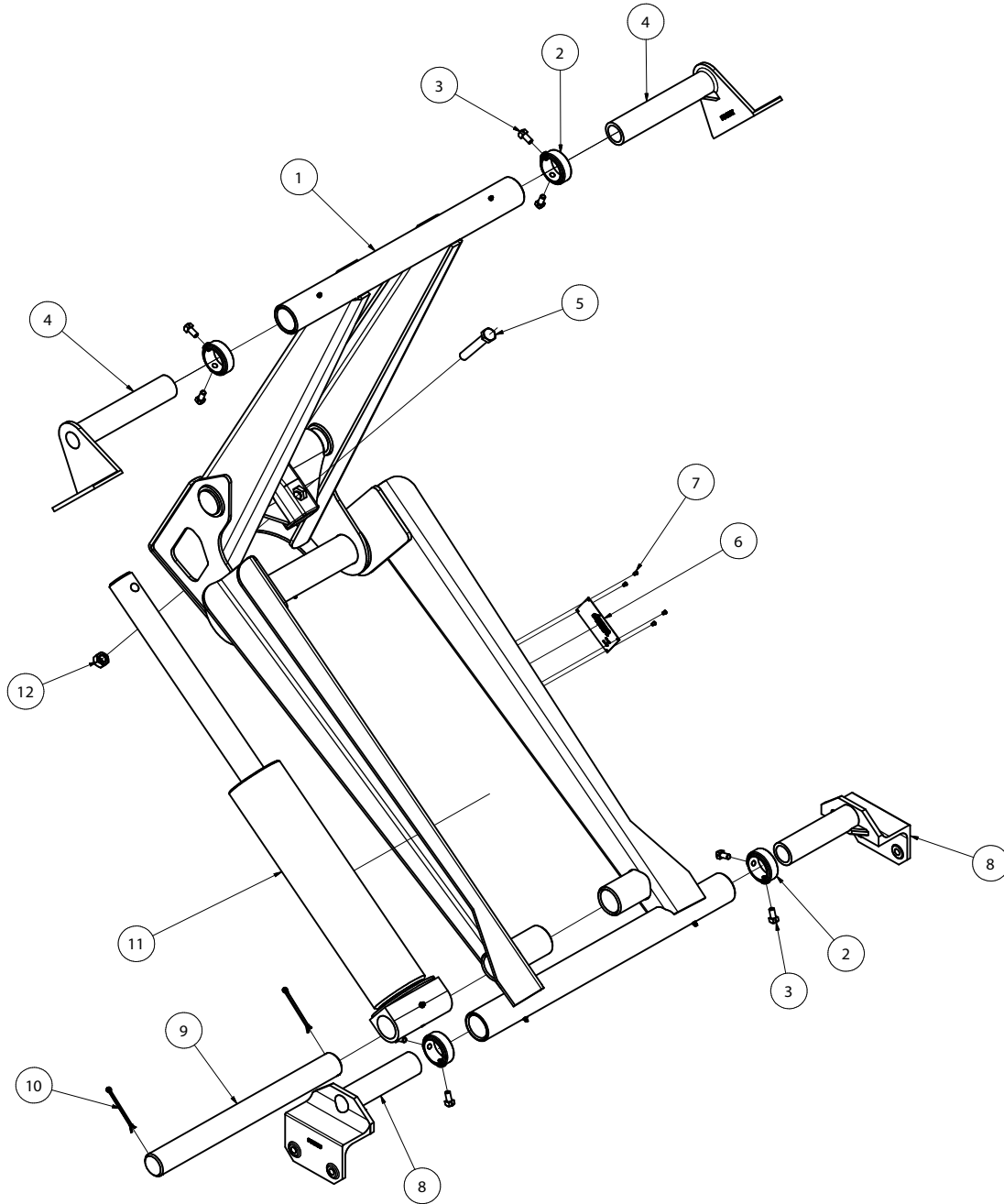

PARTS LIST			
ITEM	QTY	PART NUMBER	DESCRIPTION
1	1	W12403	WELDMENT, 415/515/615 SCISSOR HOIST (FAB CROSS TUBES)
2	4	PC12161	COLLAR, LIFT ARM 1-7/8"
3	8	P34	SET SCREW 3/8"-16 x 3/4" SQHD
4	2	PC10627	UPPER LIFT ARM, 1-7/8"
5	1	102-617-L	Hex Cap Screw, 5/8 x 4, GR 9
6	1	P10200	CHAMPION SERIAL PLATE
7	4	PAAP43	RIVET, 1/8" CHERRY POP
8	2	PC13286	LOWER LIFT ARM, 1-7/8"
9	1	PC12651	BOTTOM CYLINDER SHAFT, 415/515/615/615LS415T/515T/615T
10	2	125-257	PIN, COTTER 2"
11	1	A21321	ASSEMBLY, 415DA CYLINDER
12	1	143-7	5/8" NYLON LOCK NUT

## CS515LP Capacities

CS515LP Hoist Capacity (Tons)			
Body Length (Feet)	Overhang (Inches)	Dump Angle (Degrees)	
		"G" Dimension (Inches)	
		45 Deg.(76 Inches)	50 Deg. (68.5 Inches)
9	0	7.50	6.80
	12	9.70	8.70
	18	11.30	10.20
	24	13.50	12.20
10	0	6.80	6.10
	12	8.50	7.60
	18	9.70	8.70
	24	11.30	10.20
11	0	6.10	5.50
	12	7.50	6.80
	18	8.50	7.60
	24	9.70	8.70

# CS515LP Dimensions

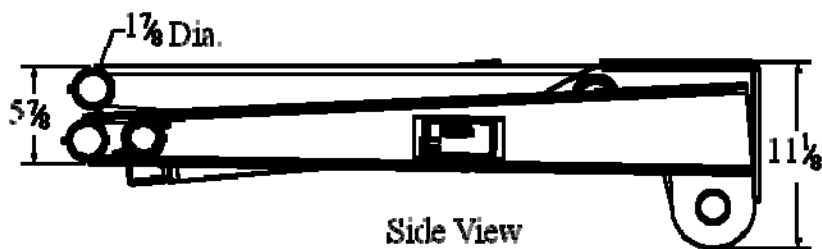
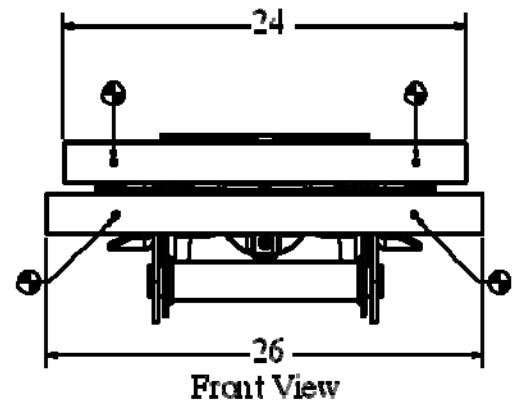
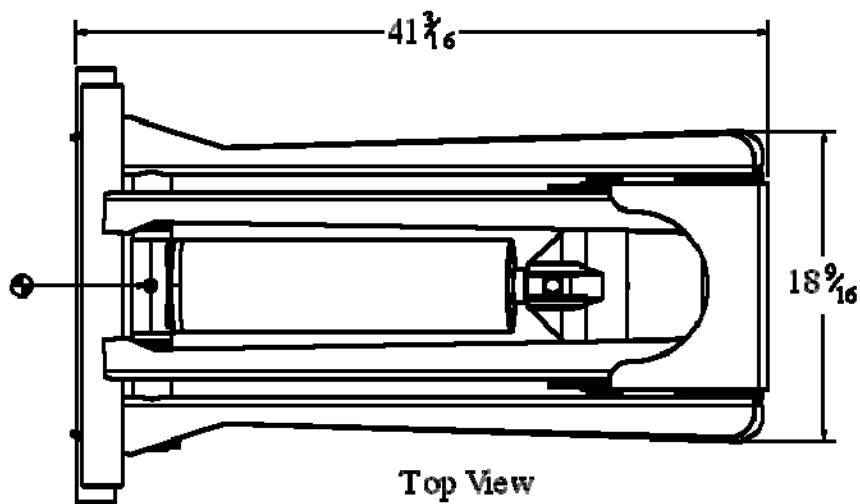

 Grease Fitting Locations

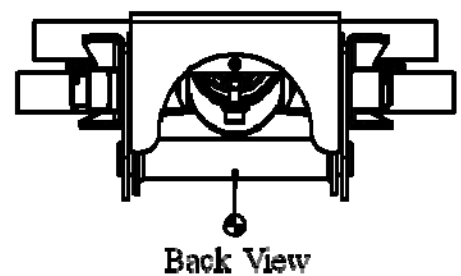
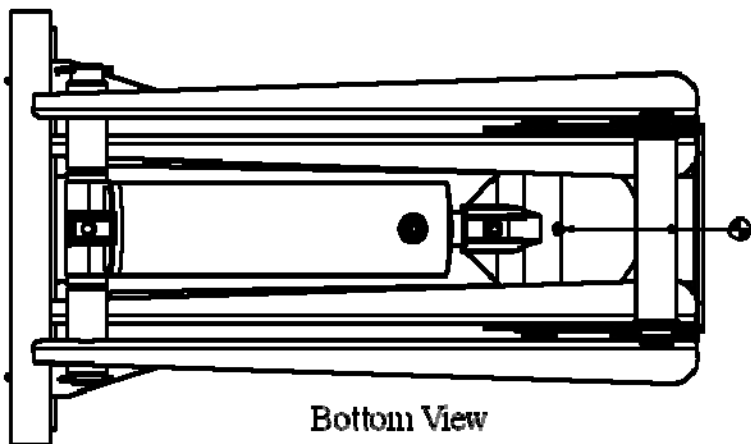

# CS515LP Parts List

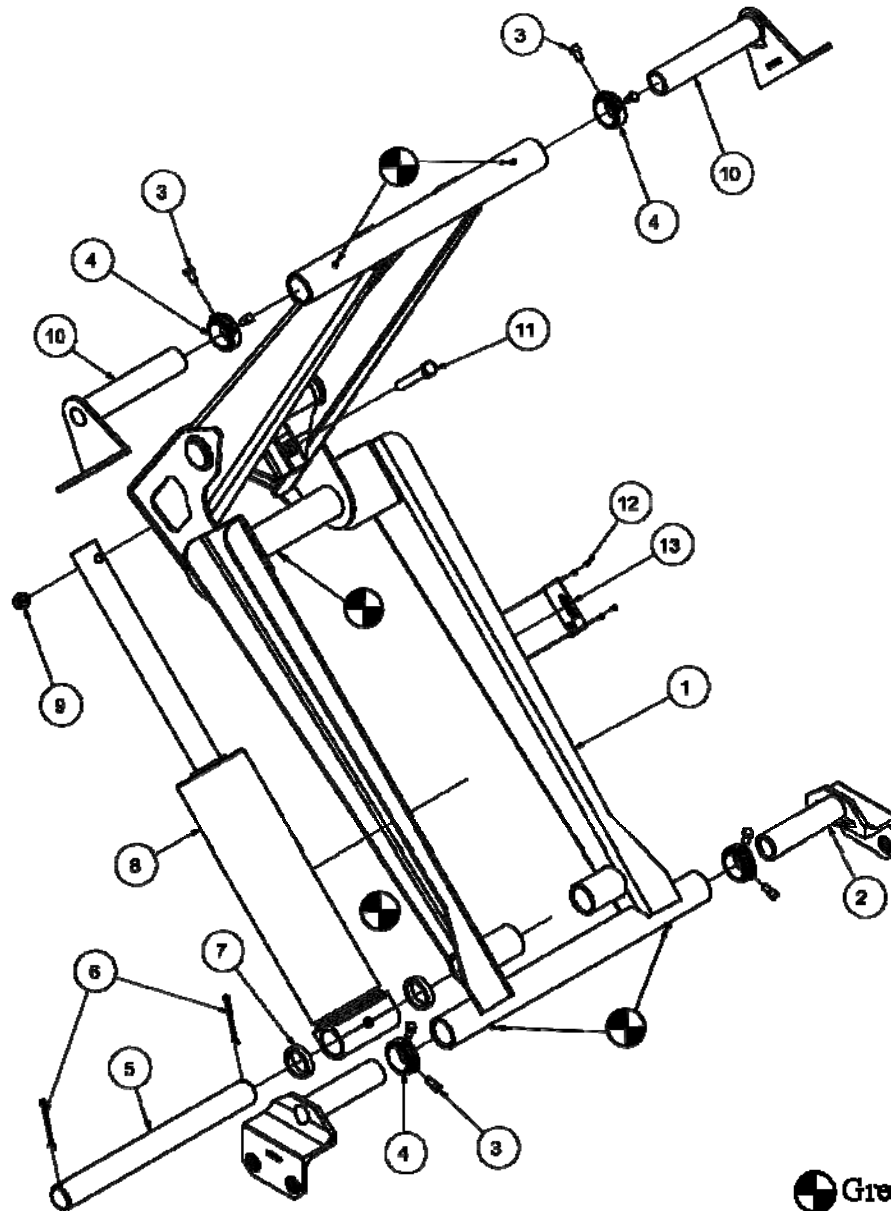

 Grease Fitting Locations

CS515LP - Parts List (refer to engineering drawing A12428)

Item	Qty.	Part Number	Description
1	1	W12403	Weldment, 515 Scissor Hoist (Fab Cross Tubes)
2	2	PC13286	Lower Lift Arm, 1-7/8"
3	8	P34	Set Screw 3/8"-16 x 3/4" Square Head
4	4	PC12161	Collar, Lift Arm 1-7/8"
5	1	PC12651	Bottom Cylinder Shaft, 515/515T
6	2	125-257	Pin, Cotter 2"
7	2	PC12572	2" Spacer
8	1	A21322	515DA Cylinder Assembly
9	1	143-7	Nut, Lock, 5/8 UNC
10	2	PC10627	Upper lift Arm, 1-7/8"
11	1	102-617-L	Hex Cap Screw, 5/8 x 4, GR9
12	4	PAAP43	Rivet, 1/8" Cherry Pop
13	1	P10100	Serial Plate

## CS615LP Capacities

<b>CS615LP Hoist Capacity (Tons)</b>			
<b>Body Length (Feet)</b>	<b>Overhang (Inches)</b>	<b>Dump Angle (Degrees)</b>	
		<b>"G" Dimension (Inches)</b>	
		<b>45 Deg.(76 Inches)</b>	<b>50 Deg. (68.5 Inches)</b>
10	0	9.70	8.80
	12	12.20	11.00
	18	13.90	12.50
	24	16.20	14.60
11	0	8.90	8.00
	12	10.80	9.80
	18	12.20	11.00
	24	13.90	12.50
12	0	8.10	7.30
	12	9.70	8.80
	18	10.80	9.80
	24	12.20	11.00
13	0	7.50	6.80
	12	8.90	8.00
	18	9.70	8.80
	24	10.80	9.80

# CS615LP Dimensions

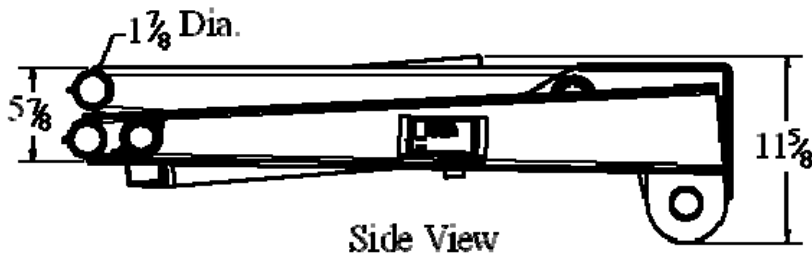
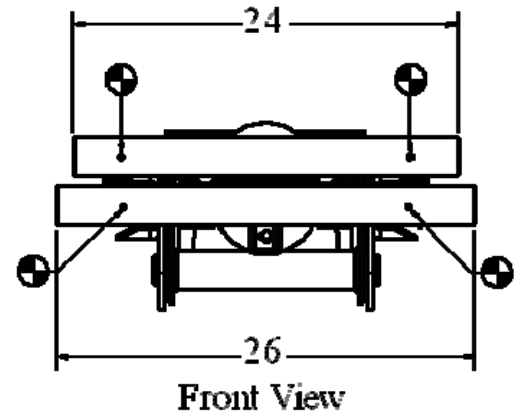
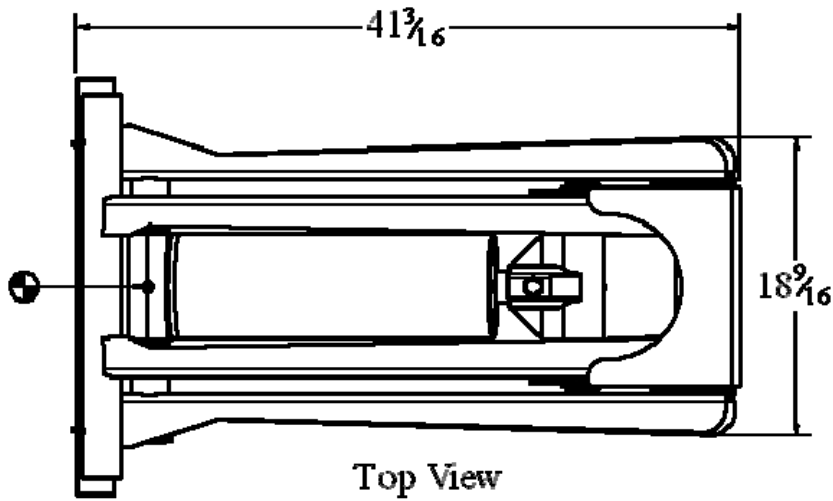

 Grease Fitting Locations

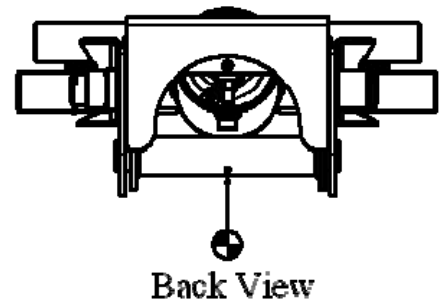
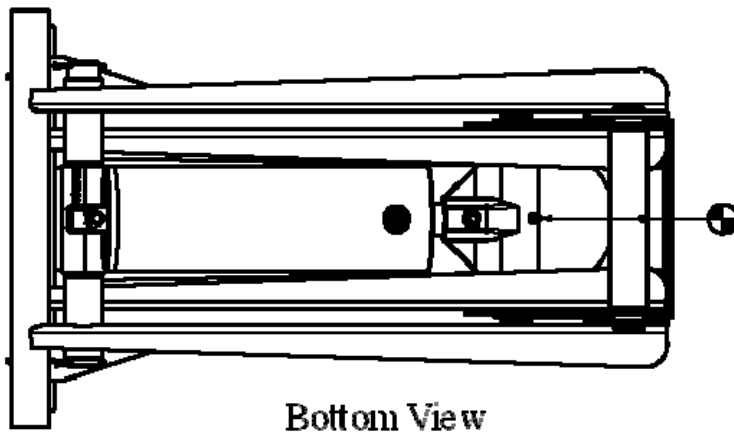

# CS615LP Parts List

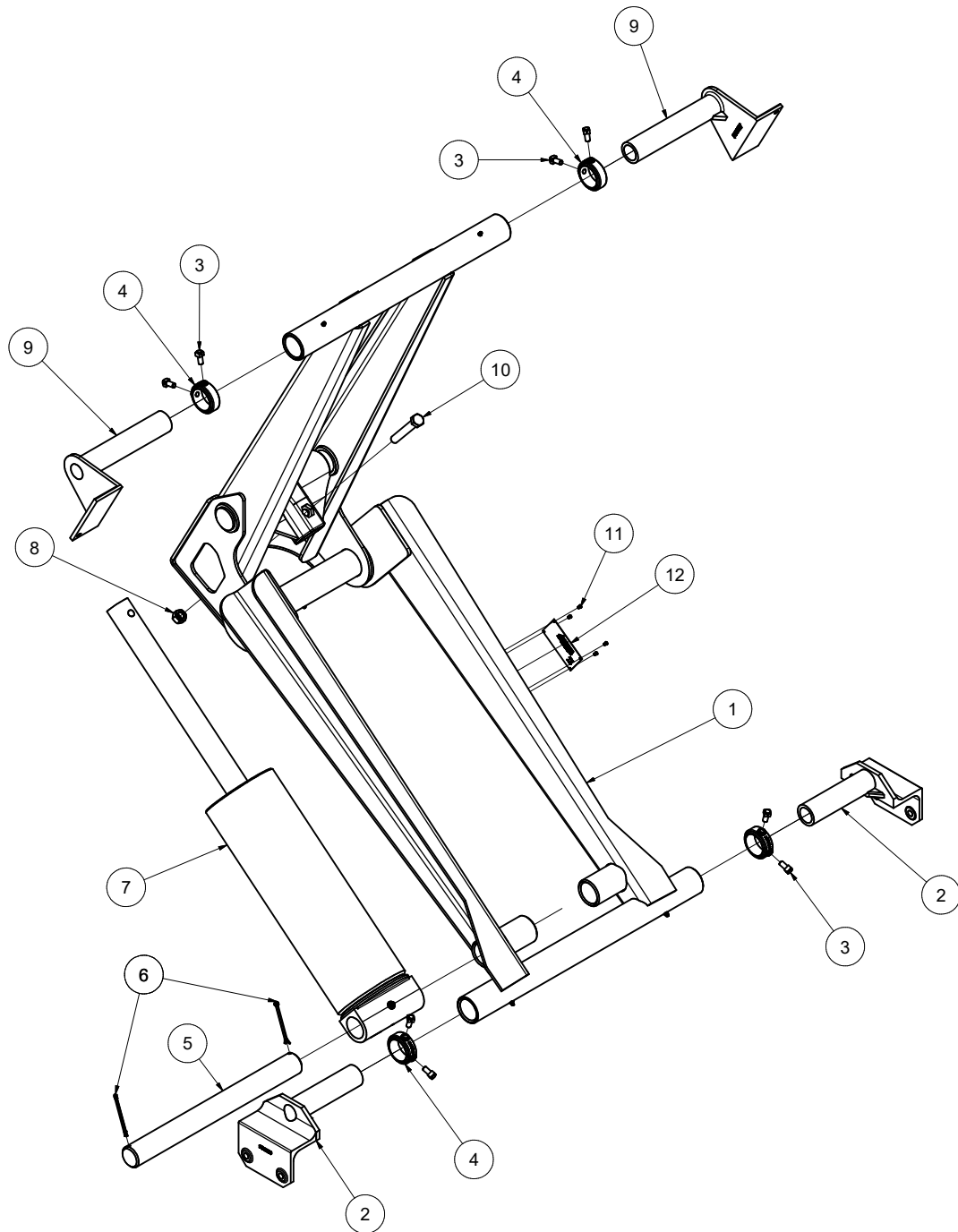

PARTS LIST			
ITEM	QTY	PART NUMBER	DESCRIPTION
1	1	W12403	WELDMENT, GS415/515/615 SCISSOR HOIST
2	2	PC13286	LOWER LIFT ARM, 1-7/8"
3	8	P34	SET SCREW 3/8"-16 x 3/4" SQHD
4	4	PC12161	COLLAR, LIFT ARM 1-7/8"
5	1	PC12651	BOTTOM CYLINDER SHAFT, 415/515/615/615LS415T/515T/615T
6	2	125-257	PIN, COTTER 2"
7	1	A21325	ASSEMBLY, 615DA CYLINDER
8	1	143-7	5/8" NYLON LOCK NUT
9	2	PC10627	UPPER LIFT ARM, 1-7/8"
10	1	102-617-L	Hex Cap Screw, 5/8 x 4, GR 9
11	4	PAAP43	RIVET, 1/8" CHERRY POP
12	1	P10200	CHAMPION SERIAL PLATE

## CS615HDLP Capacities

CS615HDLP Hoist Capacity (Tons)			
Body Length (Feet)	Overhang (Inches)	Dump Angle (Degrees) "G" Dimension (Inches)	
		45 Deg.(82 Inches)	50 Deg. (74 Inches)
10	0	9.30	8.40
	12	11.60	10.50
	18	13.30	12.00
	24	15.50	14.00
11	0	8.40	7.60
	12	10.30	9.30
	18	11.60	10.50
	24	13.30	12.00
12	0	7.70	7.00
	12	9.30	8.40
	18	10.30	10.50
	24	11.60	9.30
13	0	7.10	6.40
	12	8.40	7.60
	18	9.30	8.40
	24	10.30	9.30
14	0	6.60	6.00
	12	6.60	7.00
	18	8.40	7.60
	24	9.30	8.40



# CS615HDLP Dimensions

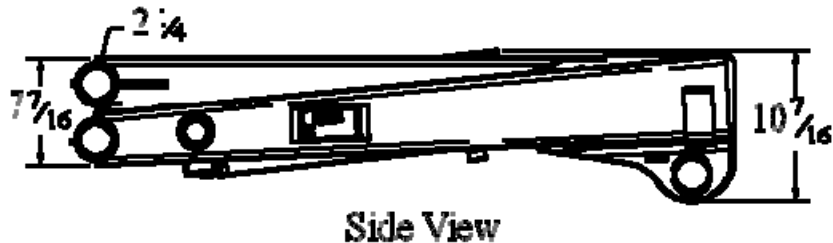
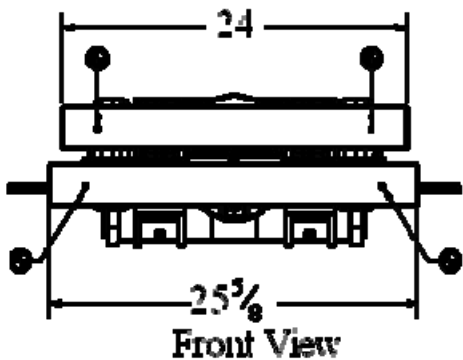
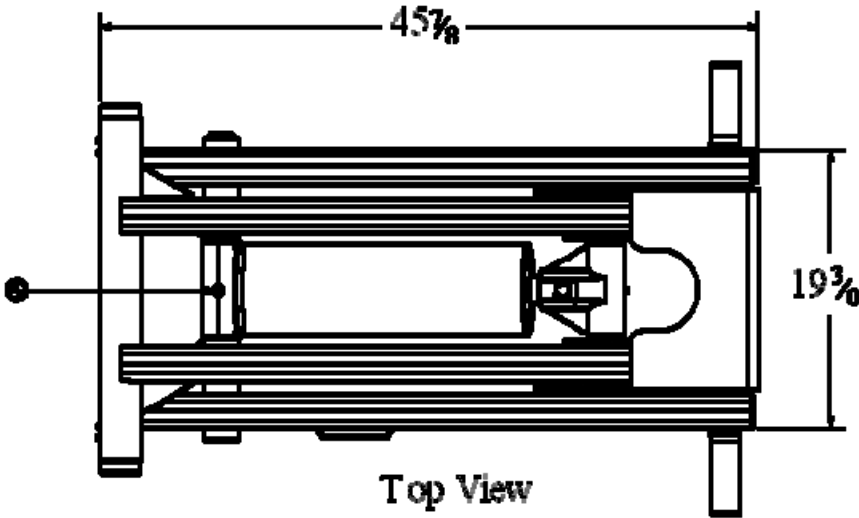

 Grease Fitting Locations

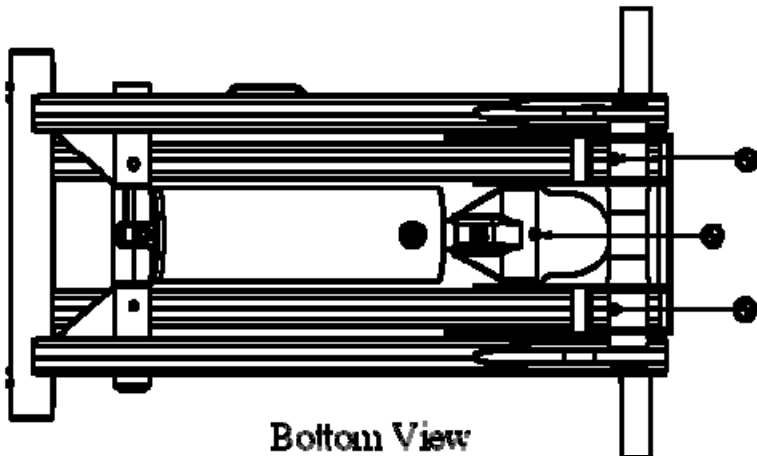

# CS615HDLP Parts List

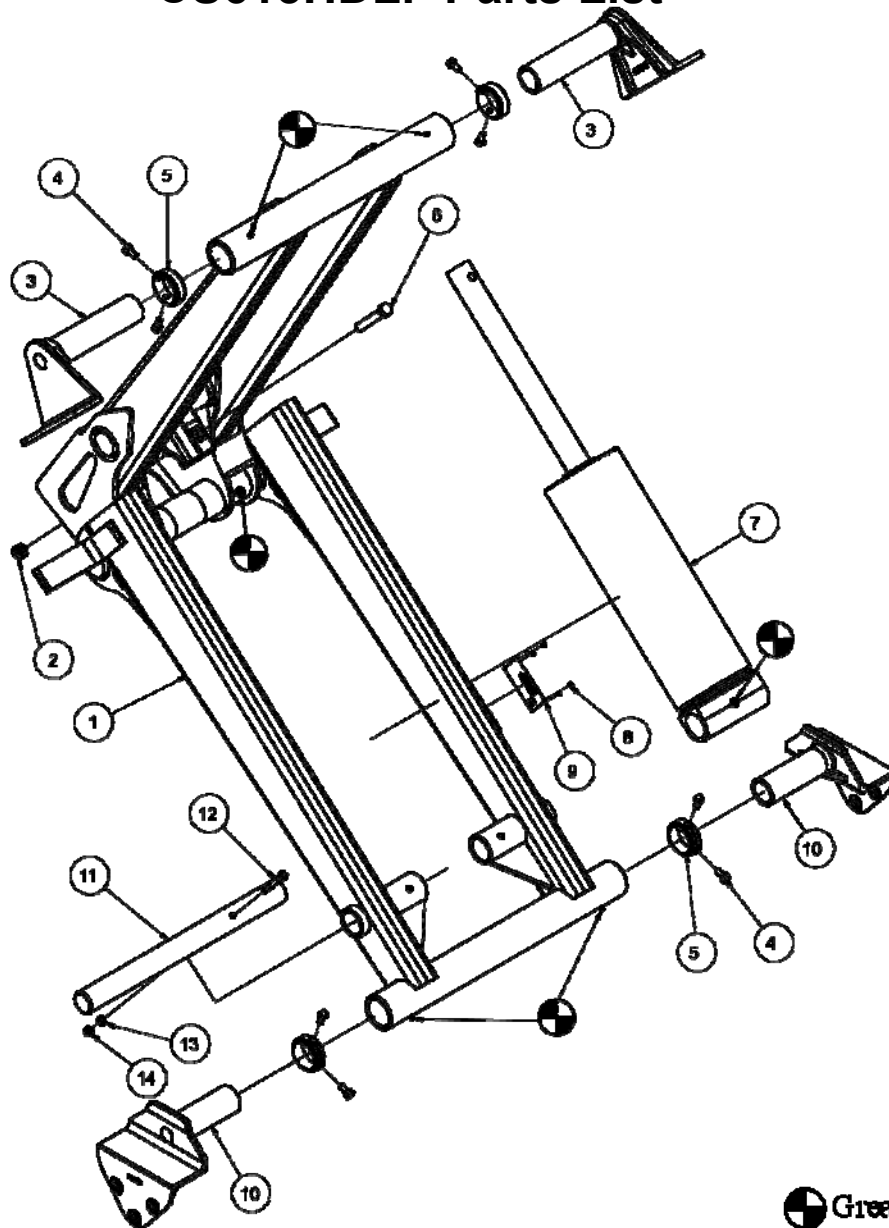

 Grease Fitting Locations

**GS615HDLP - Parts List (refer to engineering drawing A12557)**

Item	Qty.	Part Number	Description
1	1	W12482	615HD Scissor Hoist Weldment (Fab Cross Tubes)
2	1	116-7-A1	Hex Nut, 5/8" UNC
3	2	PC10626	Upper lift Arm, 2-1/4"
4	8	P34	Set Screw 3/8"-16 x 3/4" Square Head
5	4	PC12157	Set Collar for 2-1/4" Lift Arm
6	1	102-617-L	Hex Cap Screw, 5/8" x 4", GR9
7	1	A21323	615 DA Cylinder Assembly
8	4	PAAP43	Rivet, 1/8" Cherry Pop
9	1	P10200	Serial Plate, Champion
10	2	PC13285	Lower Lift Arm, 2-1/4"
11	1	SM12048	Bottom Cylinder Shaft, 615
12	1	102-213-A1	Hex Bolt, 3/8" x 3" LG. GR8
13	1	118-3-A1	Lock Washer, 3/8"
14	1	116-3-A1	Hex Nut, 3/8" UNC

## CS620HDLP Capacities

CS620HDLP Hoist Capacity (Tons)			
Body Length (Feet)	Overhang (Inches)	Dump Angle (Degrees)	
		"G" Dimension (Inches)	
		45 Deg.(105.5 Inches)	50 Deg. (95.5 Inches)
12	0	10.50	9.50
	12	12.60	11.40
	18	14.00	12.70
	24	15.80	14.30
13	0	9.70	8.80
	12	11.50	10.40
	18	12.60	11.40
	24	14.00	12.70
14	0	9.00	8.20
	12	10.50	9.50
	18	11.50	10.40
	24	12.60	11.40
15	0	8.40	7.60
	12	9.70	8.80
	18	10.50	9.50
	24	11.50	10.40
16	0	7.90	7.10
	12	9.00	8.20
	18	9.70	8.80
	24	10.50	9.50

# CS620HDLP Dimensions

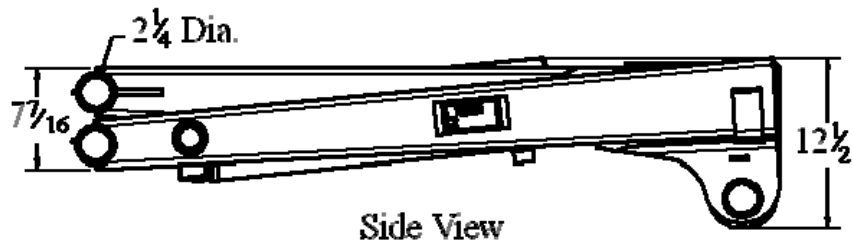
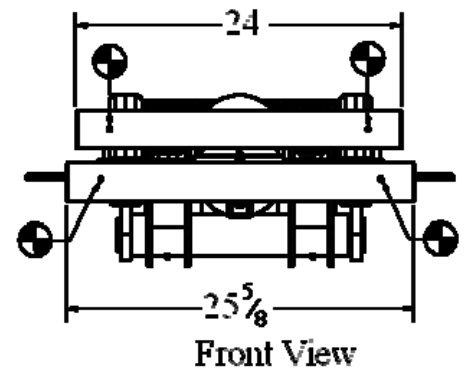
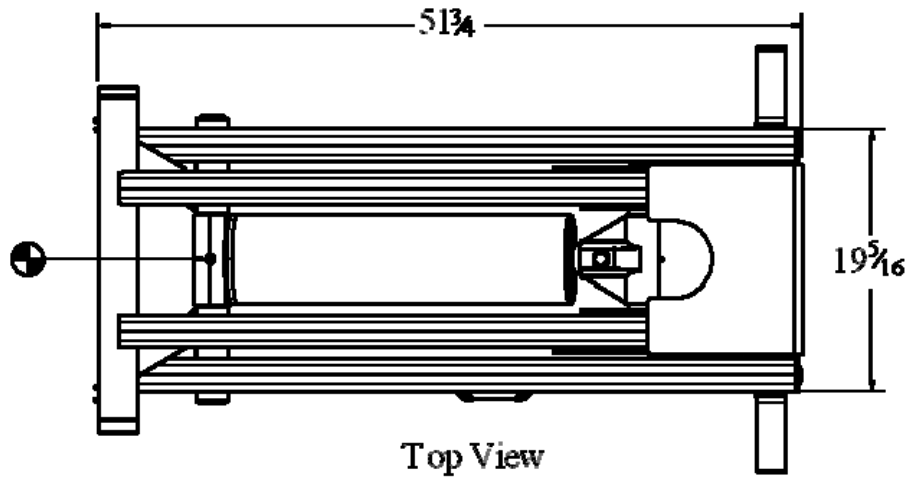

 Grease Fitting Locations

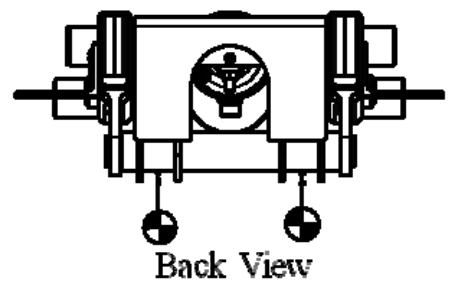
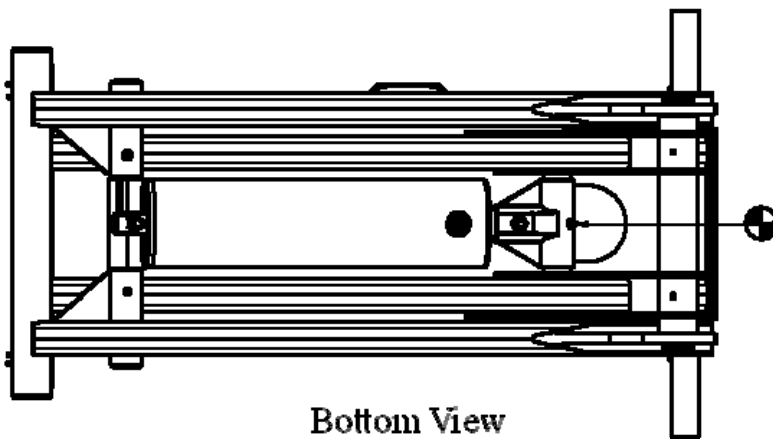

# CS620HDLP Parts List

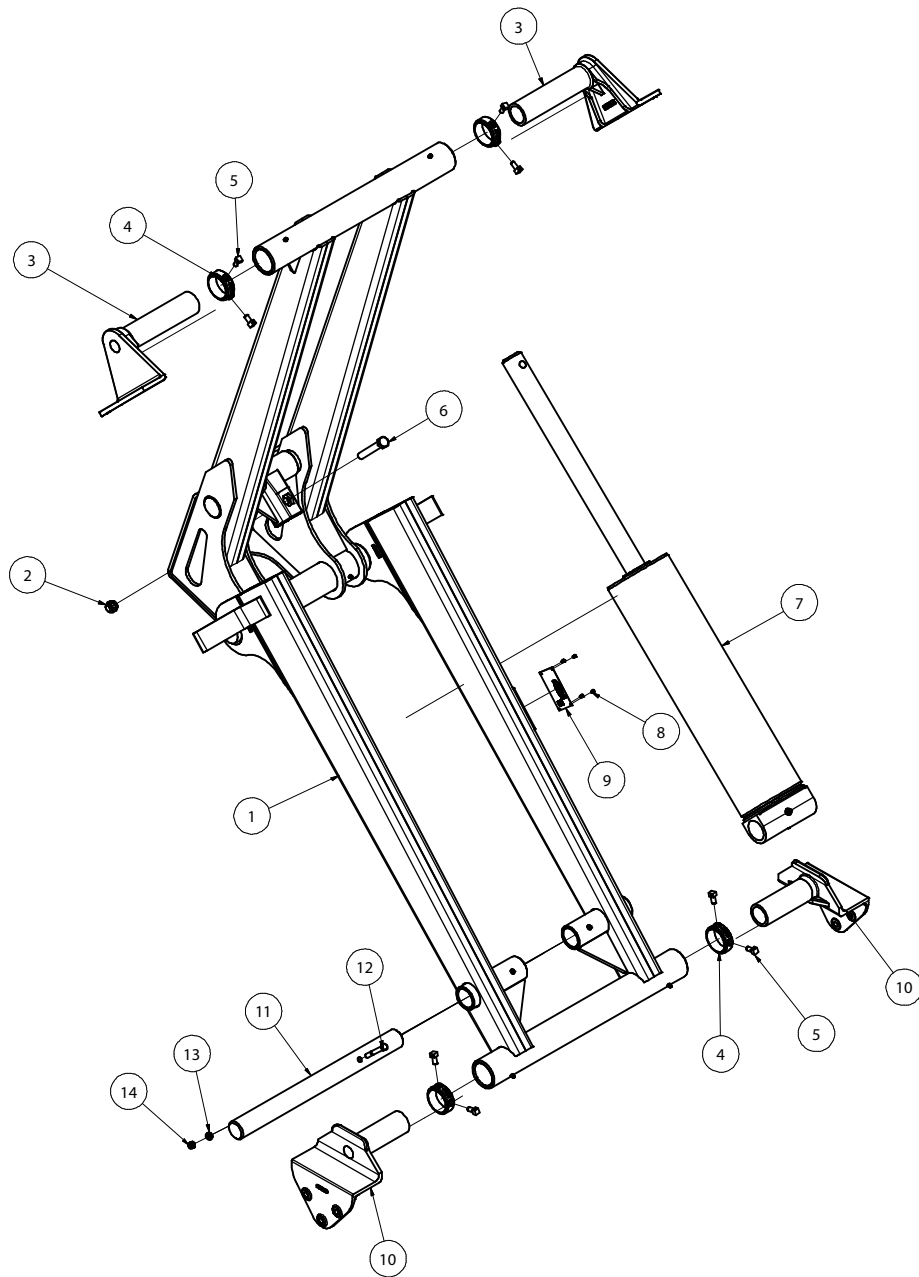

## PARTS LIST

ITEM	QTY	PART NUMBER	DESCRIPTION
1	1	W12489	SCISSOR HOIST WELDMENT, 620HD
2	1	116-7-A1	HEX NUT, 5/8" UNC
3	2	PC10626	2-1/4" UPPER LIFT ARM
4	4	PC12157	SET COLLAR FOR UPPER LIFT ARM 2-1/4"
5	8	P34	SET SCREW 3/8"-16 x 3/4" SQHD
6	1	102-617-L	Hex Cap Screw, 5/8 x 4, GR 9
7	1	A21328	ASSEMBLY, 620 DA CYLINDER
8	4	PAAP43	RIVET, 1/8" CHERRY POP
9	1	P10200	CHAMPION SERIAL PLATE
10	2	PC13285	LOWER LIFT ARM, 2 1/4"
11	1	PC12601	CYLINDER MOUNT SHAFT, 615HD/620HD/628
12	1	102-213-A1	HEX BOLT, 3/8 X 3 LG. GR 8
13	1	118-3-A1	Lock Washer, 3/8
14	1	116-3-A1	Hex Nut, 3/8 UNC

## CS6615LP Capacities

<b>CS6615LP Hoist Capacity (Tons)</b>			
<b>Body Length (Feet)</b>	<b>Overhang (Inches)</b>	<b>Dump Angle (Degrees)</b>	
		<b>"G" Dimension (Inches)</b>	
		<b>45 Deg.(82 Inches)</b>	<b>50 Deg. (74 Inches)</b>
12	0	15.40	13.90
	12	18.50	16.70
	18	20.60	18.60
	24	23.20	20.90
13	0	14.30	12.90
	12	16.80	15.20
	18	18.50	16.70
	24	20.60	18.60
14	0	13.20	11.90
	12	15.40	13.90
	18	16.80	15.20
	24	18.50	16.70
15	0	12.40	11.10
	12	14.30	12.90
	18	15.40	13.90
	24	16.80	15.20

# CS6615LP Dimensions

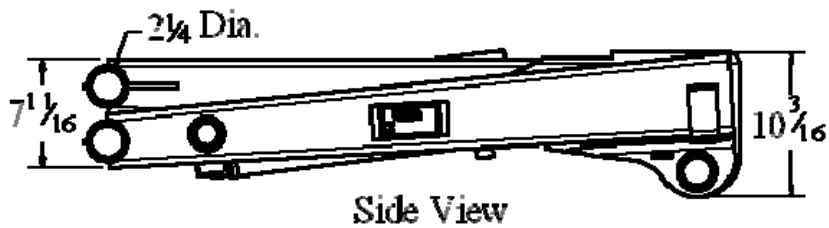
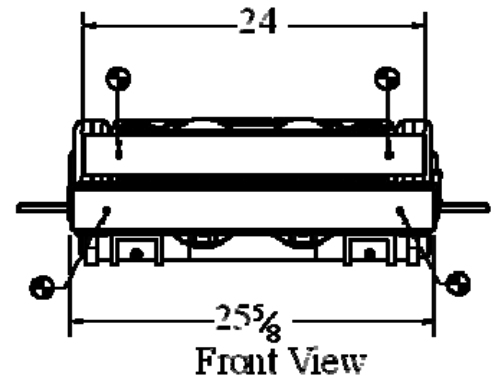
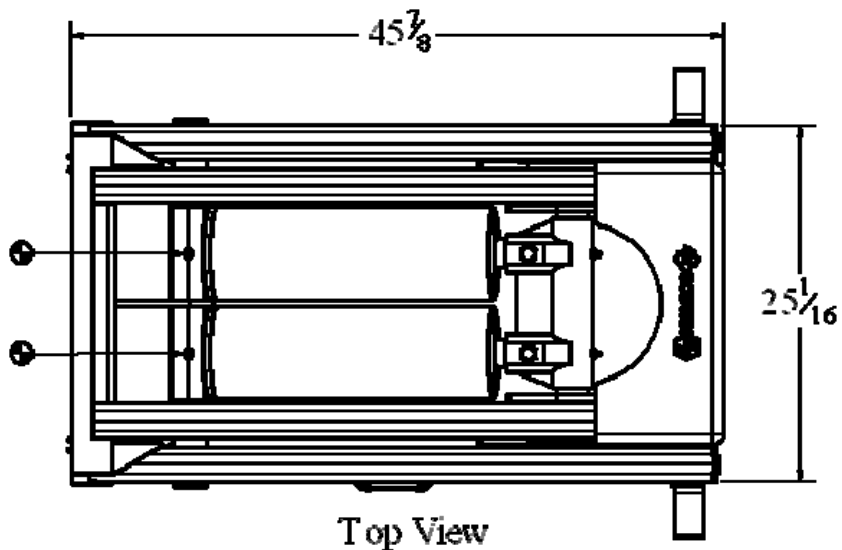

 Grease Fitting Locations

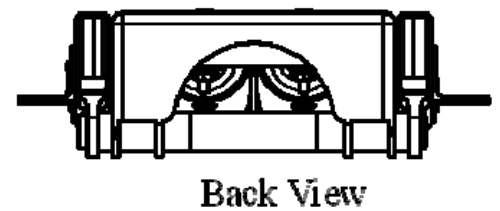
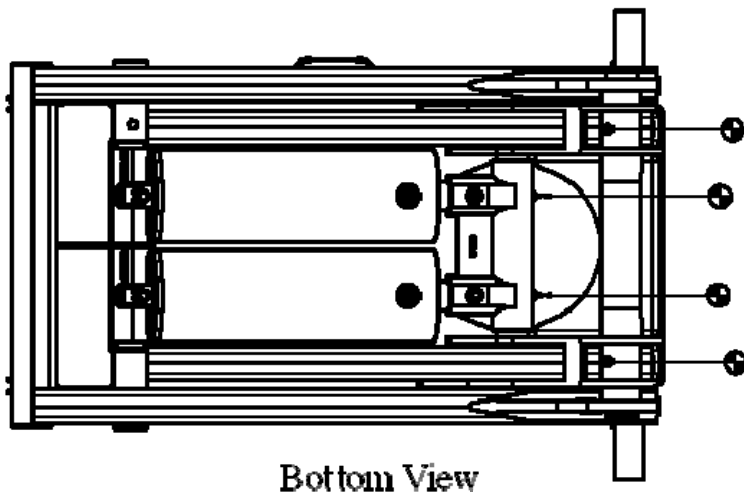

# CS6615LP Parts List

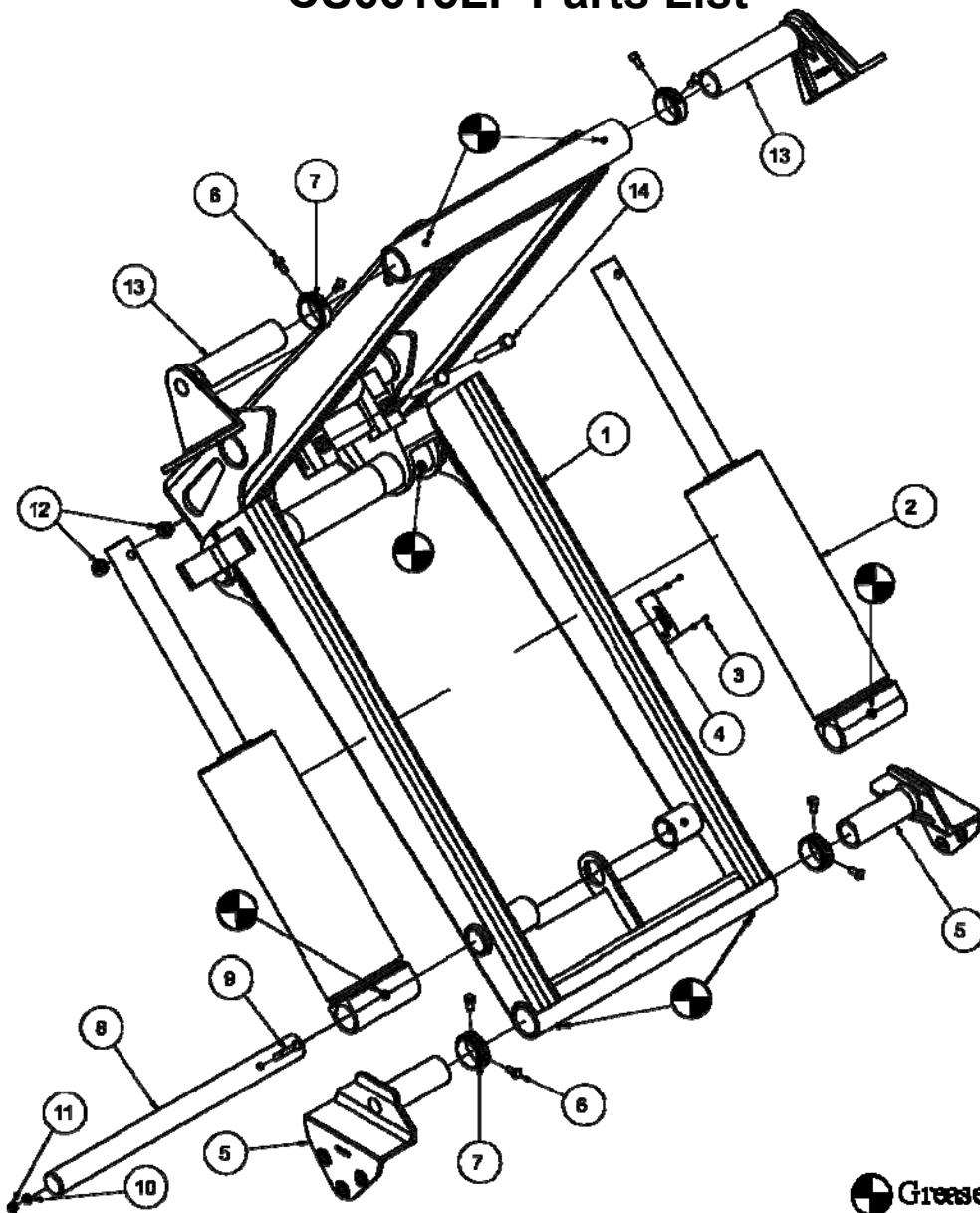

 Grease Fitting Locations

CS6615LP - Parts List (refer to engineering drawing A12552)

Item	Qty.	Part Number	Description
1	1	W12647	6615 Scissor Hoist Weldment (Fab. Lift Arms)
2	2	W21214	615 DA Cylinder Assembly
3	4	PAAP43	Rivet, 1/8" Cherry Pop
4	1	P10100	Serial Plate
5	2	PC13285	Lower Lift Arm, 2-1/4"
6	8	P34	Set Screw 3/8"-16 x 3/4" Square Head
7	4	PC12157	Set Collar for 2-1/4" Lift Arm
8	1	SM12058	Bottom Cylinder Shaft, 6615
9	1	102-213-A1	Hex Bolt, 3/8 x 3 LG. GR8
10	1	118-3-A1	Lock Washer, 3/8
11	1	116-3-A1	Hex Nut, 3/8 UNC
12	2	143-7	Lock Nut, Nylon, 5/8 UNC
13	2	PC10626	Upper lift Arm, 2-1/4"
14	2	102-617-L	Hex Cap Screw, 5/8 x 4, GR9



## CS6620LP Capacities

CS6620LP Hoist Capacity (Tons)			
Body Length (Feet)	Overhang (Inches)	Dump Angle (Degrees)	
		"G" Dimension (Inches)	
		45 Deg.(106.5 Inches)	50 Deg. (96.5 Inches)
14	0	18.10	16.40
	12	21.10	19.10
	18	23.00	20.80
	24	25.30	22.90
15	0	16.90	15.30
	12	19.50	17.60
	18	21.10	19.10
	24	23.00	20.80
16	0	15.80	14.30
	12	18.10	16.40
	18	19.50	17.60
	24	21.10	19.10

# CS6620LP Dimensions

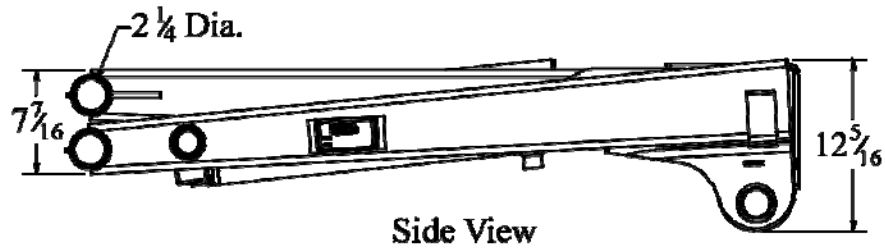
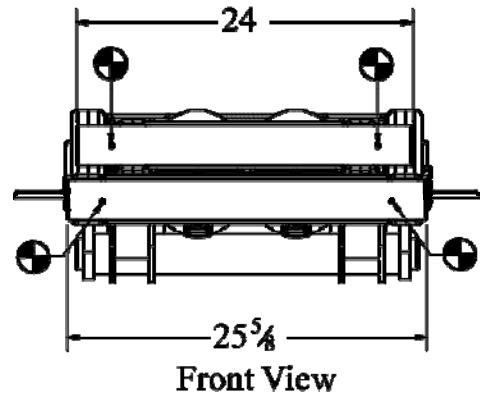
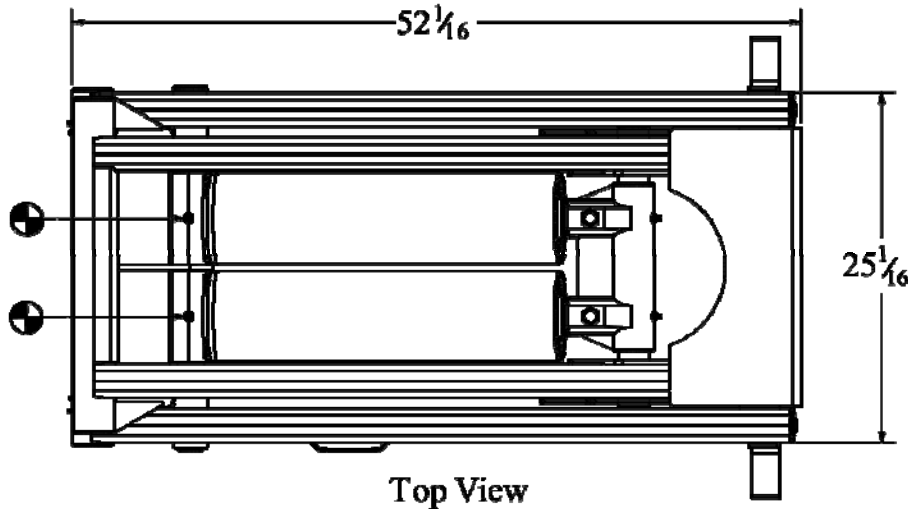

 Grease Fitting Locations

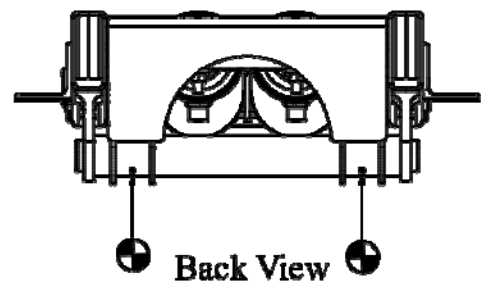
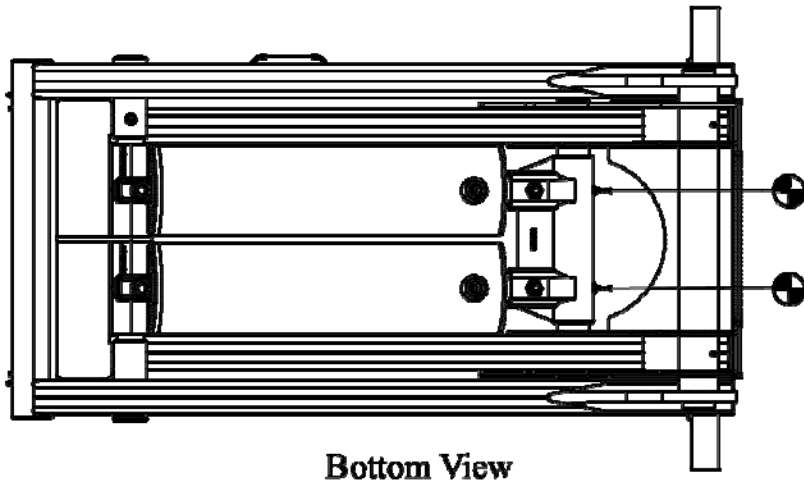

# CS6620LP Parts List

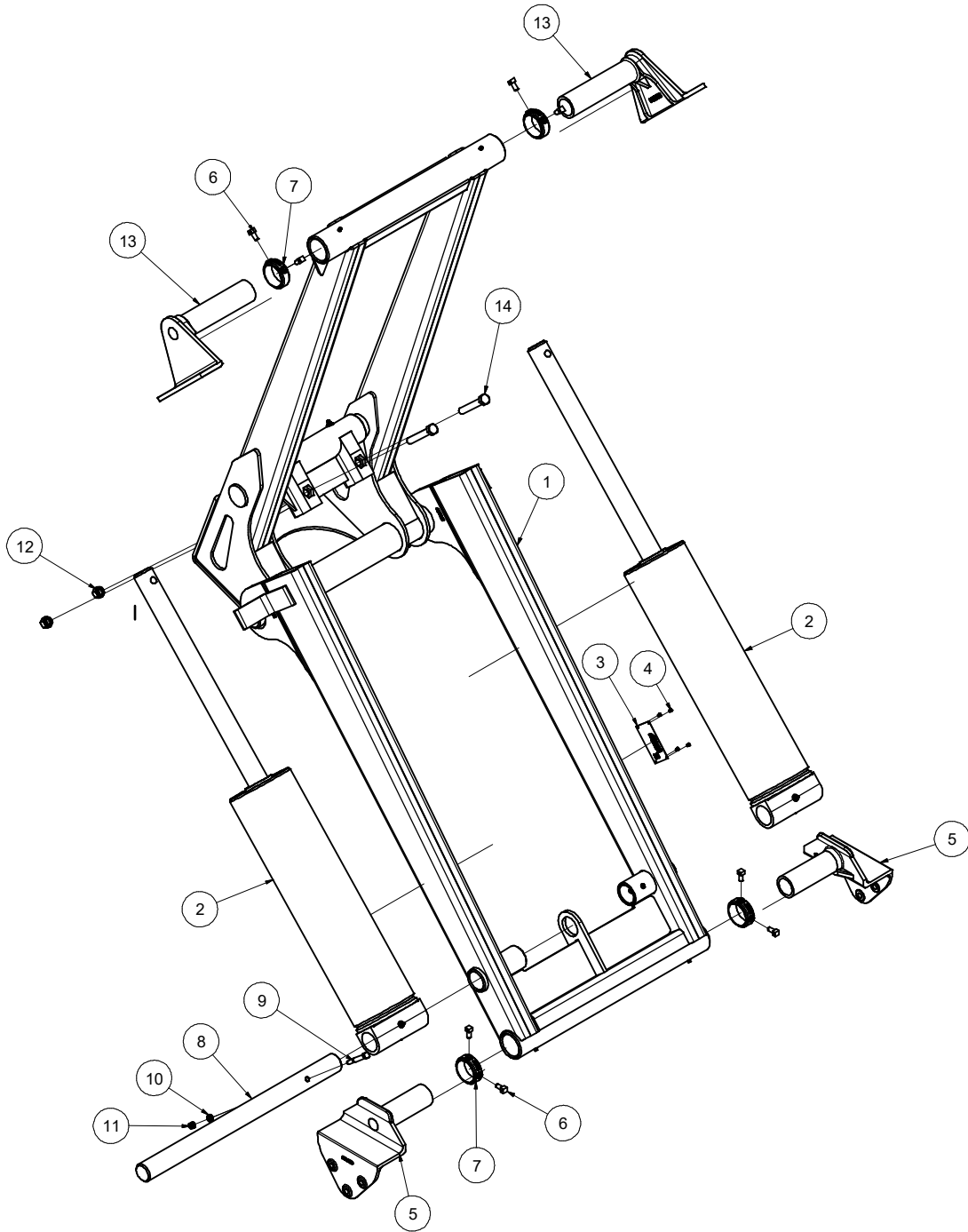

PARTS LIST			
ITEM	QTY	PART NUMBER	DESCRIPTION
1	1	W12640	WELDMENT, 6620 SCISSOR HOIST (FAB. SADDLE & LIFT ARMS)
2	2	A21387	WELDMENT, 620 DA CYLINDER & CAP WITH O-RING FITTINGS
3	1	P10200	CHAMPION SERIAL PLATE
4	4	PAAP43	RIVET, 1/8" CHERRY POP
5	2	PC13285	LOWER LIFT ARM, 2 1/4"
6	8	P34	SET SCREW 3/8"-16 x 3/4" SQHD
7	4	PC12157	SET COLLAR FOR 2-1/4" LIFT ARM
8	1	SM12058	CYLINDER MOUNT SHAFT, 6615/6620/5530/6630/5520T/6620T
9	1	102-213-A1	HEX BOLT, 3/8 X 3 LG. GR 8
10	1	118-3-A1	Lock Washer, 3/8
11	1	116-3-A1	Hex Nut, 3/8 UNC
12	2	116-7-A1	HEX NUT, 5/8" UNC
13	2	PC10626	2-1/4" UPPER LIFT ARM
14	2	102-617-L	Hex Cap Screw, 5/8 x 4, GR 9

## CS628LP Capacities

CS628LP Hoist Capacity (Tons)			
Body Length (Feet)	Overhang (Inches)	Dump Angle (Degrees)	
		"G" Dimension (Inches)	
		45 Deg.(132 Inches)	50 Deg. (119.5 Inches)
14	0	12.90	11.70
	12	15.10	13.60
	18	16.40	14.90
	24	18.10	16.40
15	0	12.00	10.90
	12	13.90	12.60
	18	15.10	13.60
	24	16.40	14.90
16	0	11.30	10.20
	12	12.90	11.70
	18	13.90	12.60
	24	15.10	13.60

# CS628LP Dimensions

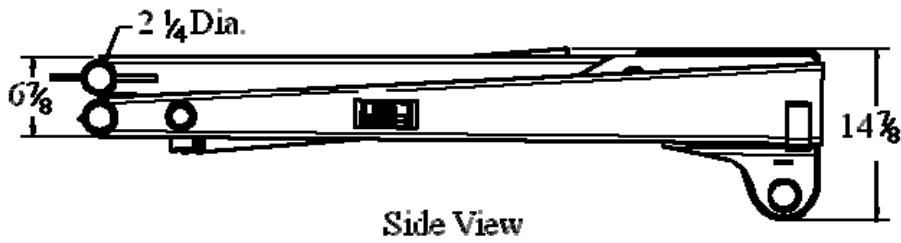
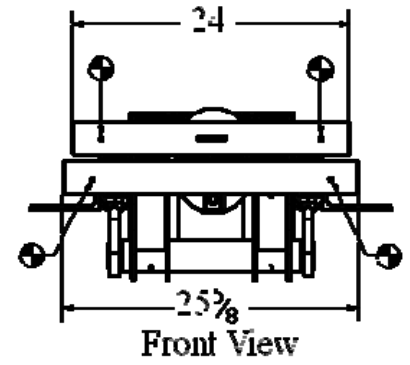
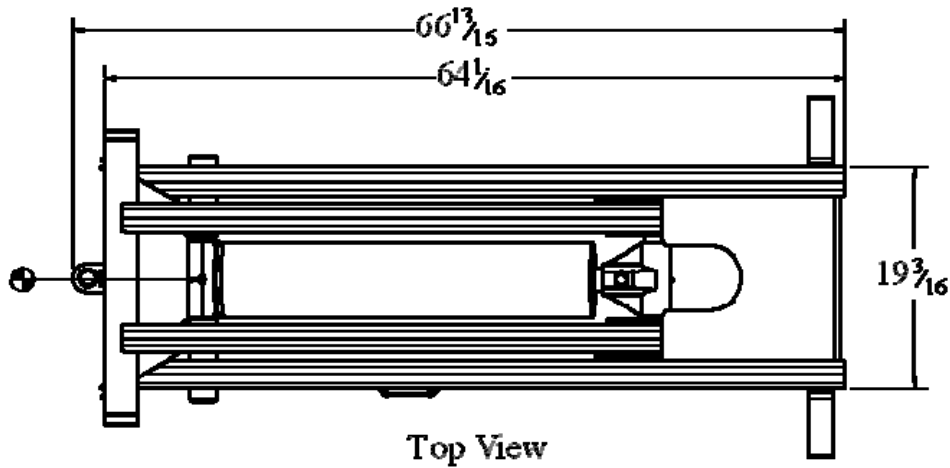

 Grease Fitting Locations

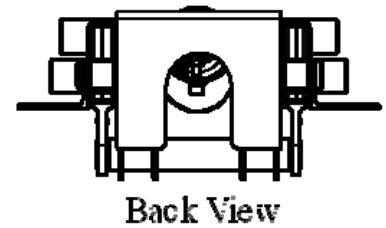
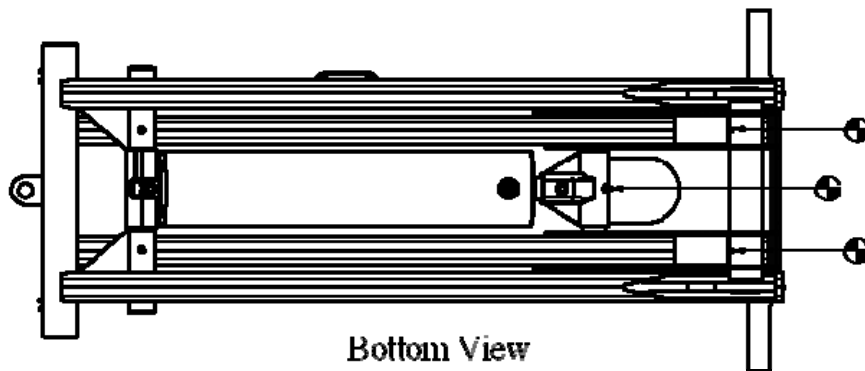

# CS628LP Parts List

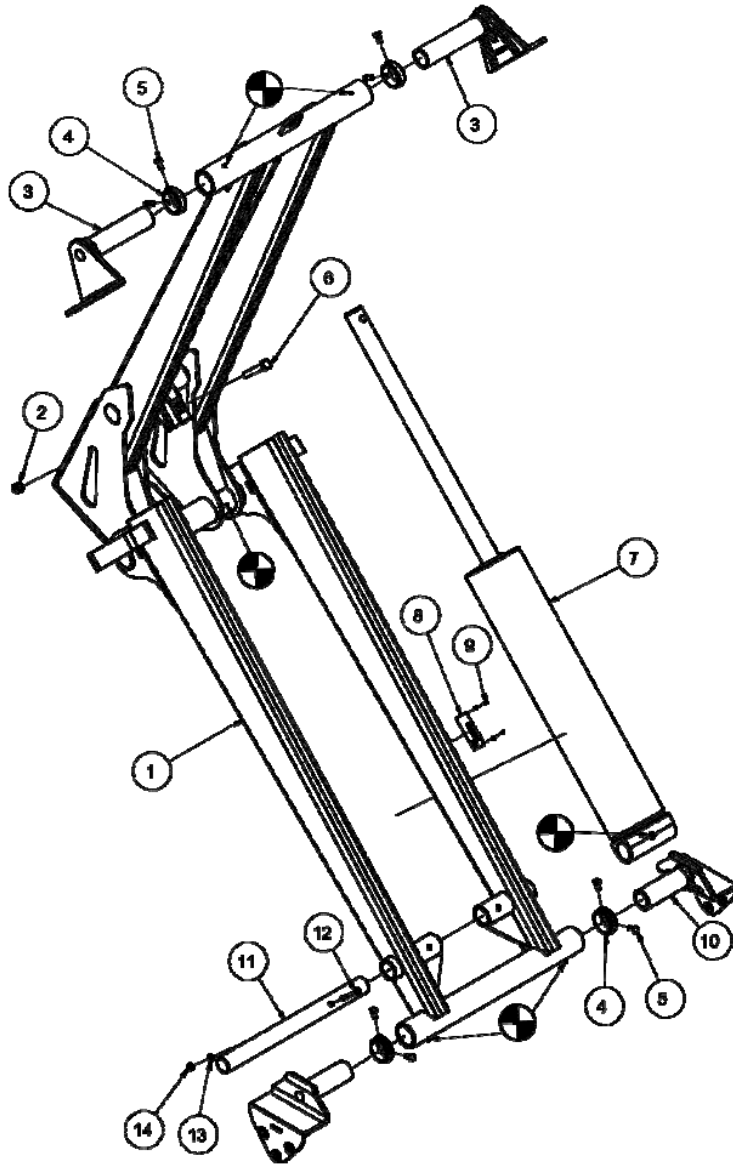

 Grease Fitting Locations

CS628LP - Parts List (refer to engineering drawing A12554)

Item	Qty.	Part Number	Description
1	1	W12508	628 Scissor Hoist Weldment (Fab Cross Tubes)
2	1	116-7-A1	Hex Nut, 5/8" UNC
3	2	PC10626	Upper lift Arm, 2-1/4"
4	4	PC12157	Set Collar for 2-1/4" Lift Arm
5	8	P34	Set Screw 3/8"-16 x 3/4" Square Head
6	1	102-617-L	Hex Cap Screw, 5/8 x 4, GR9
7	1	A21343	628 DA Cylinder Assembly
8	1	P10100	Serial Plate
9	4	PAAP43	Rivet, 1/8" Cherry Pop
10	2	PC13285	Lower Lift Arm, 2-1/4"
11	1	SM12048	Bottom Cylinder Shaft, 628
12	1	102-213-A1	Hex Bolt, 3/8 x 3 LG. GR8
13	1	118-3-A1	Lock Washer, 3/8
14	1	116-3-A1	Hex Nut, 3/8 UNC

## CS5530LP Capacities

CS5530LP Hoist Capacity (Tons)			
Body Length (Feet)	Overhang (Inches)	Dump Angle (Degrees)	
		"G" Dimension (Inches)	
		45 Deg.(138 Inches)	50 Deg. (125 Inches)
16	0	15.60	14.10
	12	17.80	16.10
	18	19.20	17.40
	24	20.80	18.80
17	0	14.70	13.30
	12	16.60	15.10
	18	17.80	16.10
	24	19.20	17.40
18	0	13.90	12.60
	12	15.60	14.10
	18	16.60	15.10
	24	17.80	16.10
19	0	13.10	11.90
	12	14.70	13.30
	18	15.60	14.10
	24	16.60	15.10
20	0	12.50	11.30
	12	13.90	12.60
	18	14.70	13.30
	24	15.60	14.10

# CS5530LP Dimensions

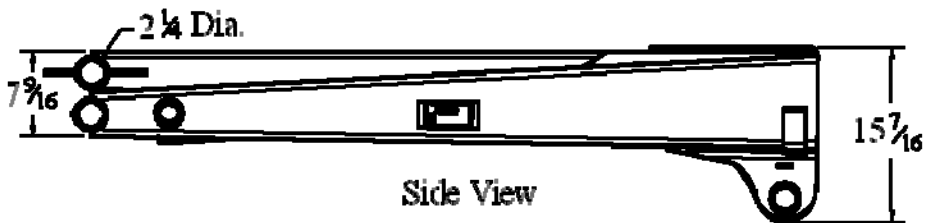
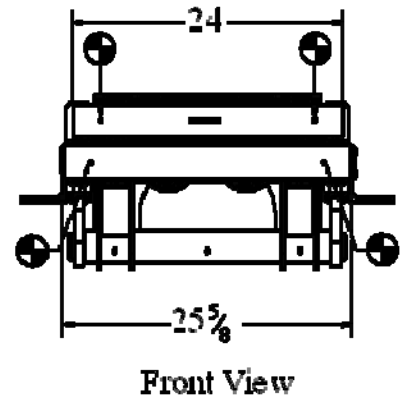
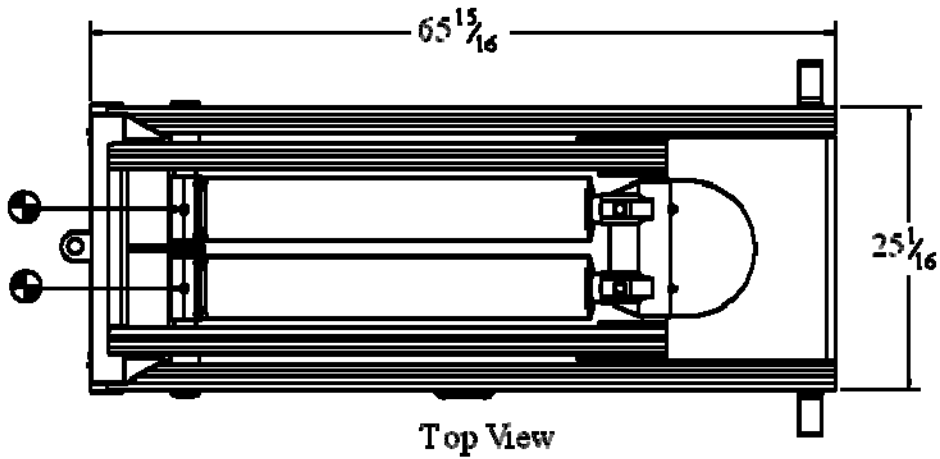

 Grease Fitting Locations

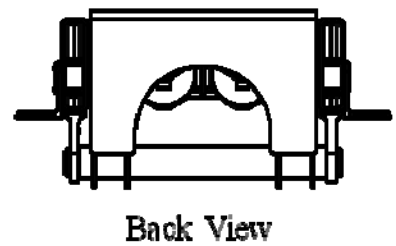
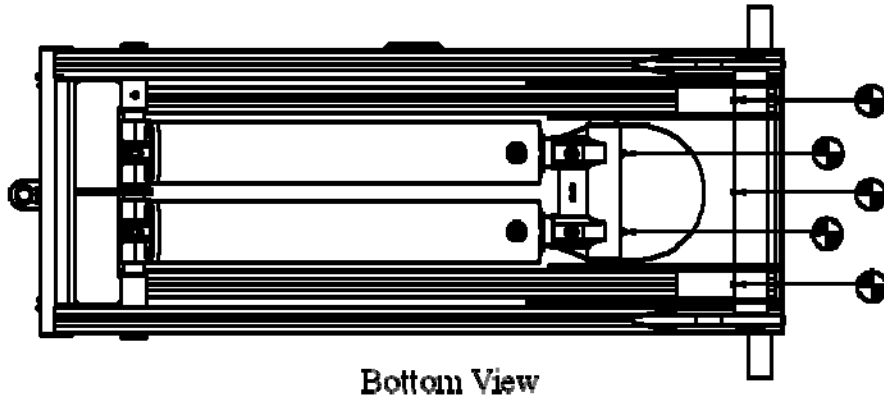



# CS5530LP Dimensions

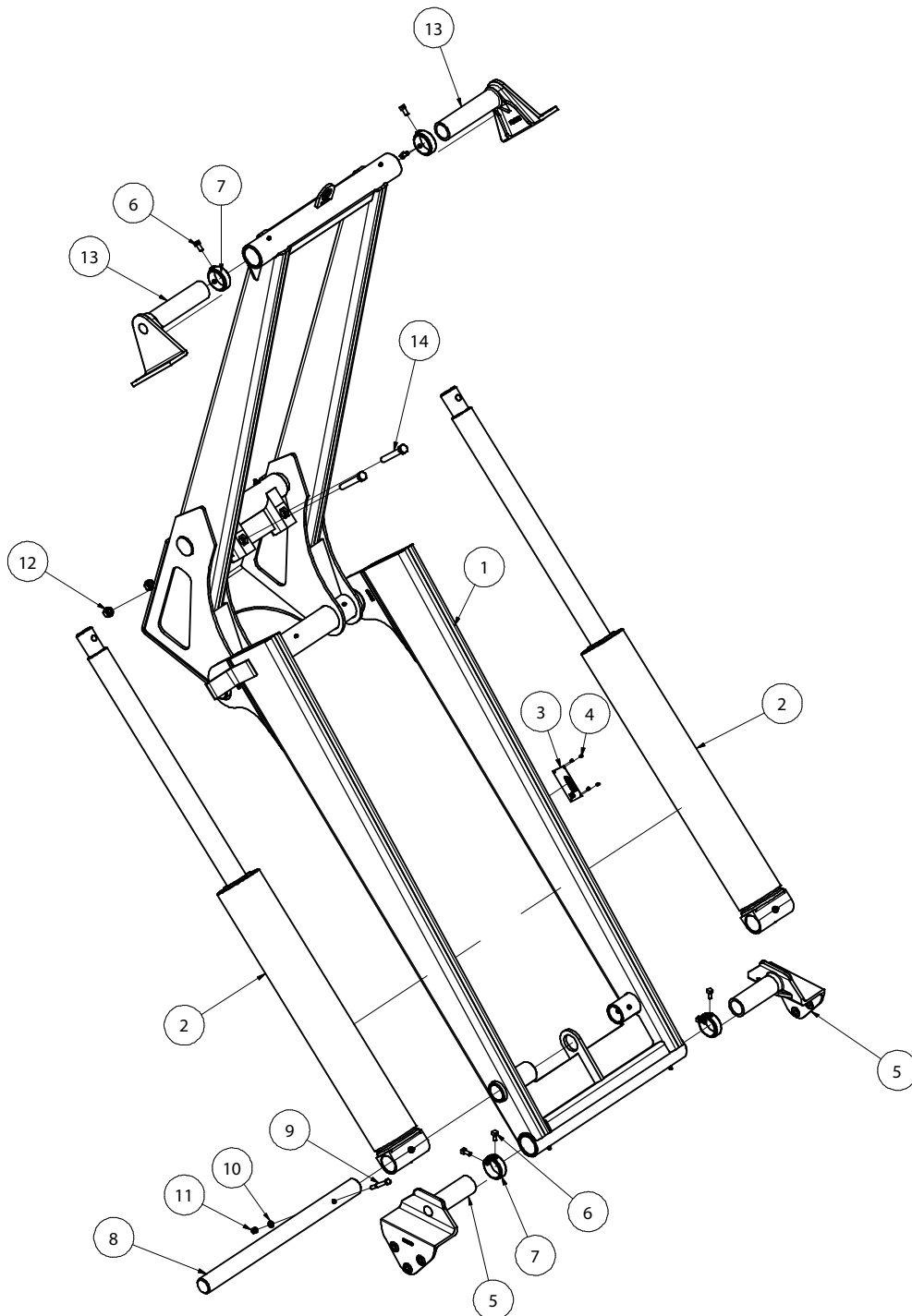

## PARTS LIST

ITEM	QTY	PART NUMBER	DESCRIPTION
1	1	W12535	WELDMENT, 5530/6630 SCISSOR ARM (FAB. SADDLE & LIFT ARMS)
2	2	A21409	ASSEMBLY, 530 DA CYLINDER WITH O-RING FITTINGS
3	1	P10200	CHAMPION SERIAL PLATE
4	4	PAAP43	RIVET, 1/8" CHERRY POP
5	2	PC13285	LOWER LIFT ARM, 2 1/4"
6	8	P34	SET SCREW 3/8"-16 x 3/4" SQHD
7	4	PC12157	SET COLLAR FOR 2-1/4" LIFT ARM
8	1	SM12058	CYLINDER MOUNT SHAFT, 6615/6620/5530/6630/5520T/6620T
9	1	102-213-A1	HEX BOLT, 3/8 X 3 LG. GR 8
10	1	118-3-A1	Lock Washer, 3/8
11	1	116-3-A1	Hex Nut, 3/8 UNC
12	2	116-7-A1	HEX NUT, 5/8" UNC
13	2	PC10626	2-1/4" UPPER LIFT ARM
14	2	102-617-L	Hex Cap Screw, 5/8 x 4, GR 9

## CS6630LP Capacities

CS6630LP Hoist Capacity (Tons)			
Body Length (Feet)	Overhang (Inches)	Dump Angle (Degrees)	
		"G" Dimension (Inches)	
		45 Deg.(138 Inches)	50 Deg. (125 Inches)
18	0	20.00	18.10
	12	22.40	20.30
	18	23.90	21.70
	24	25.70	23.00
19	0	18.90	17.10
	12	21.10	19.10
	18	22.40	20.30
	24	23.90	21.70
20	0	18.00	16.30
	12	20.00	18.10
	18	21.10	19.10
	24	22.40	20.30
21	0	17.10	15.50
	12	18.90	17.10
	18	20.10	18.10
	24	21.10	19.10
22	0	16.30	14.80
	12	18.00	16.30
	18	18.90	17.10
	24	20.00	18.10

# CS6630LP Dimensions

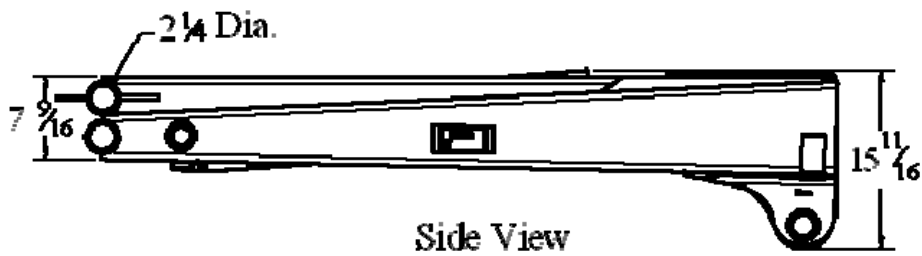
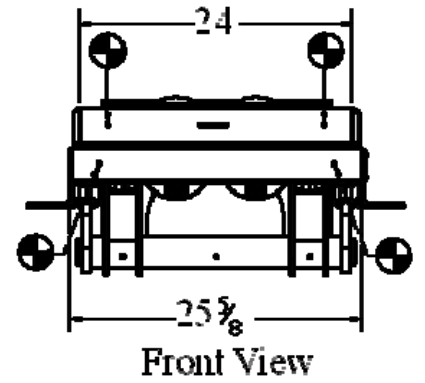
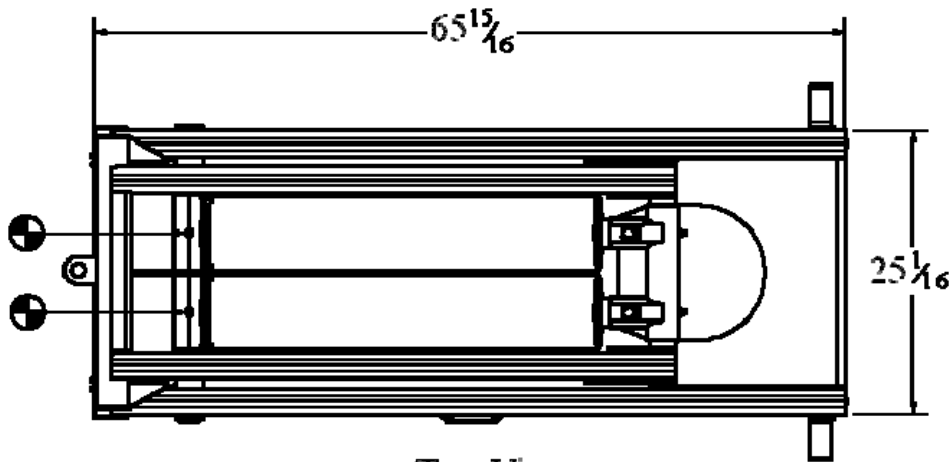

 Grease Fitting Locations

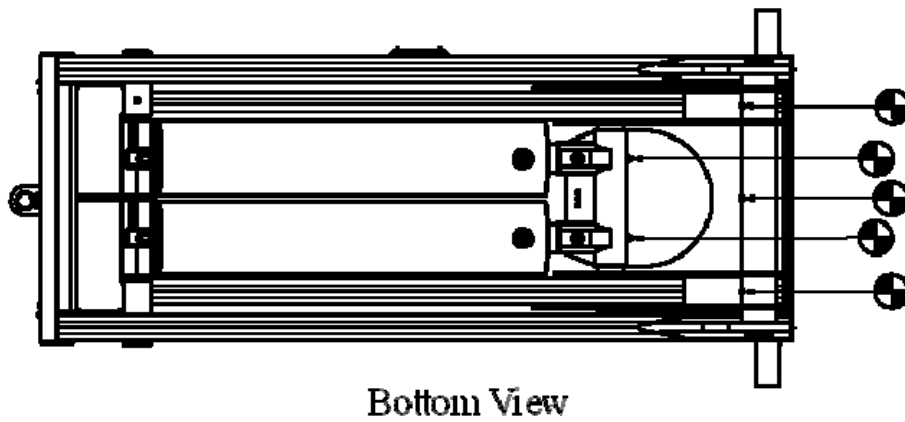

# CS6630LP Parts List

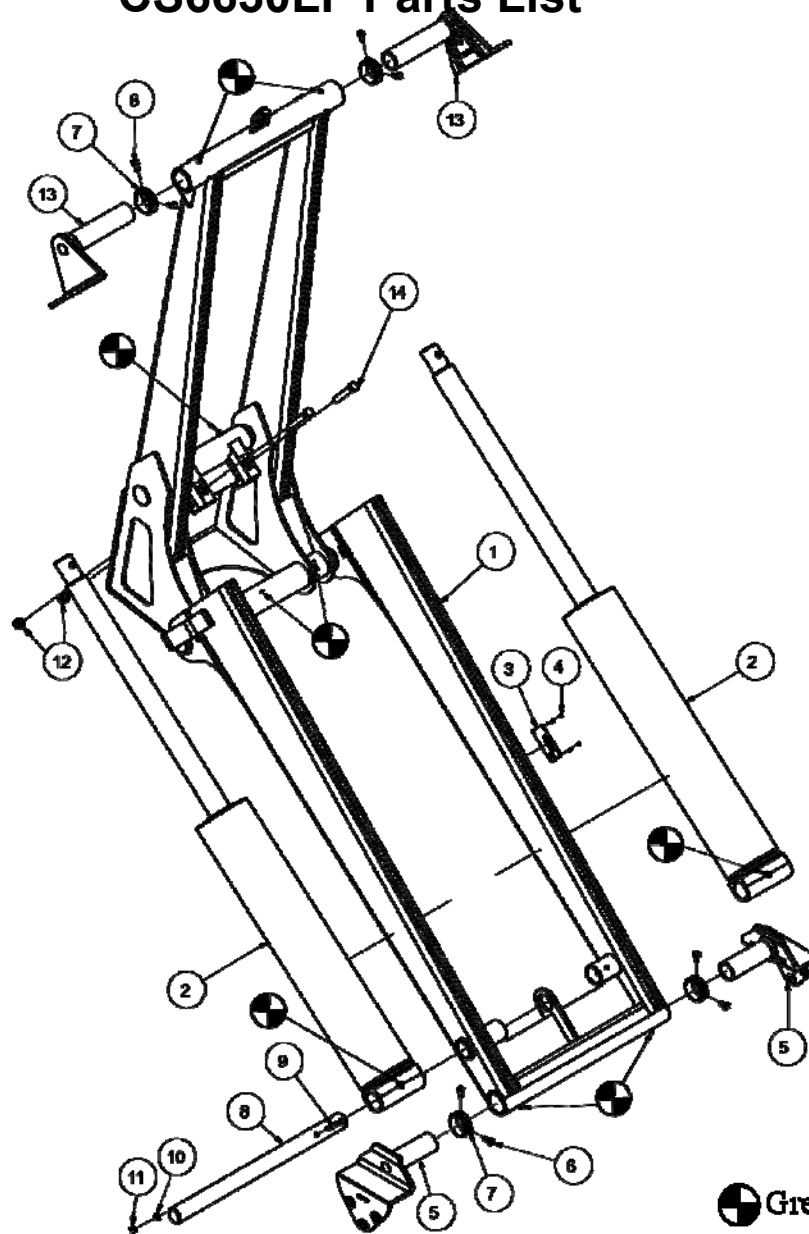

 Grease Fitting Locations

**GS6630LP - Parts List (refer to engineering drawing A12547)**

Item	Qty.	Part Number	Description
1	1	W12535	5530 Scissor Hoist Weldment (Fab Cross Tubes)
2	2	A21415	630 DA Cylinder Assembly with O-ring Fittings
3	1	P10200	Serial Plate
4	4	PAAP43	Rivet, 1/8" Cherry Pop
5	2	PC13285	Lower Lift Arm, 2-1/4"
6	8	P34	Set Screw 3/8"-16 x 3/8" Square Head
7	4	PC12157	Set Collar for 2-1/4" Lift Arm
8	1	SM12058	Bottom Cylinder Shaft
9	1	102-213-A1	Hex Bolt, 3/8" x 3" LG. GR8
10	1	118-3-A1	Lock Washer, 3/8"
11	1	116-3-A1	Hex Nut, 3/8" UNC
12	2	116-7-A1	Hex Nut, 5/8" UNC
13	2	PC10626	Upper lift Arm, 2-1/4"
14	2	102-617-L	Hex Cap Screw, 5/8" x 4", GR9

# Rear Hinge Assembly

PARTS LIST			
ITEM	QTY	PART NUMBER	DESCRIPTION
1	2	PC10355C	2" REAR HINGE BLOCK, CASTING LG. CONTRACTOR BODY
2	1	SM20065	REAR HINGE SHAFT
3	2	125-259	COTTER PIN, 1/4 x 2 1/2
4	2	PC10336	BRACKET, CASTING FRAME ATTACH, 10" REAR HINGE
5	4	P800	1/8" PIPE THREAD GREASE FITTING

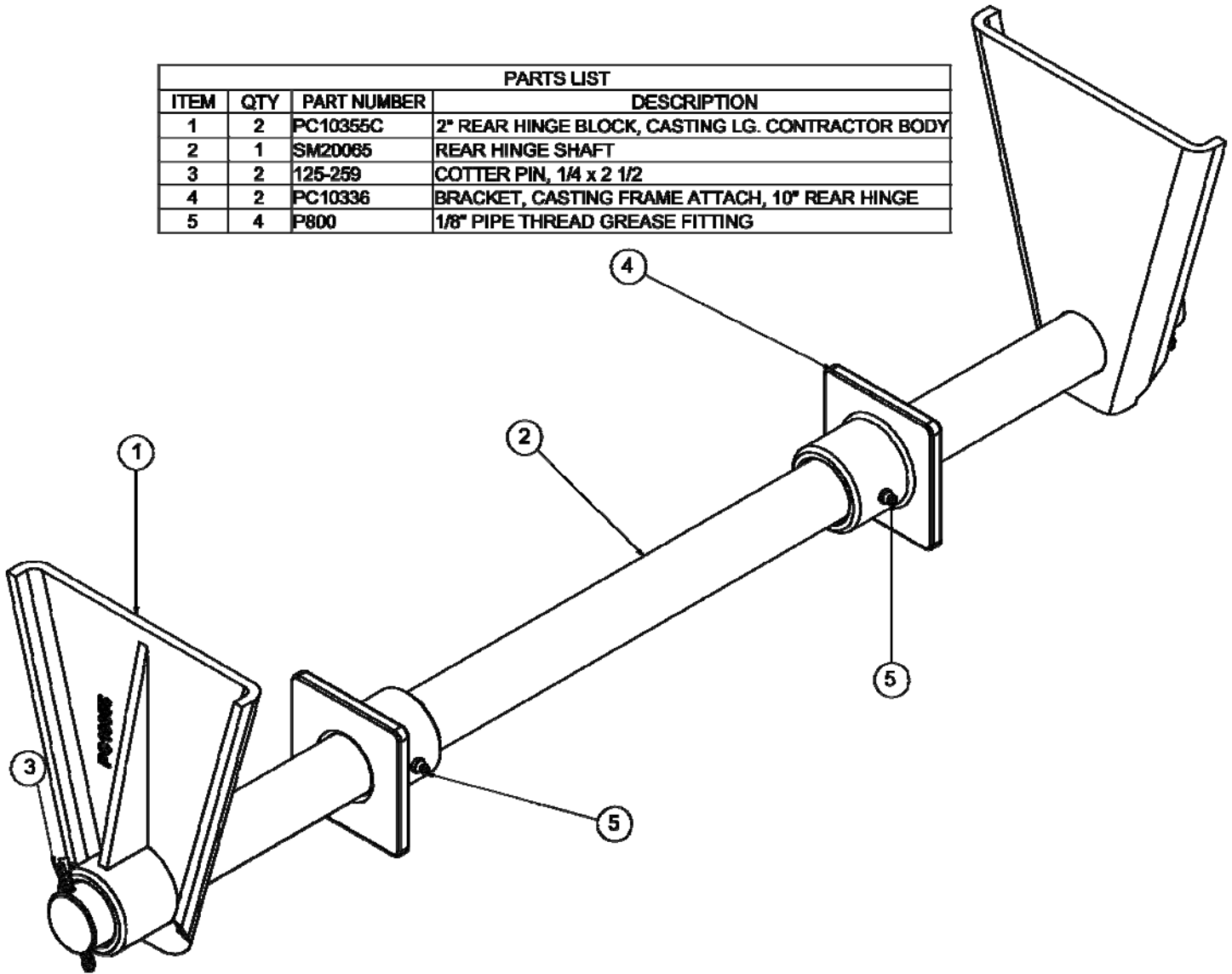

## WARRANTY

Champion Hoist and Equipment warrants these products for a period of 36 months from the date of sale to the customer.

This warranty provides that the equipment shall be free of defective materials and workmanship, or we will replace or repair at our factory, any part that our inspection shows to be defective.

The hydraulic valve, pump, motor, hoses, and other purchased products are not manufactured or warranted by Champion Hoist and Equipment and are therefore covered by the warranties of the manufacturer of these products.

Any part shipped to the factory shall be prepaid, and will be returned collect. Champion Hoist and Equipment does not assume responsibility for shipping, labor or travel expenses.

We reserve the right to make improvements to any of our product without notice or obligation regarding model previously sold.

